

(別紙 1) 業務フロー

業務フロー一覧（79フロー）

| 区分                  | 大分類                                       | 小分類                    | 頁番号 |
|---------------------|---|------------------------|-----|
| 1 障害者福祉             | 02 身体障害者手帳                                | 01 新規交付申請              | 1   |
|                     |   | 02 再交付申請（紛失・破損）        |     |
|                     |   | 03 再交付申請（等級変更・障害部位追加等） |     |
|                     |   | 04 記載事項変更（氏名・住所等）届出    |     |
|                     |   | 05 転出                  |     |
|                     |   | 06 返還届・死亡              |     |
|                     |   | 07 再認定                 |     |
|                     | 03 療育手帳                                   | 01 新規交付申請              | 11  |
|                     |   | 02 再交付申請（紛失・破損）        |     |
|                     |   | 03 記載事項変更（氏名・住所等）届出    |     |
|                     |   | 04 再交付申請（程度変更）         |     |
|                     |   | 05 転出                  |     |
| 06 返還届・死亡           |   |                        |     |
| 07 再判定              |   |                        |     |
| 04 精神障害者保健福祉手帳      | 01 新規交付申請                                 | 21                     |     |
|                     | 02 再交付申請（紛失・破損）                           |                        |     |
|                     | 03 記載事項変更（氏名・住所等）届出                       |                        |     |
|                     | 04 変更申請（等級変更）                             |                        |     |
|                     | 05 返還届出・死亡・転出                             |                        |     |
|                     | 06 更新申請                                   |                        |     |
| 05 国制度手当            | 01 認定請求～認定                                | 30                     |     |
|                     | 02 手当支払                                   |                        |     |
|                     | 03 変更届（氏名・住所・口座等の変更）                      |                        |     |
|                     | 04 資格喪失                                   |                        |     |
|                     | 05 現況届                                    |                        |     |
|                     | 06 有期認定                                   |                        |     |
|                     | 07 一時差止                                   |                        |     |
|                     | 08 年齢到達                                   |                        |     |
| 06 障害福祉サービス等（受給者管理） | 01 介護給付費支給申請                              | 42                     |     |
|                     | 02 訓練等給付費支給申請                             |                        |     |
|                     | 03 地域相談支援給付費支給申請                          |                        |     |
|                     | 04 児童通所支援給付費支給申請                          |                        |     |
|                     | 05 計画相談・障害児相談支援給付費支給申請                    |                        |     |
|                     | 06 モニタリング管理（実施の報告・期間等の変更）                 |                        |     |
|                     | 07 支給決定                                   |                        |     |
|                     | 08 変更申請（支給量・障害支援区分変更・負担上限額変更）             |                        |     |
|                     | 09 記載事項変更（氏名・住所・計画相談事業所変更等）               |                        |     |
|                     | 10 受給者証の再交付                               |                        |     |
|                     | 11 更新申請勧奨                                 |                        |     |
|                     | 12 年齢到達                                   |                        |     |
|                     | 13 支給決定取消                                 |                        |     |
|                     | 14 国保連受給者異動                               |                        |     |
|                     | 15 認定調査                                   |                        |     |
|                     | 16 医師意見書                                  |                        |     |
|                     | 17 一次判定／二次判定（審査会）                         |                        |     |
| 07 障害福祉サービス等（給付管理）  | 01 市町村審査・支払                               | 64                     |     |
|                     | 02 高額障害福祉サービス費                            |                        |     |
|                     | 03 過誤申立                                   |                        |     |
| 08 自立支援医療（更生医療）     | 01 新規申請                                   | 72                     |     |
|                     | 02 記載事項変更（氏名・住所・保険等）                      |                        |     |
|                     | 03 変更申請（医療の具体的方針の変更・再認定・医療機関追加変更・負担上限額変更） |                        |     |
|                     | 04 再交付申請（紛失・破損）                           |                        |     |
|                     | 05 公費負担医療管理                               |                        |     |
|                     | 06 更新申請                                   |                        |     |
|                     | 07 返還（死亡等）                                |                        |     |
| 09 自立支援医療（育成医療）     | 01 新規申請                                   | 82                     |     |
|                     | 02 記載事項変更（氏名・住所・保険等）                      |                        |     |
|                     | 03 変更申請（医療の具体的方針の変更・再認定・医療機関追加変更・負担上限額変更） |                        |     |
|                     | 04 再交付申請（紛失・破損）                           |                        |     |
|                     | 05 公費負担医療管理                               |                        |     |
|                     | 06 更新申請                                   |                        |     |
|                     | 07 返還（死亡等）                                |                        |     |
| 10 自立支援医療（精神通院医療）   | 01 新規申請                                   | 91                     |     |
|                     | 02 記載事項変更（氏名・住所・保険等）                      |                        |     |
|                     | 03 変更申請（医療機関変更・負担上限額変更）                   |                        |     |
|                     | 04 再交付申請（紛失・破損）                           |                        |     |
|                     | 05 更新申請                                   |                        |     |
|                     | 06 返還（死亡等）                                |                        |     |
| 11 補装具              | 01 支給決定                                   | 99                     |     |
|                     | 02 補装具費支給                                 |                        |     |
| 12 特別児童扶養手当         | 01 認定請求～認定                                | 102                    |     |
|                     | 02 資格喪失                                   |                        |     |
|                     | 03 所得状況届                                  |                        |     |
|                     | 04 有期認定                                   |                        |     |
|                     | 05 変更届（氏名・住所・口座・再交付申請・証書亡失届等）             |                        |     |
|                     | 06 額改定請求                                  |                        |     |
|                     | 07 年齢到達                                   |                        |     |
|                     | 08 一時差止                                   |                        |     |
|                     | 09 手当支払                                   |                        |     |

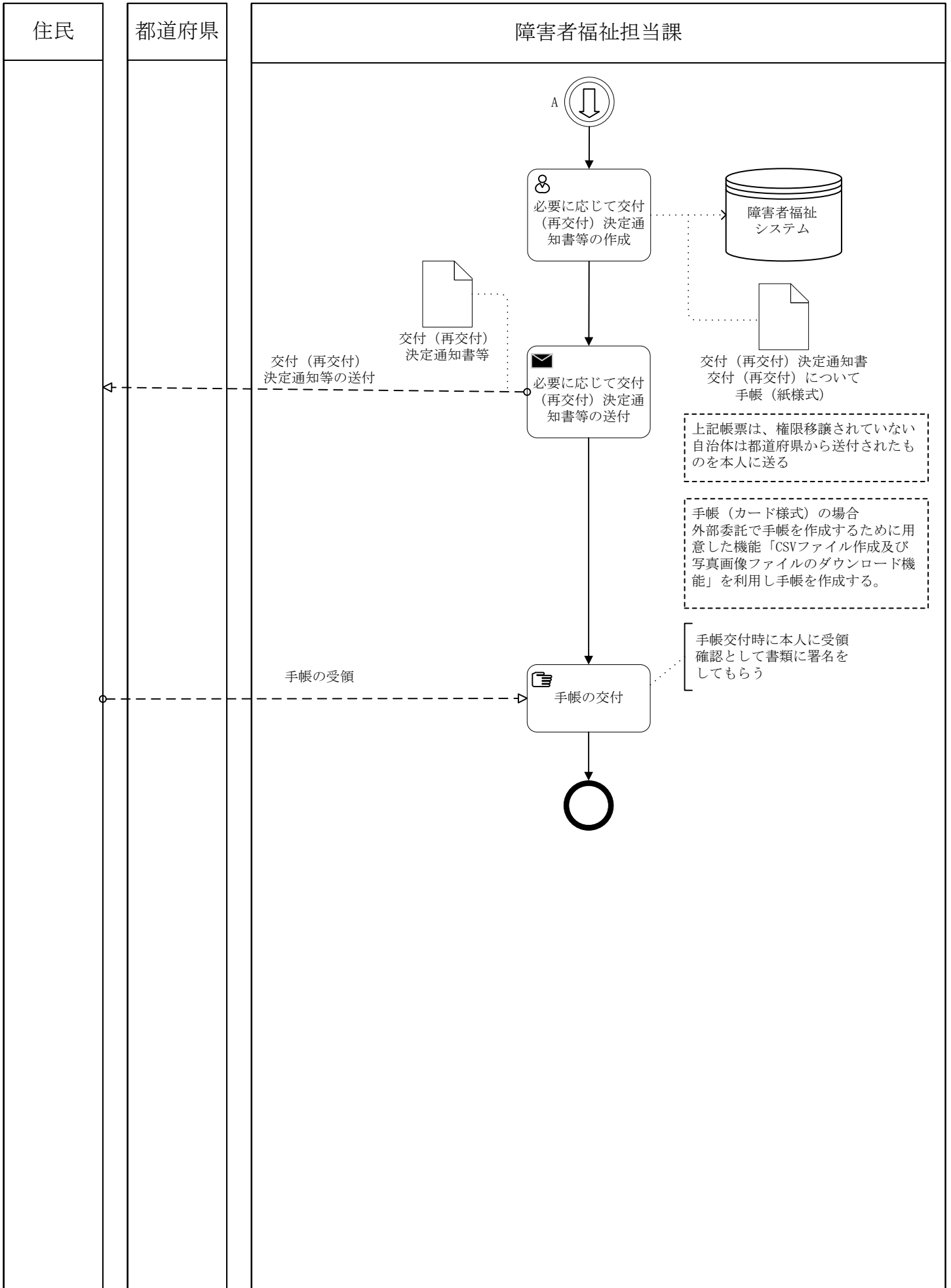



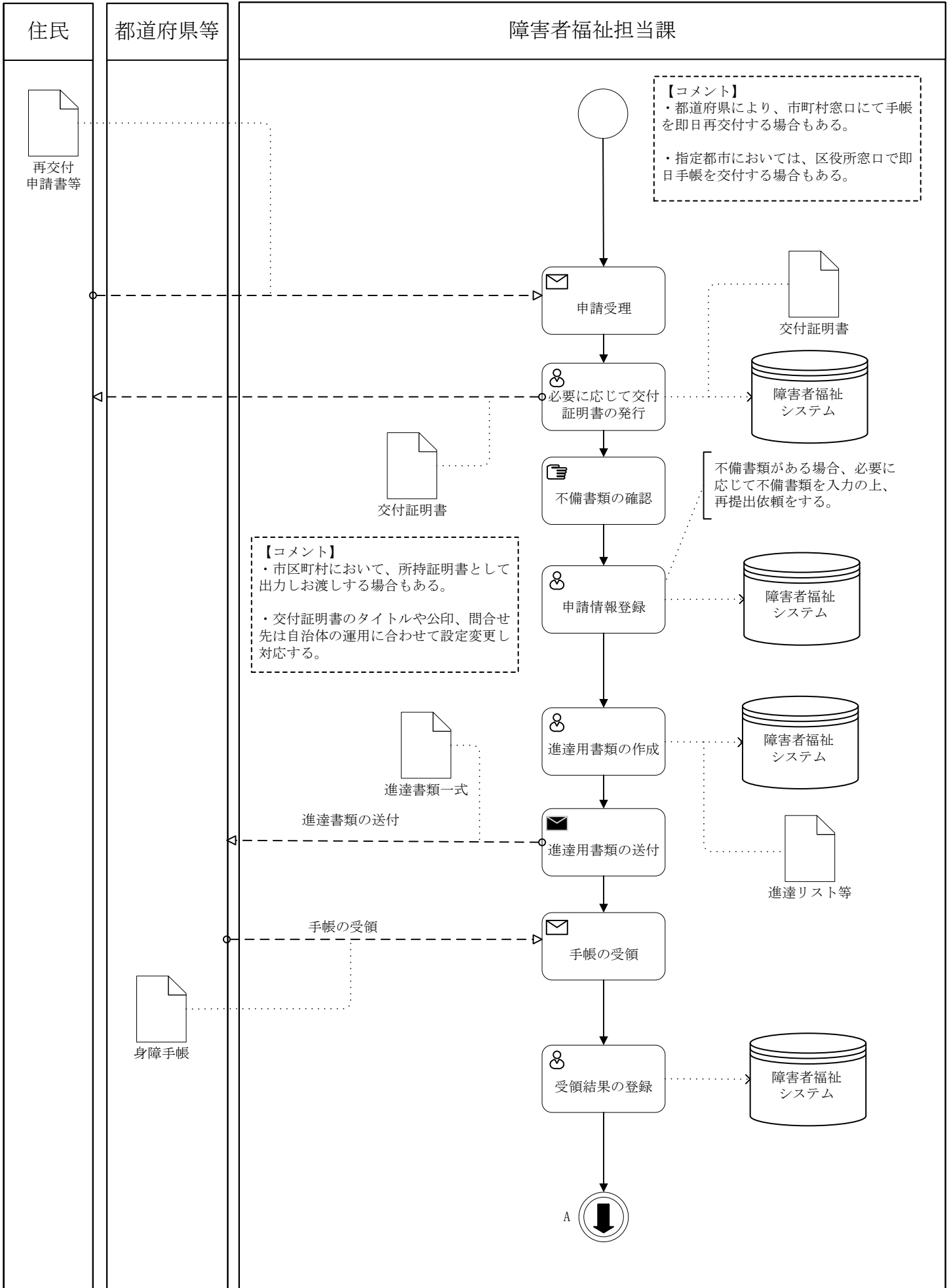

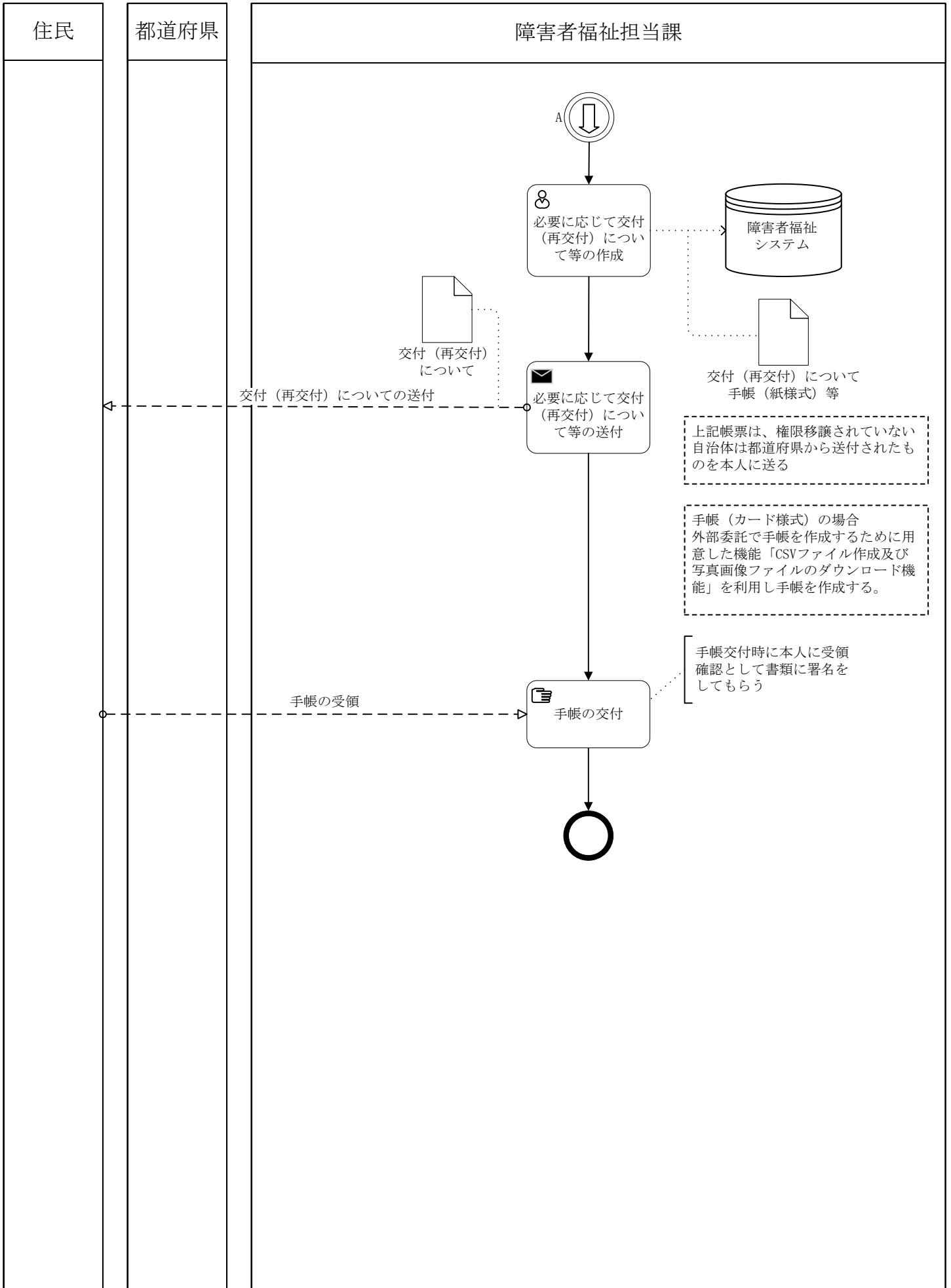

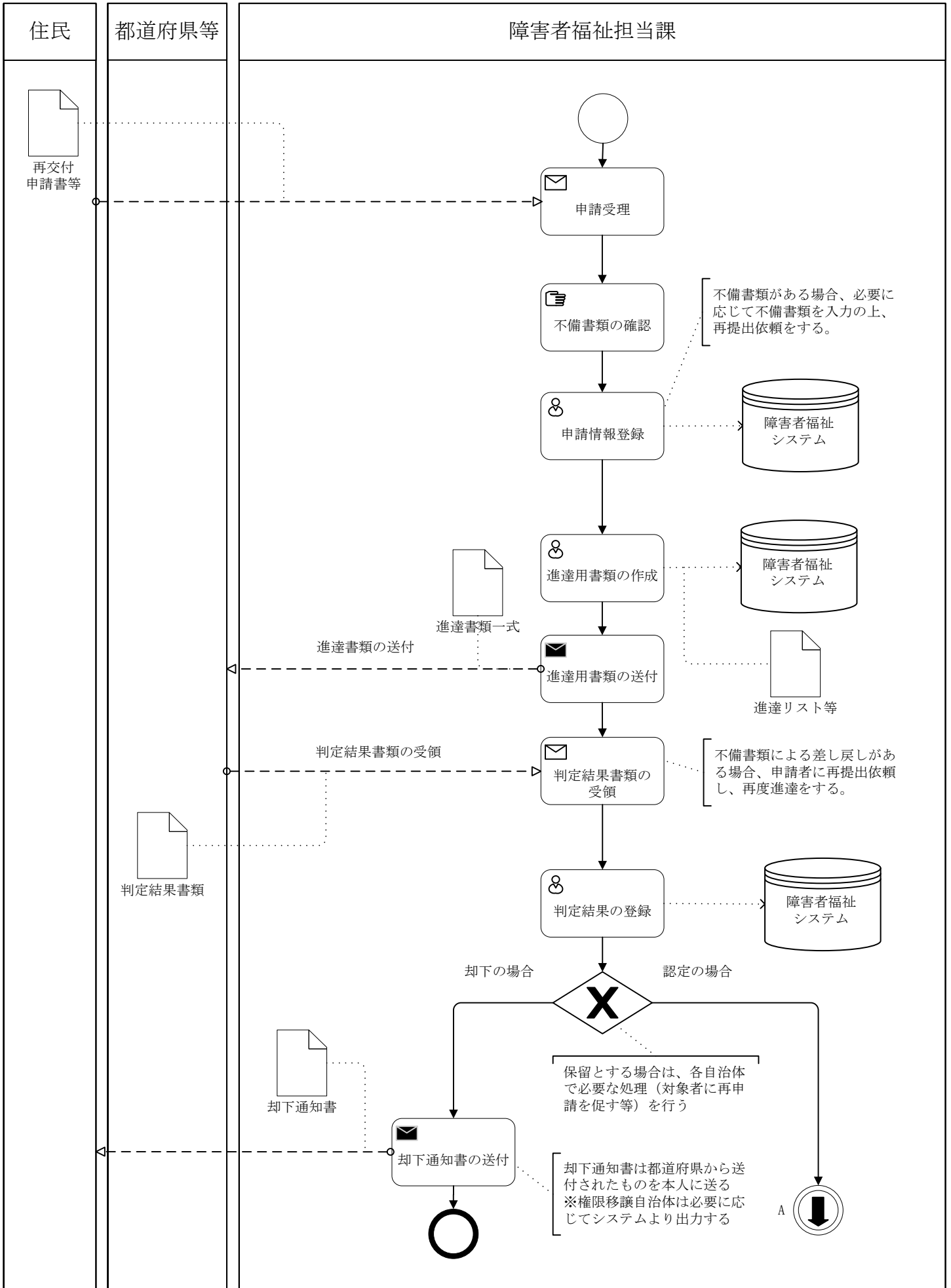

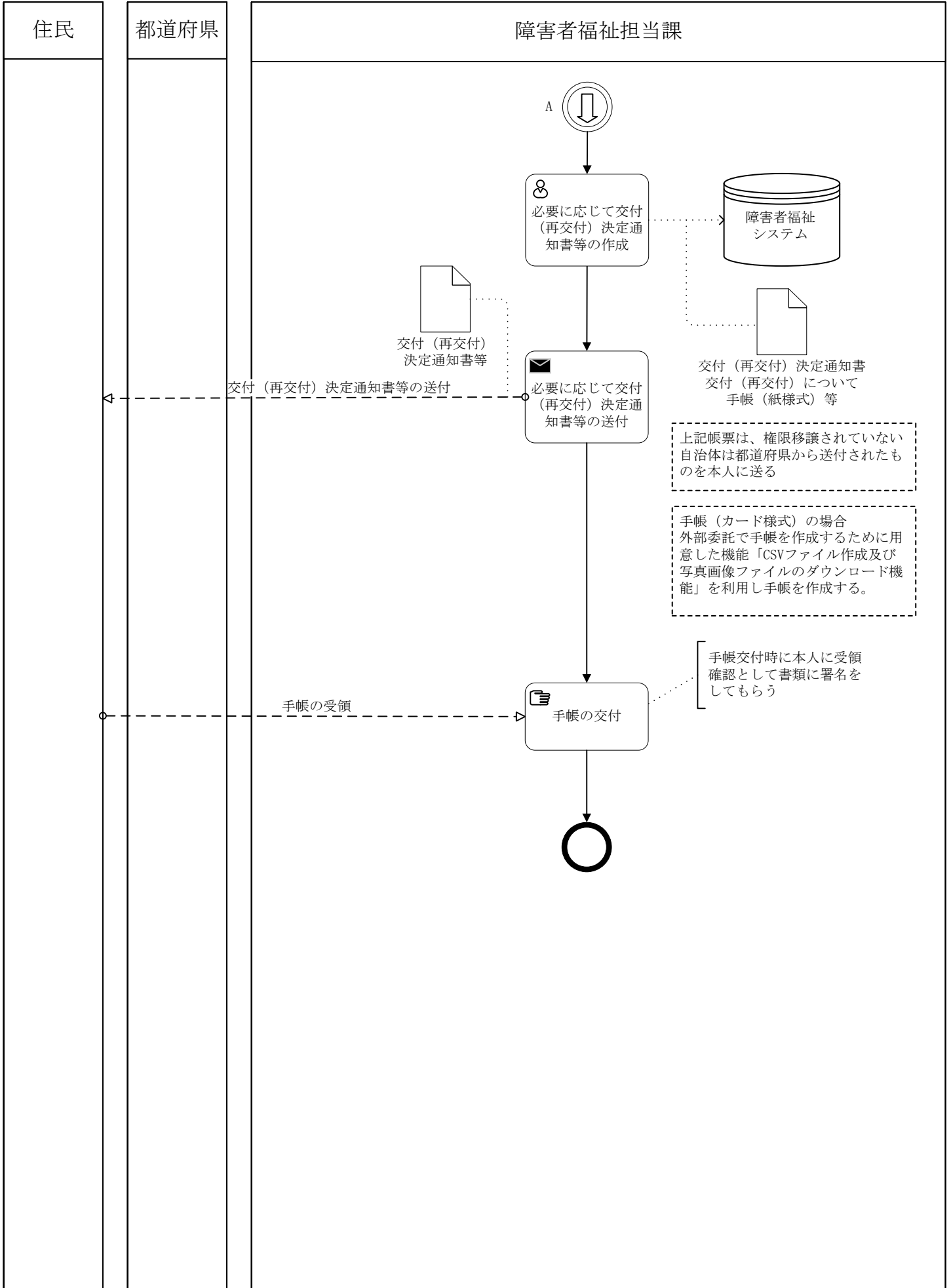



|    |         |     |            |     |                          |
|----|---------|-----|------------|-----|--------------------------|
| 区分 | 1 障害者福祉 | 大分類 | 02 身体障害者手帳 | 小分類 | 04 記載事項変更<br>(氏名・住所等) 届出 |
|----|---------|-----|------------|-----|--------------------------|

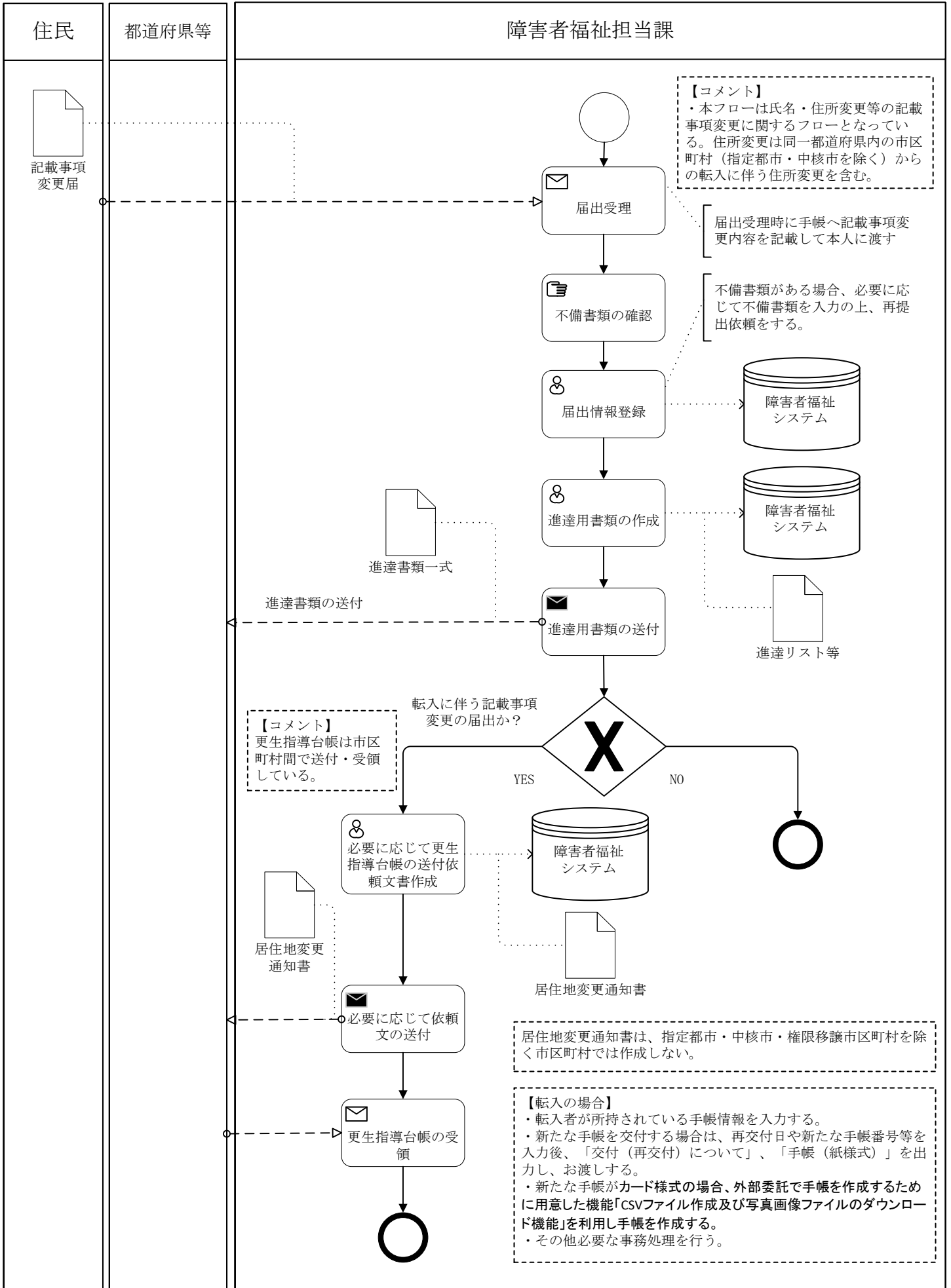

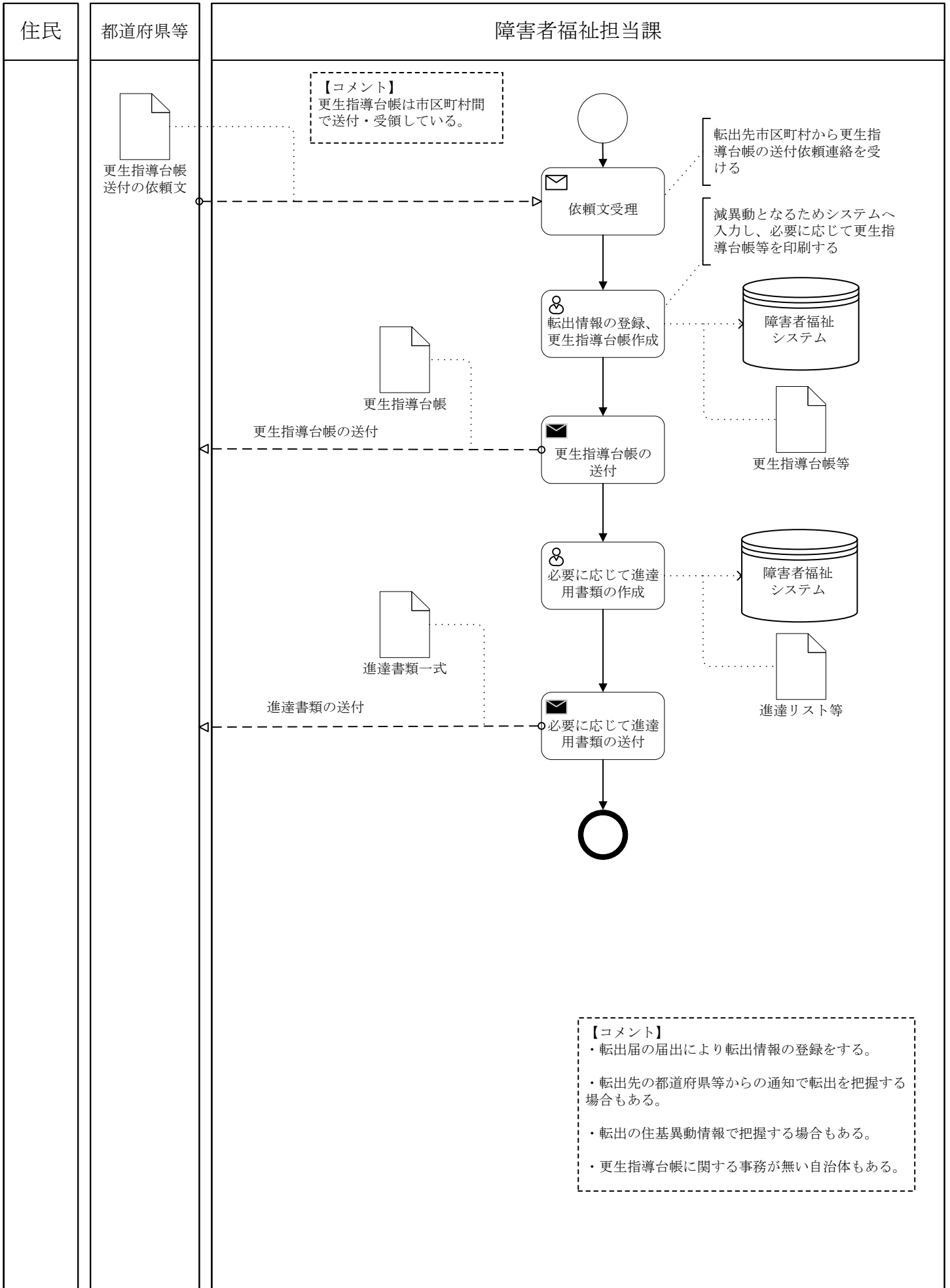

|    |         |     |            |     |           |
|----|---------|-----|------------|-----|-----------|
| 区分 | 1 障害者福祉 | 大分類 | 02 身体障害者手帳 | 小分類 | 06 返還届・死亡 |
|----|---------|-----|------------|-----|-----------|

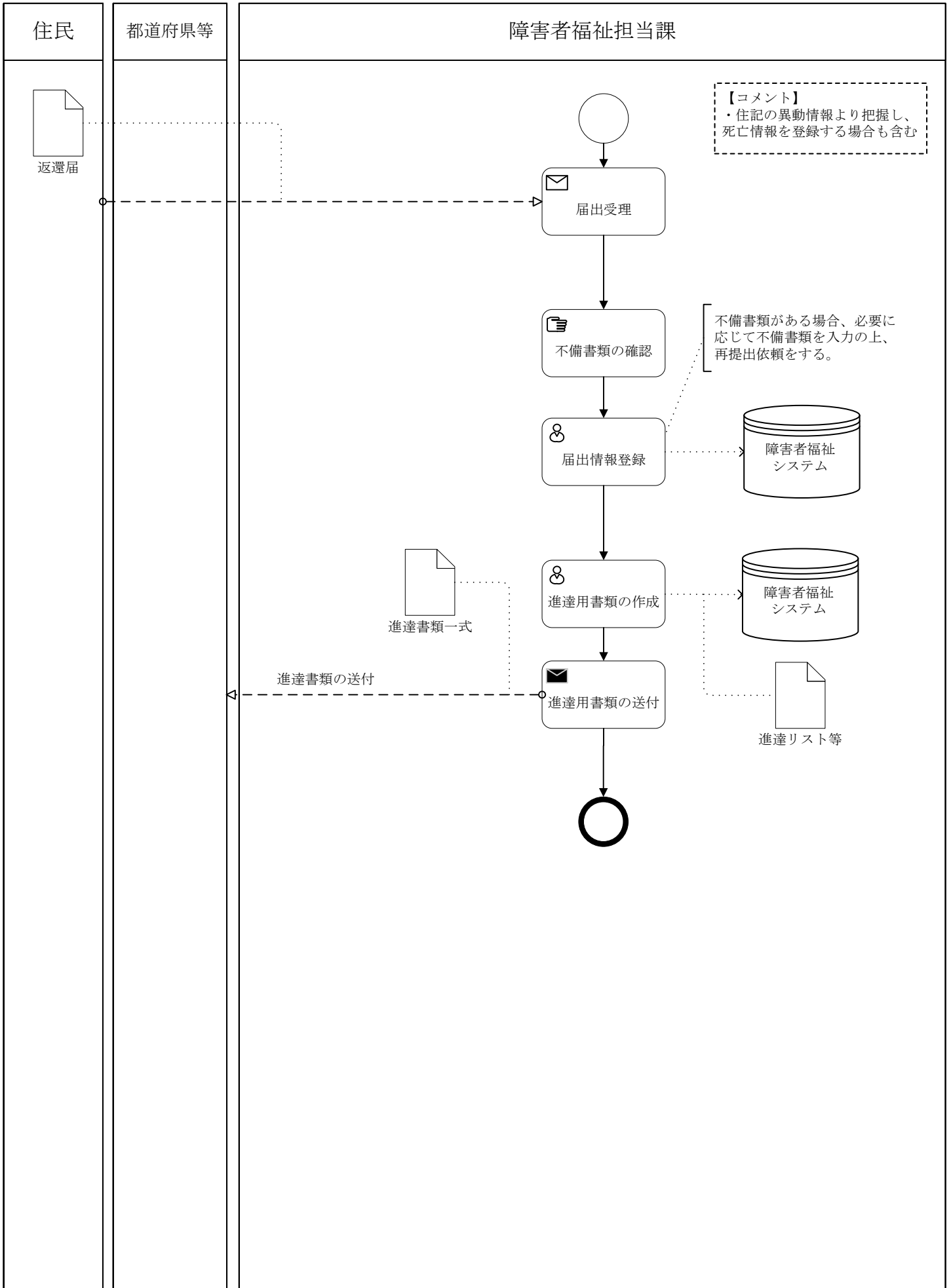

|    |         |     |            |     |        |
|----|---------|-----|------------|-----|--------|
| 区分 | 1 障害者福祉 | 大分類 | 02 身体障害者手帳 | 小分類 | 07 再認定 |
|----|---------|-----|------------|-----|--------|

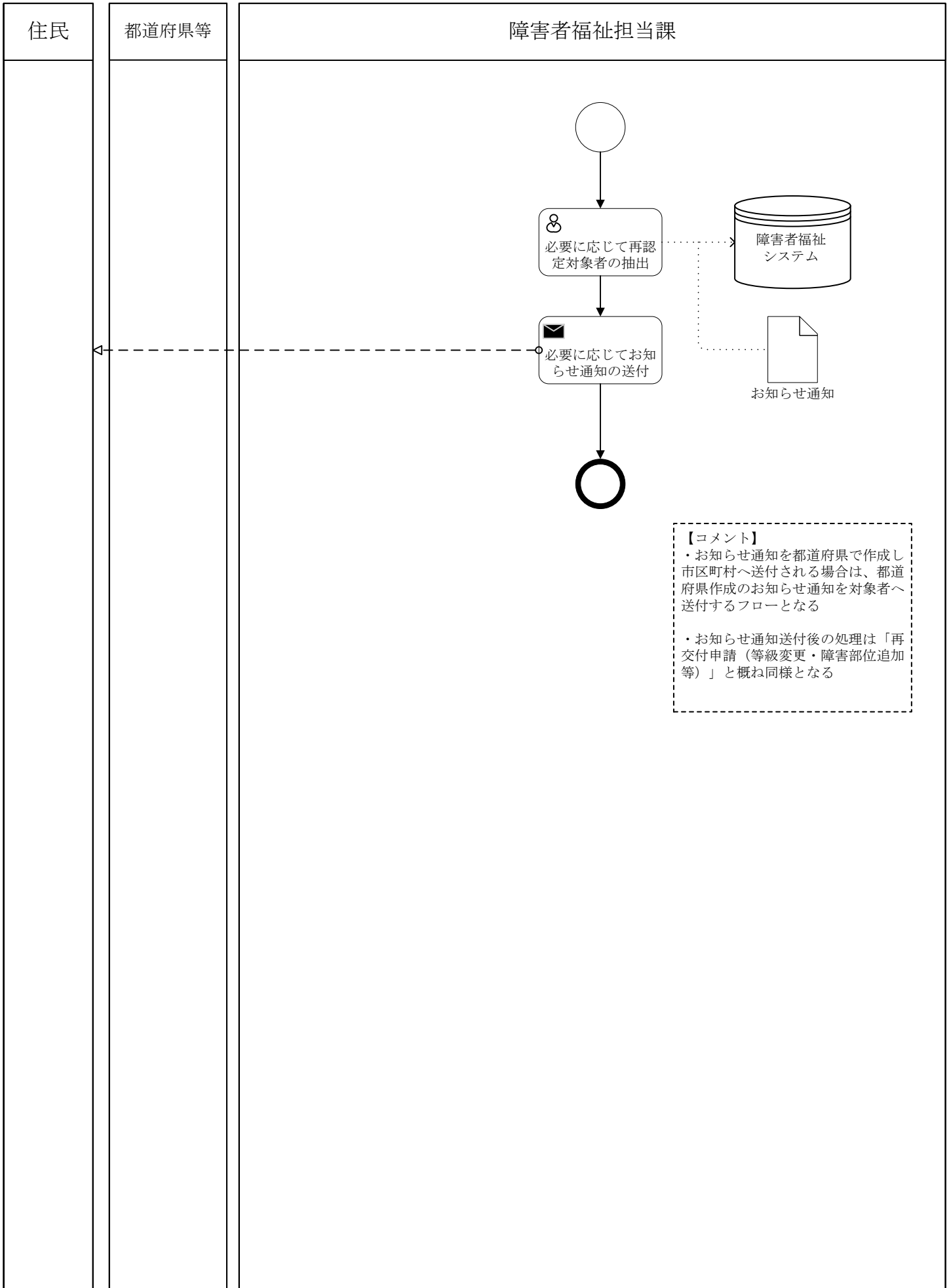

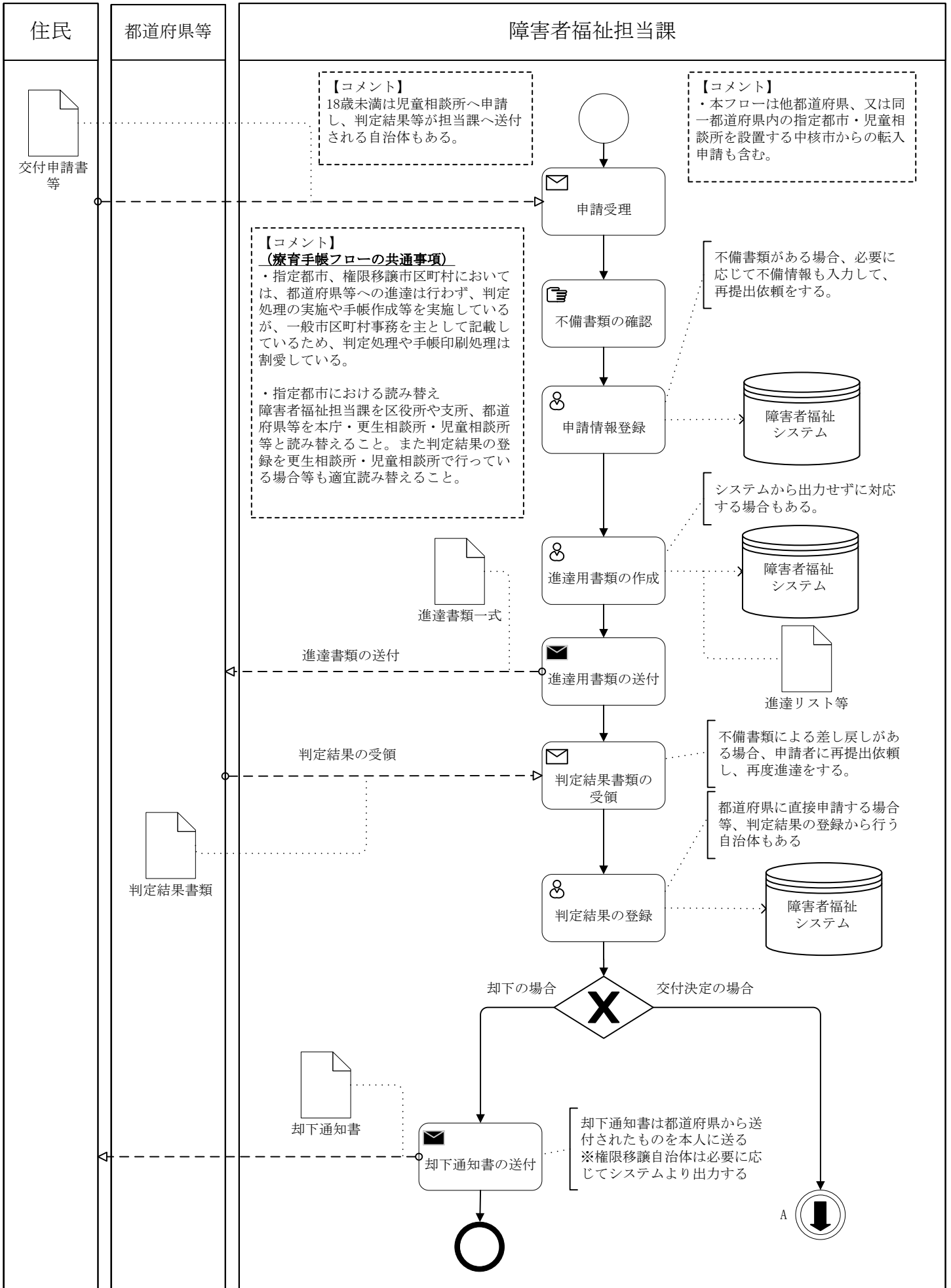

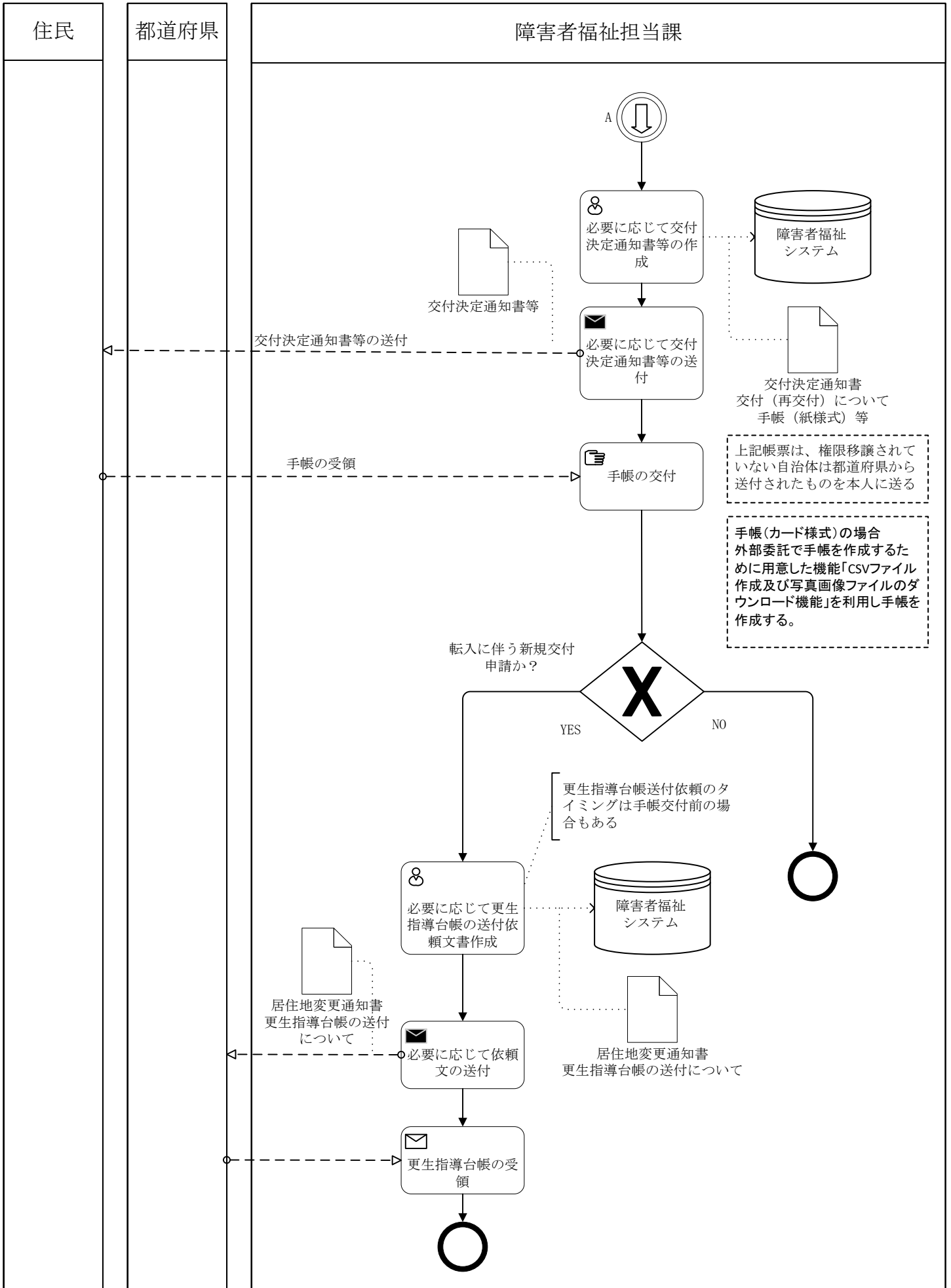

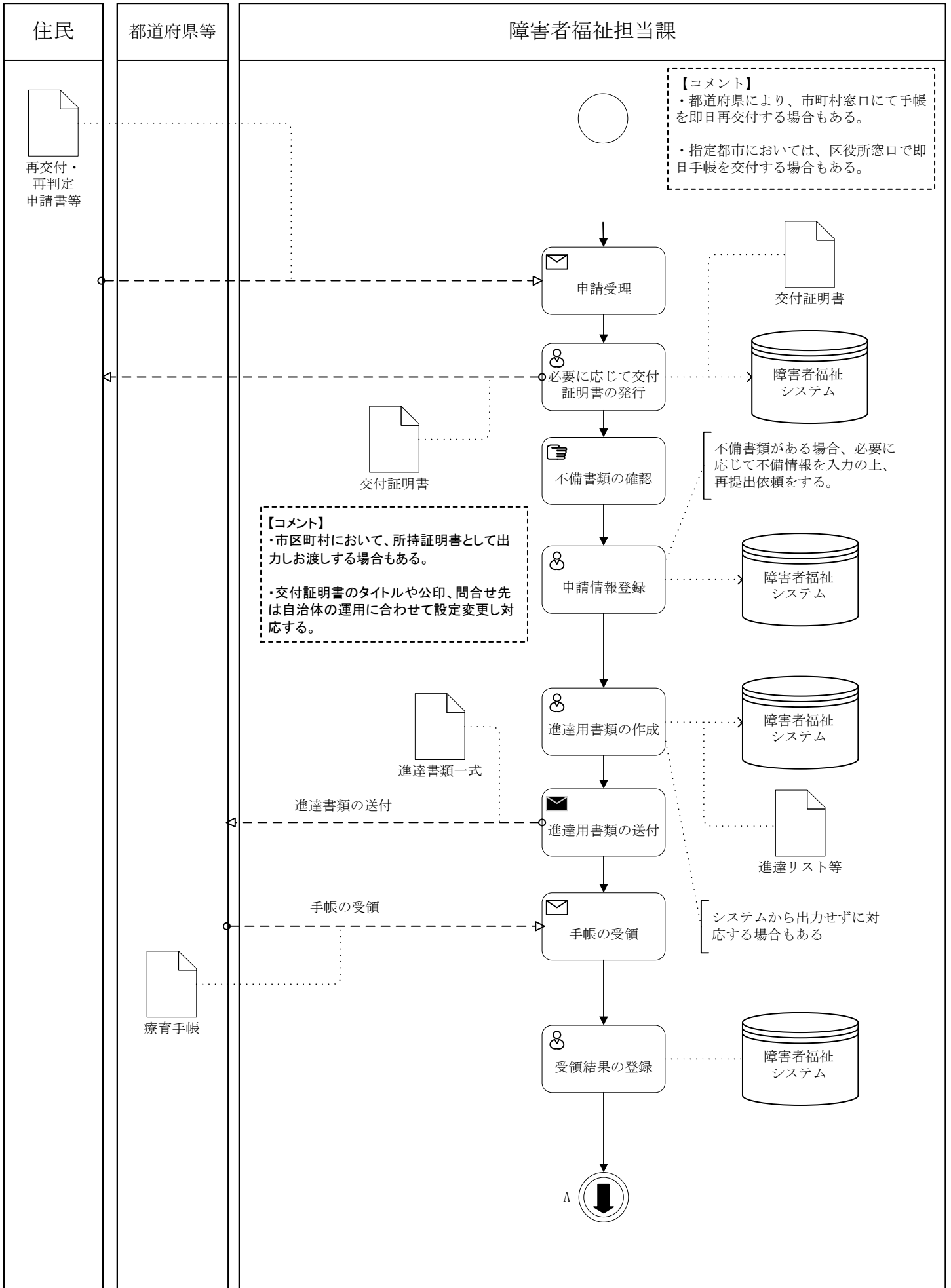

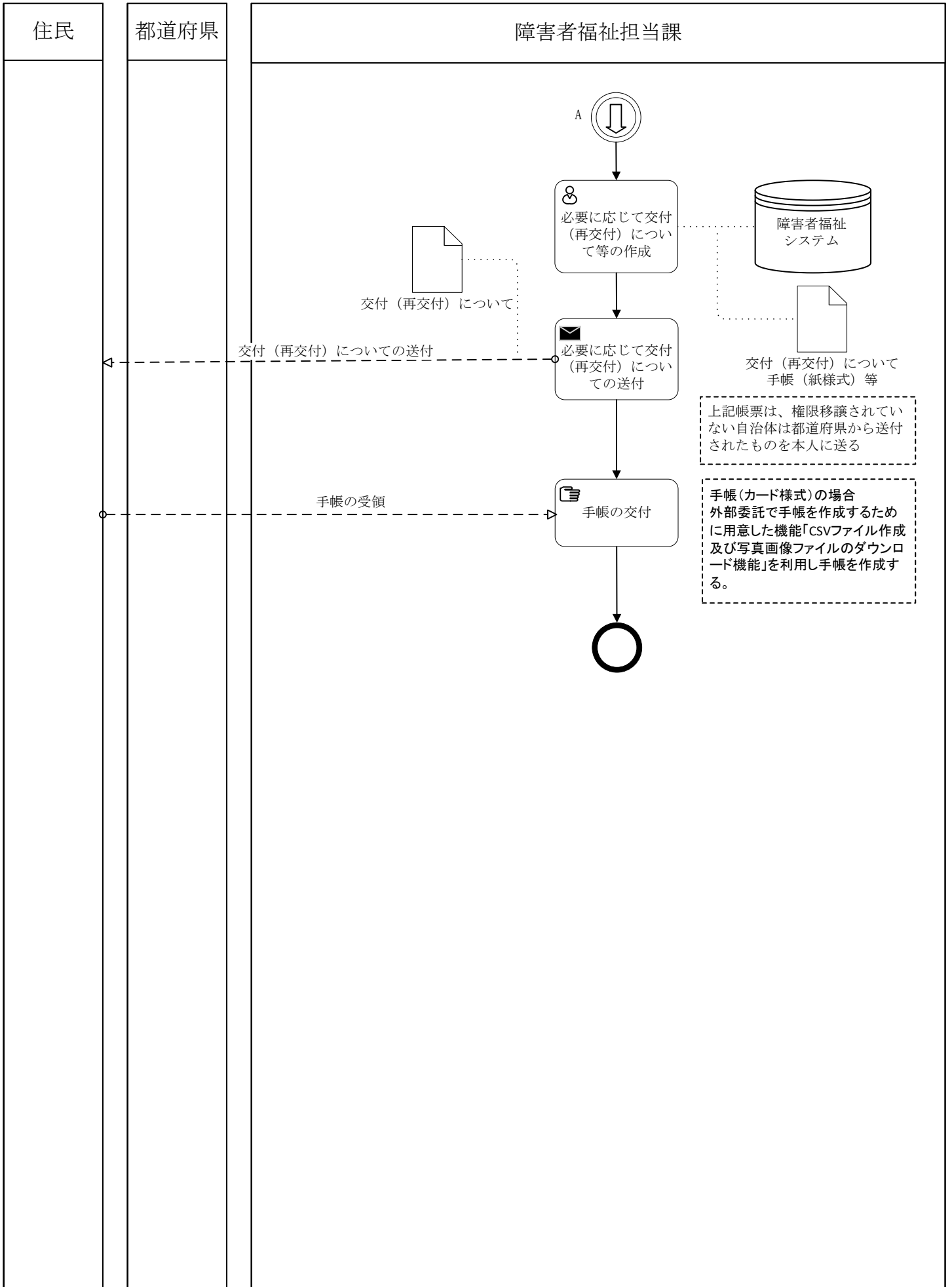



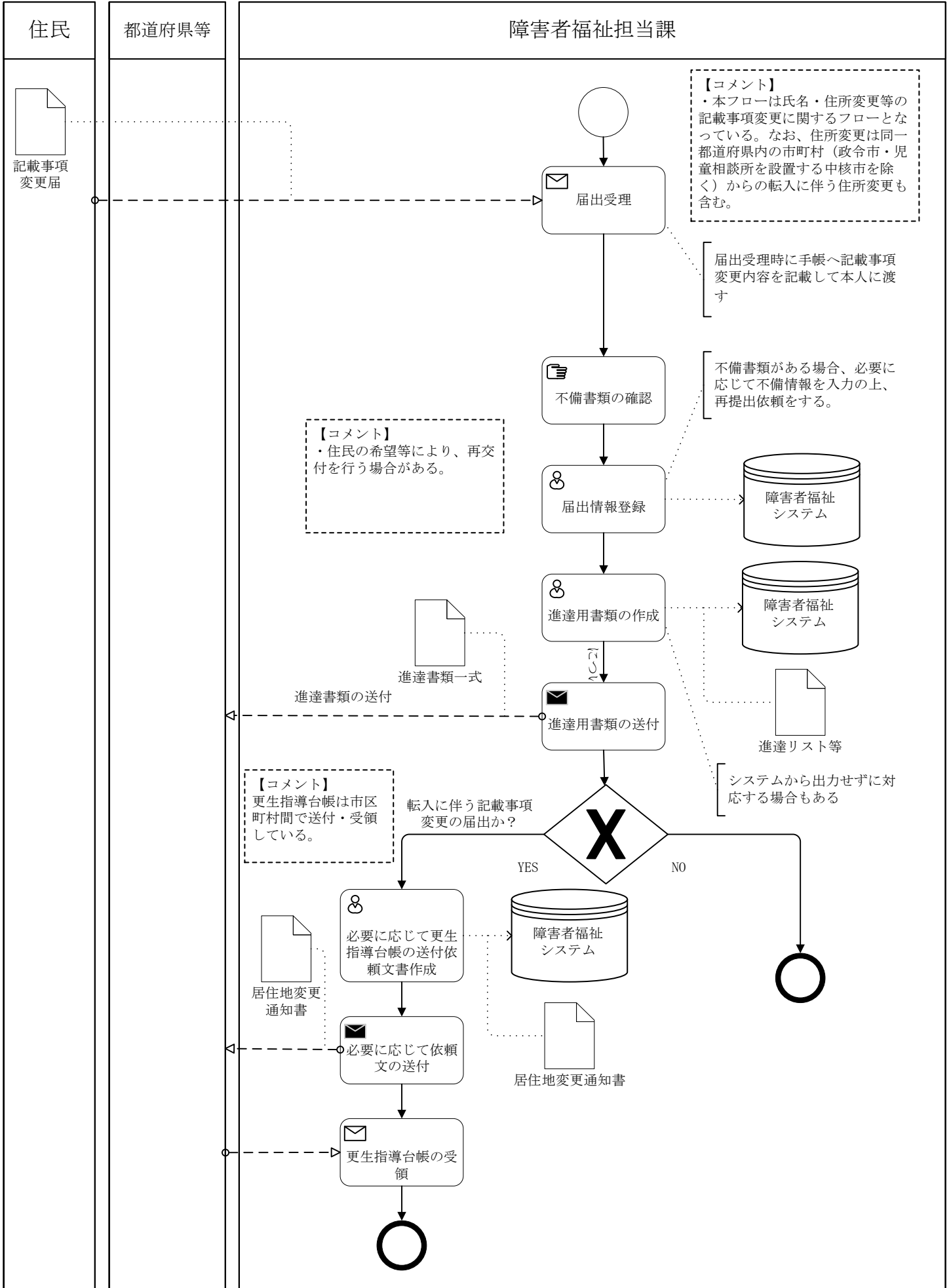

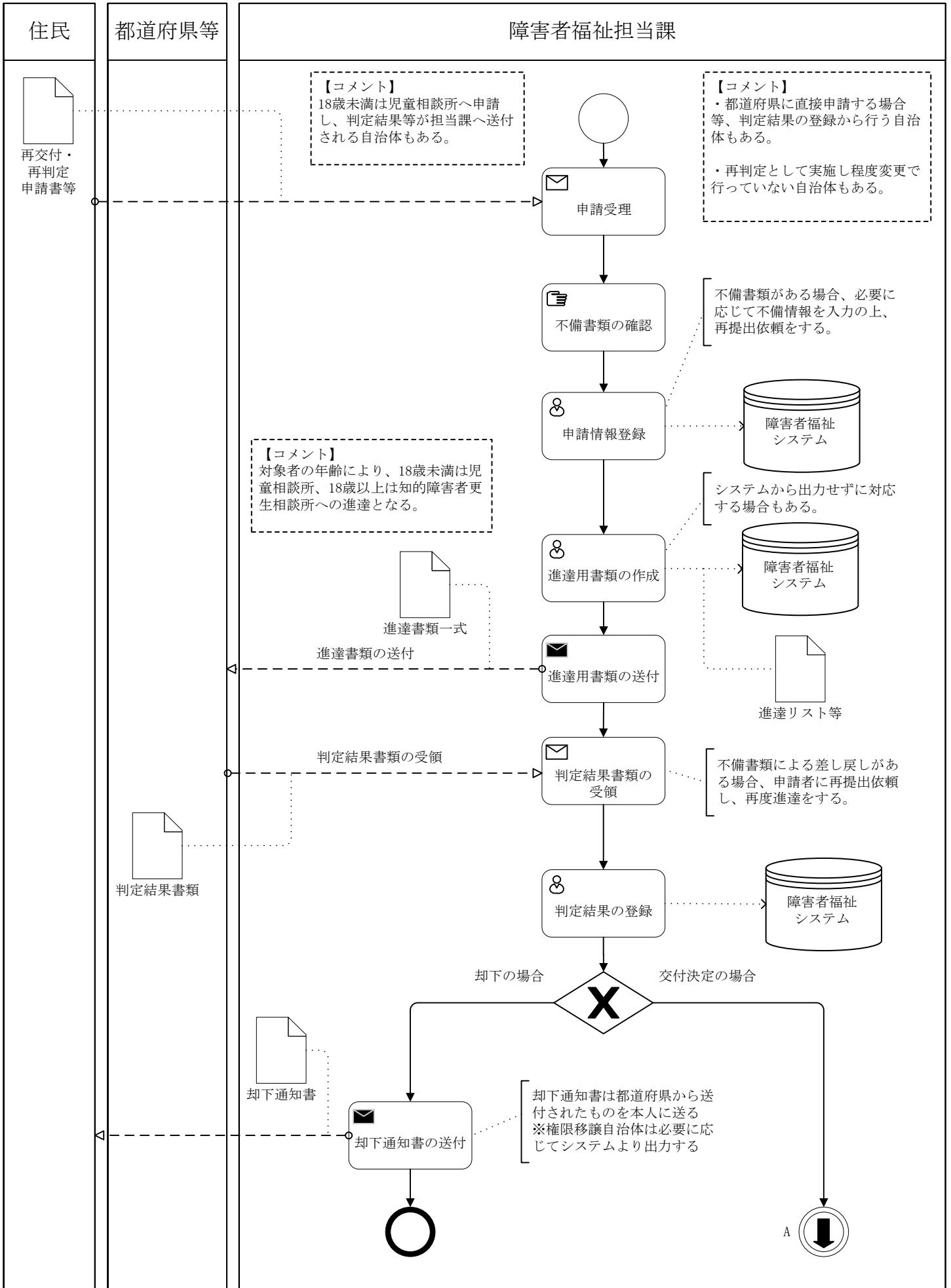

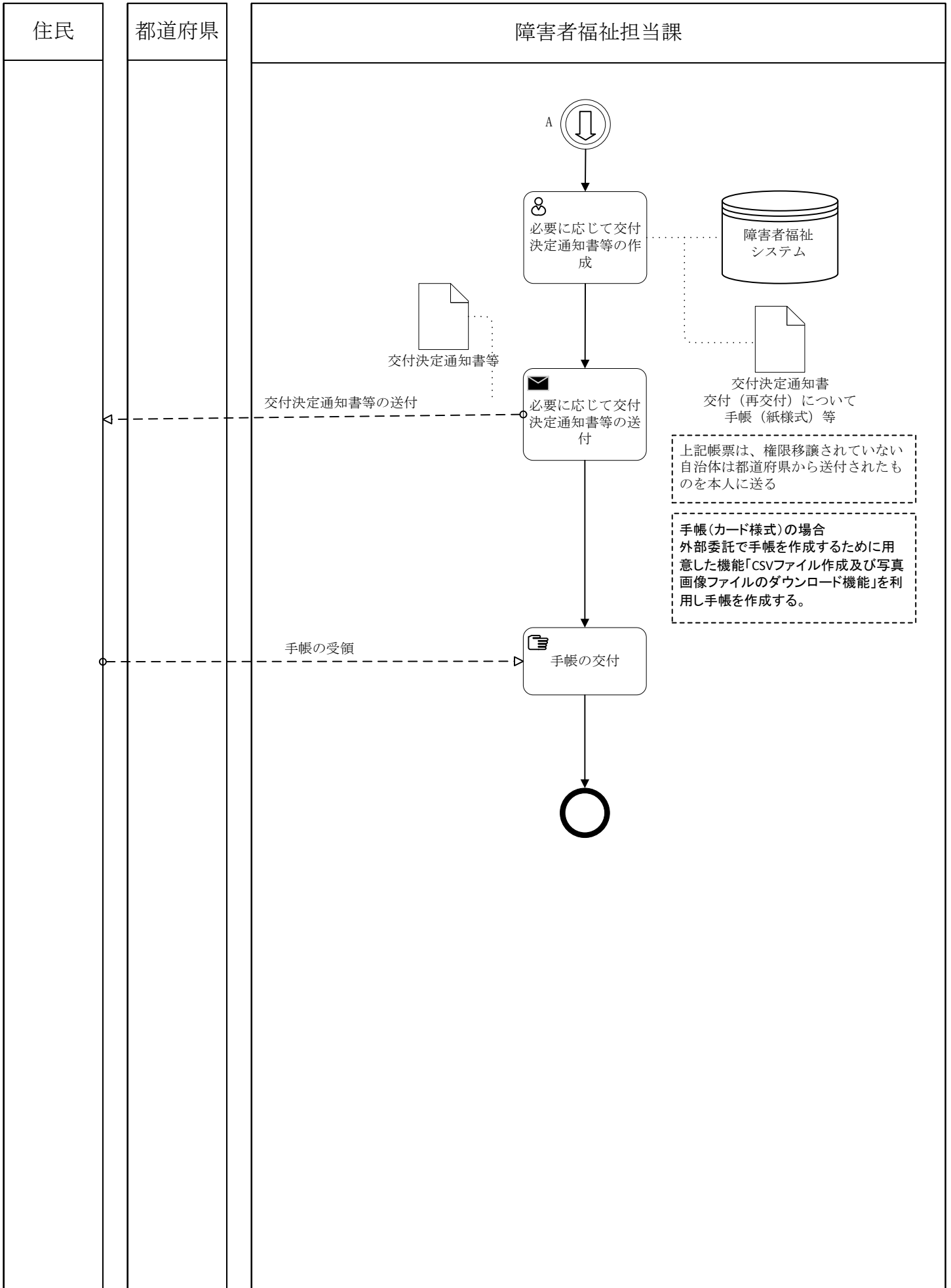

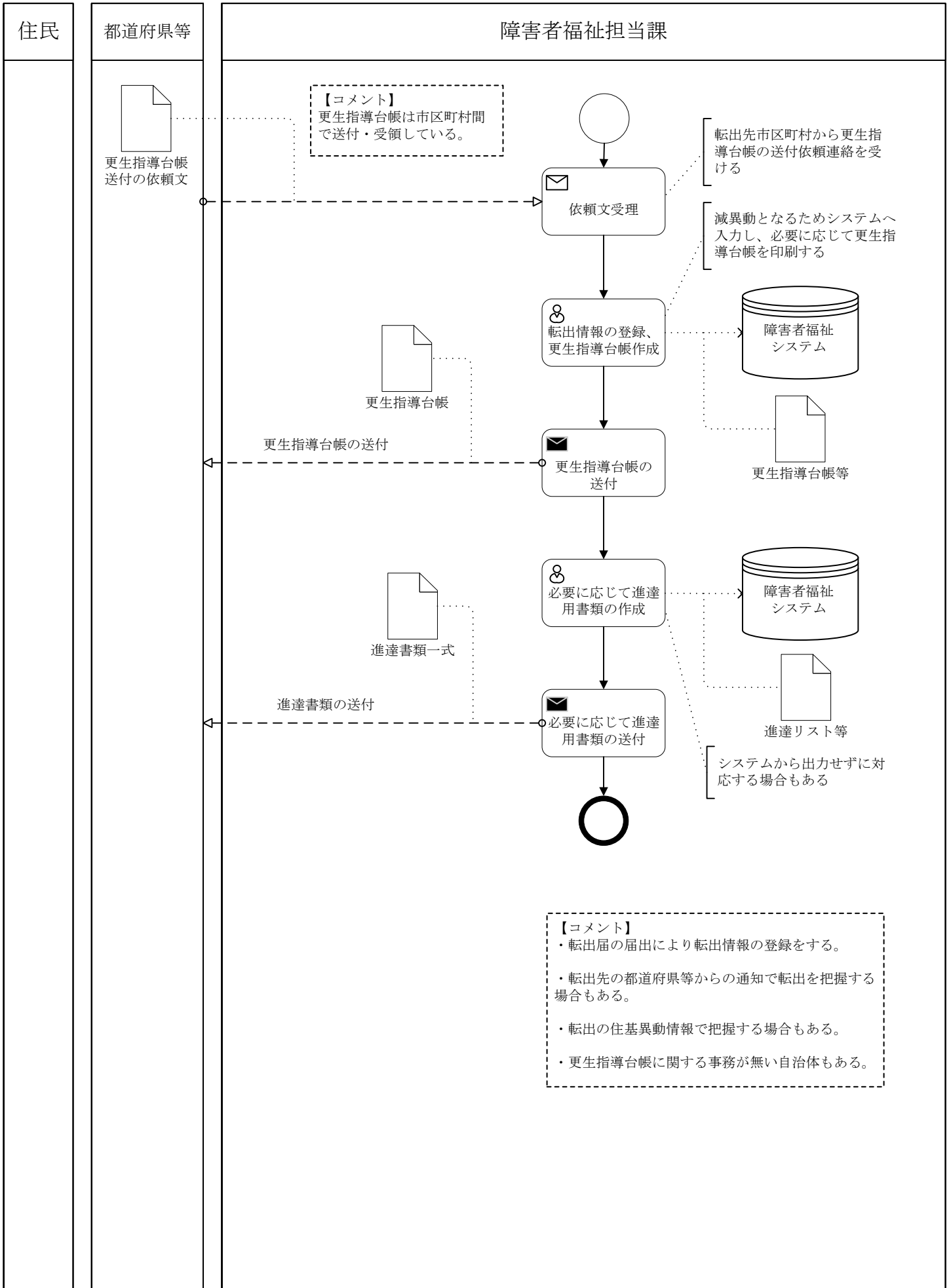

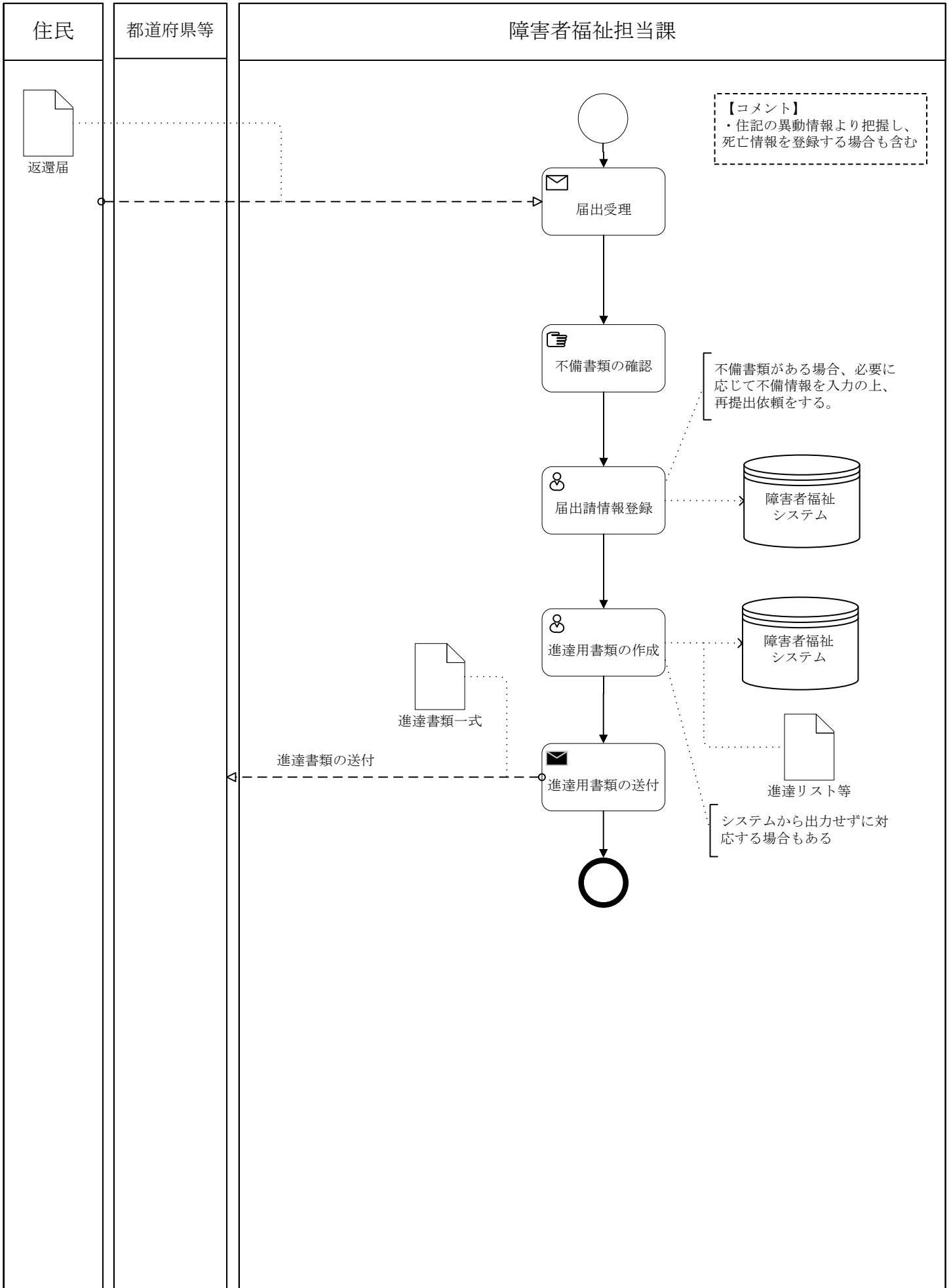

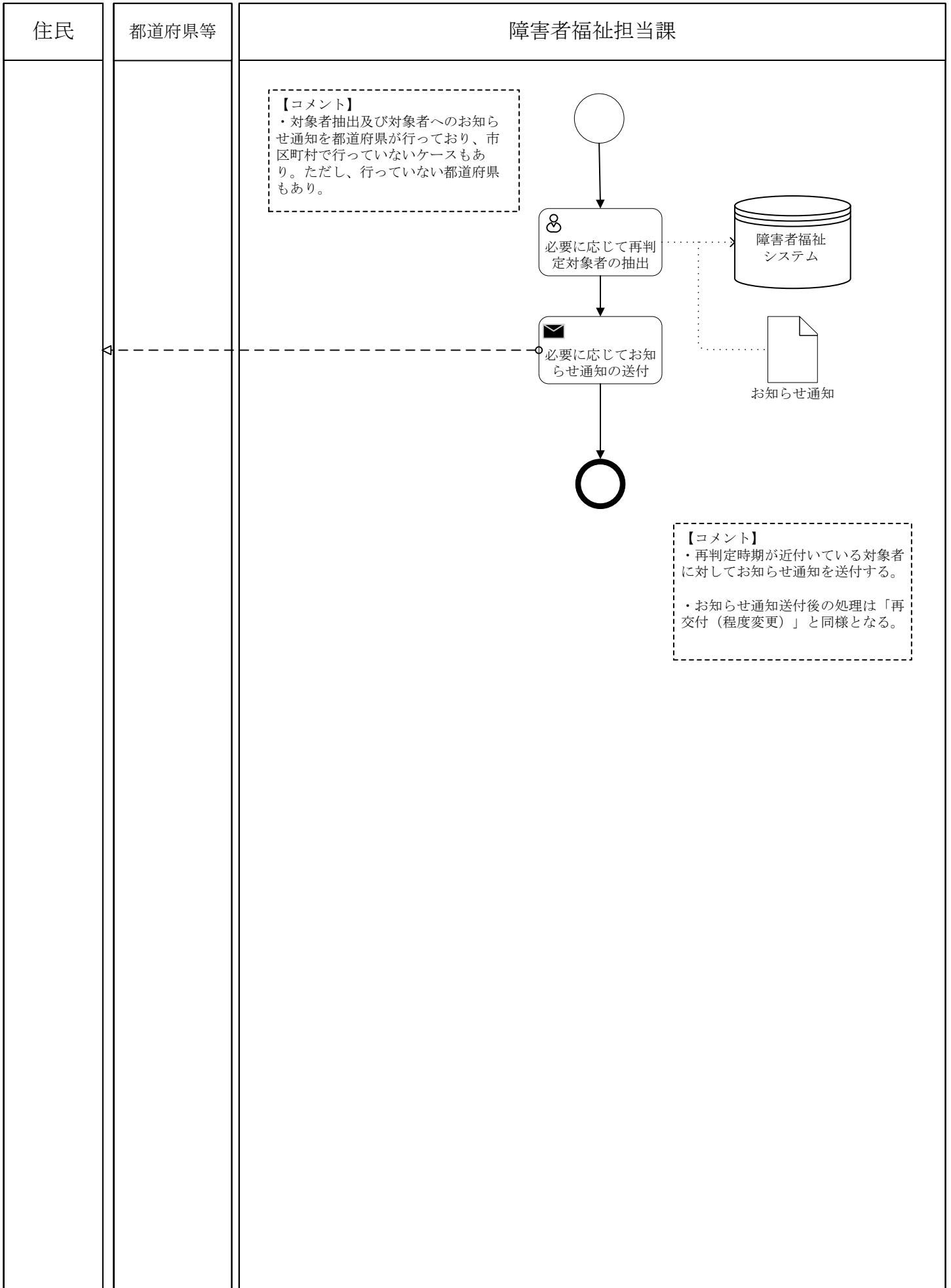

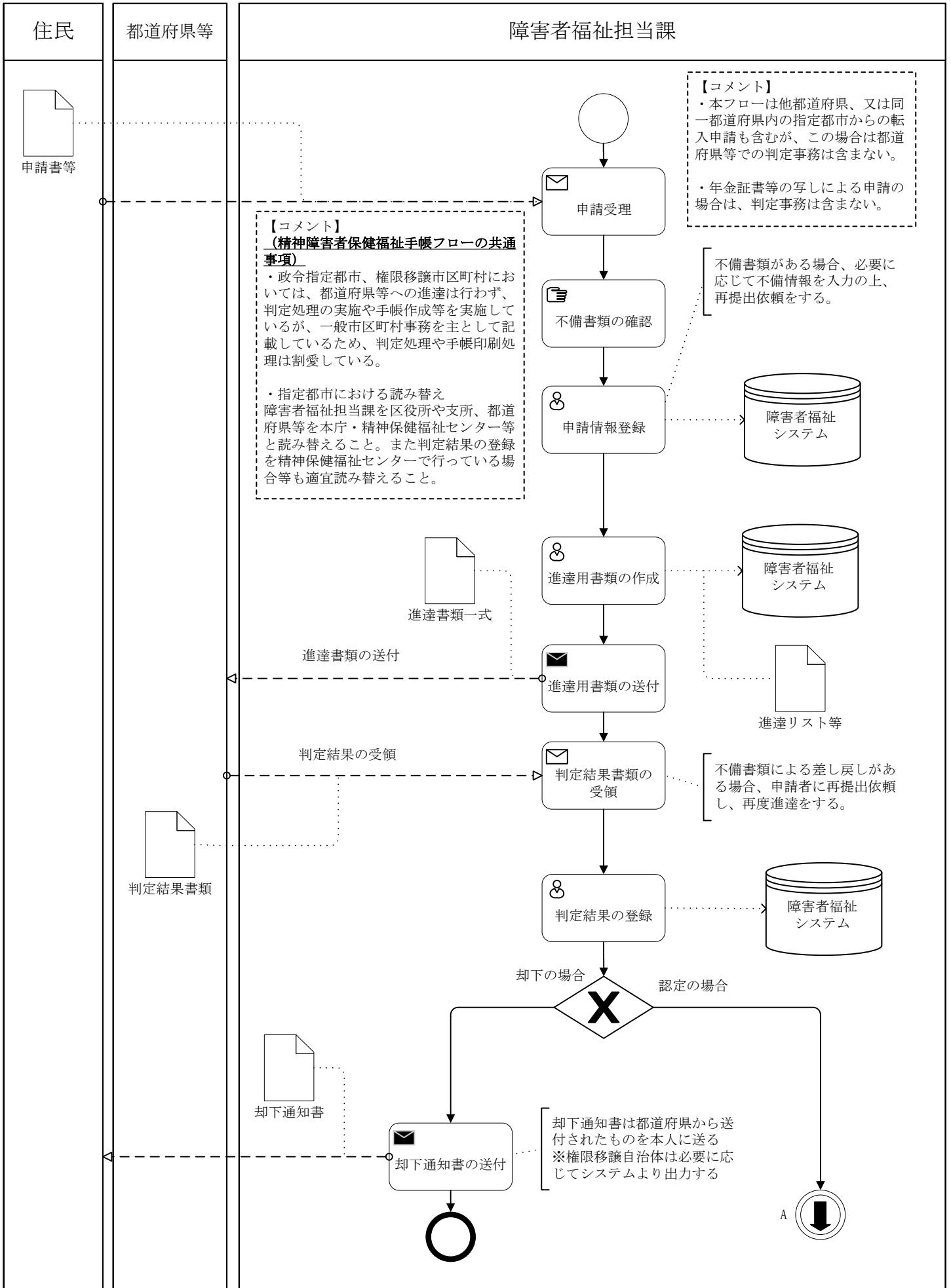

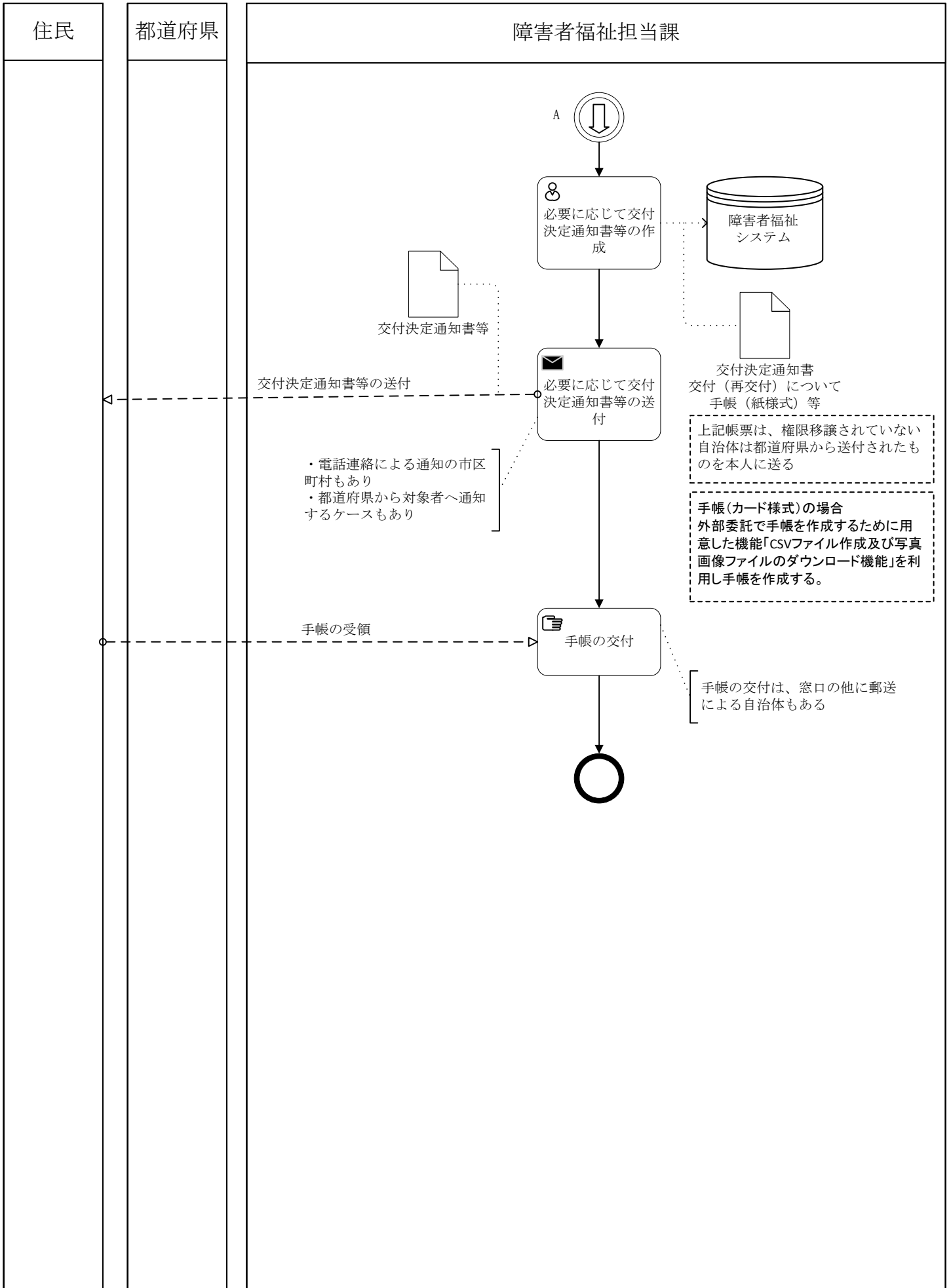



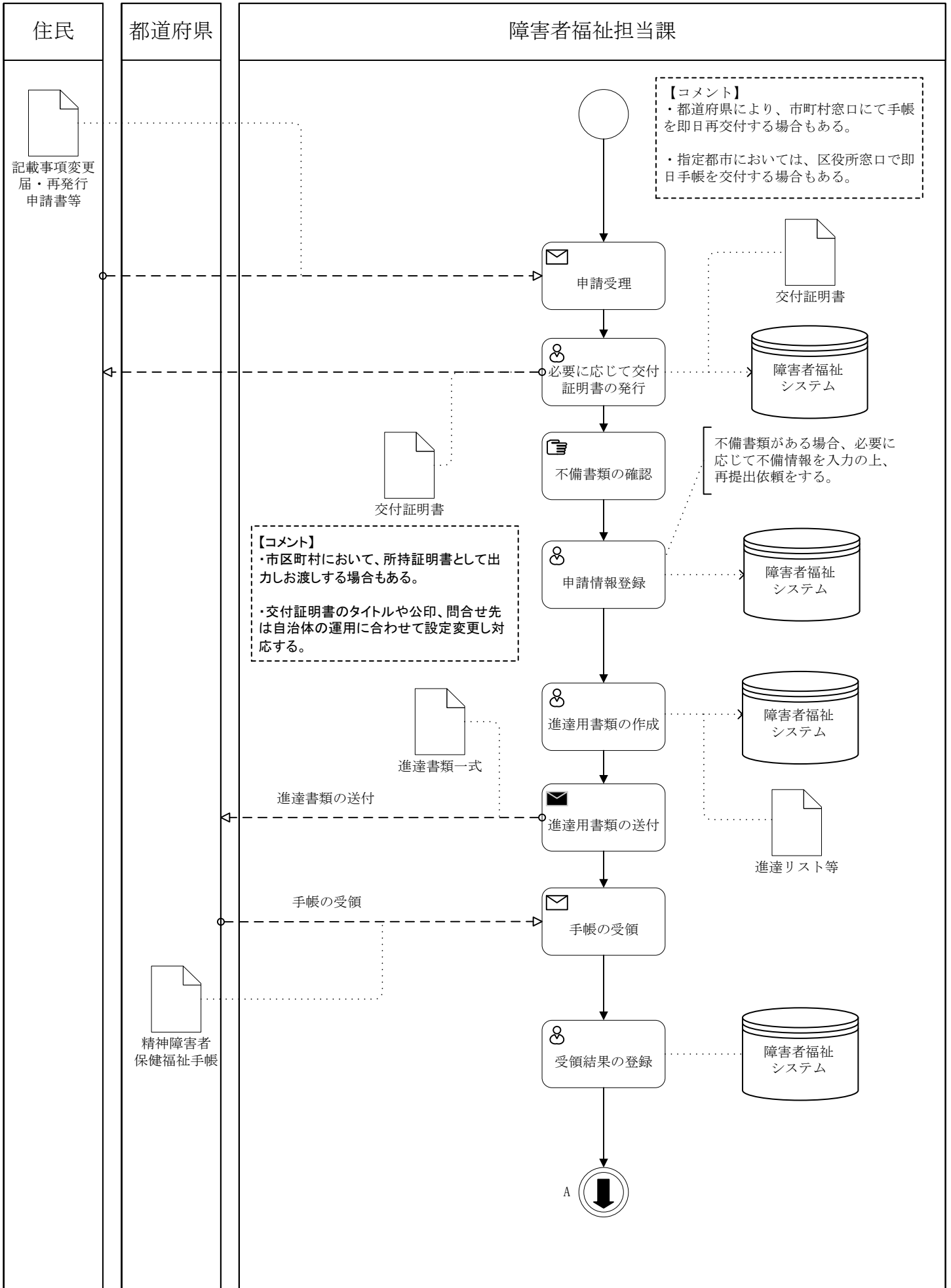

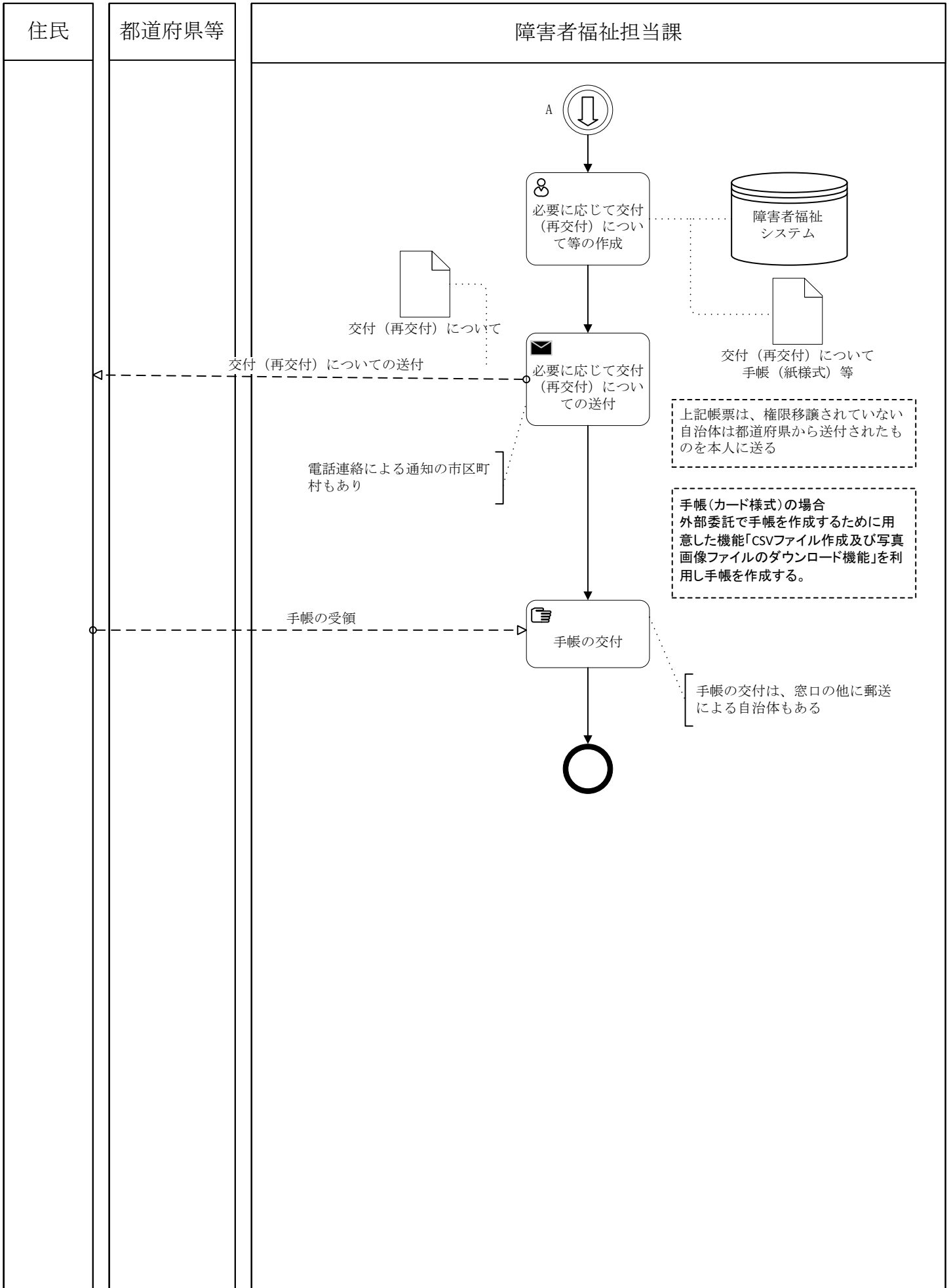

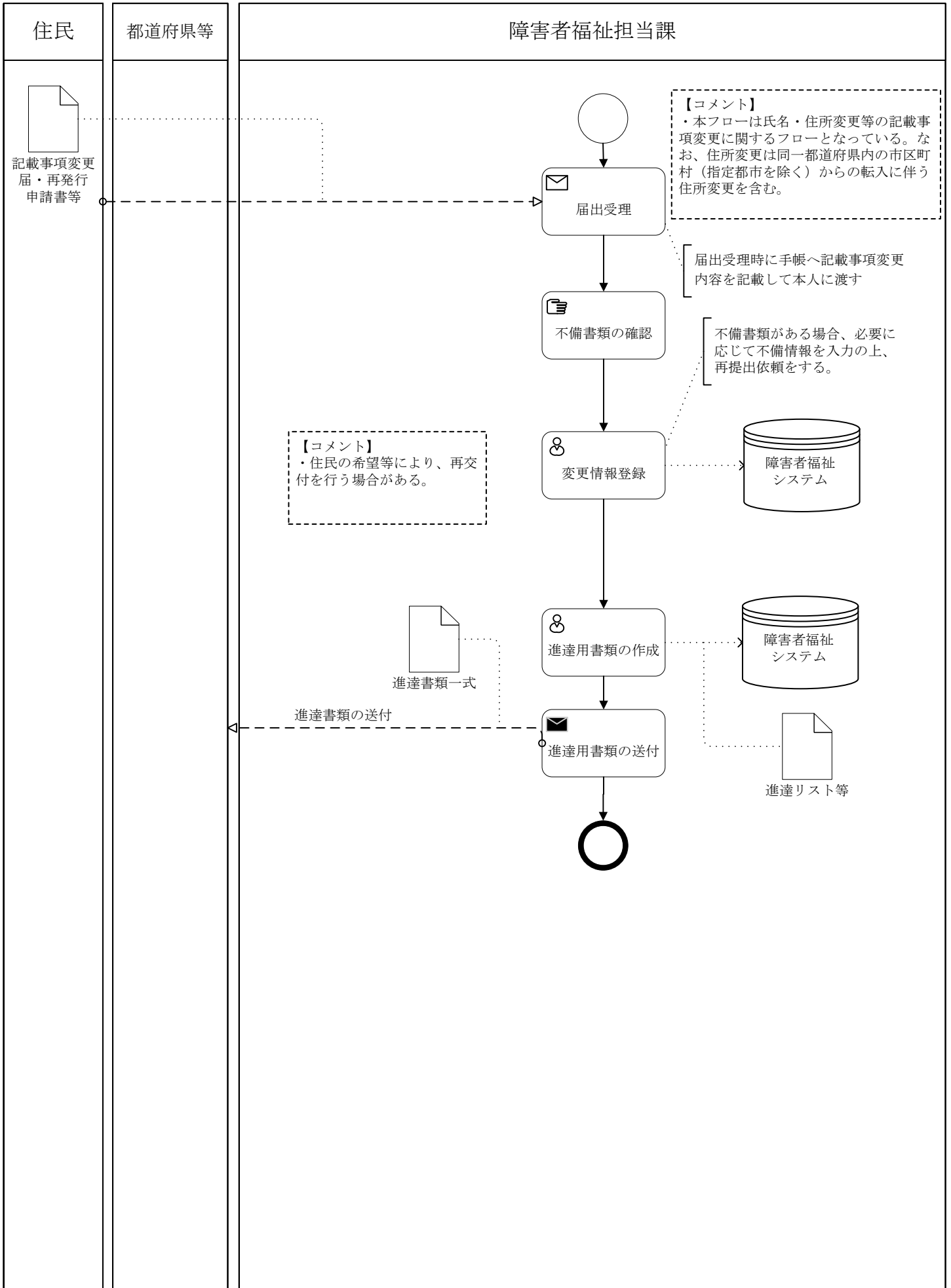

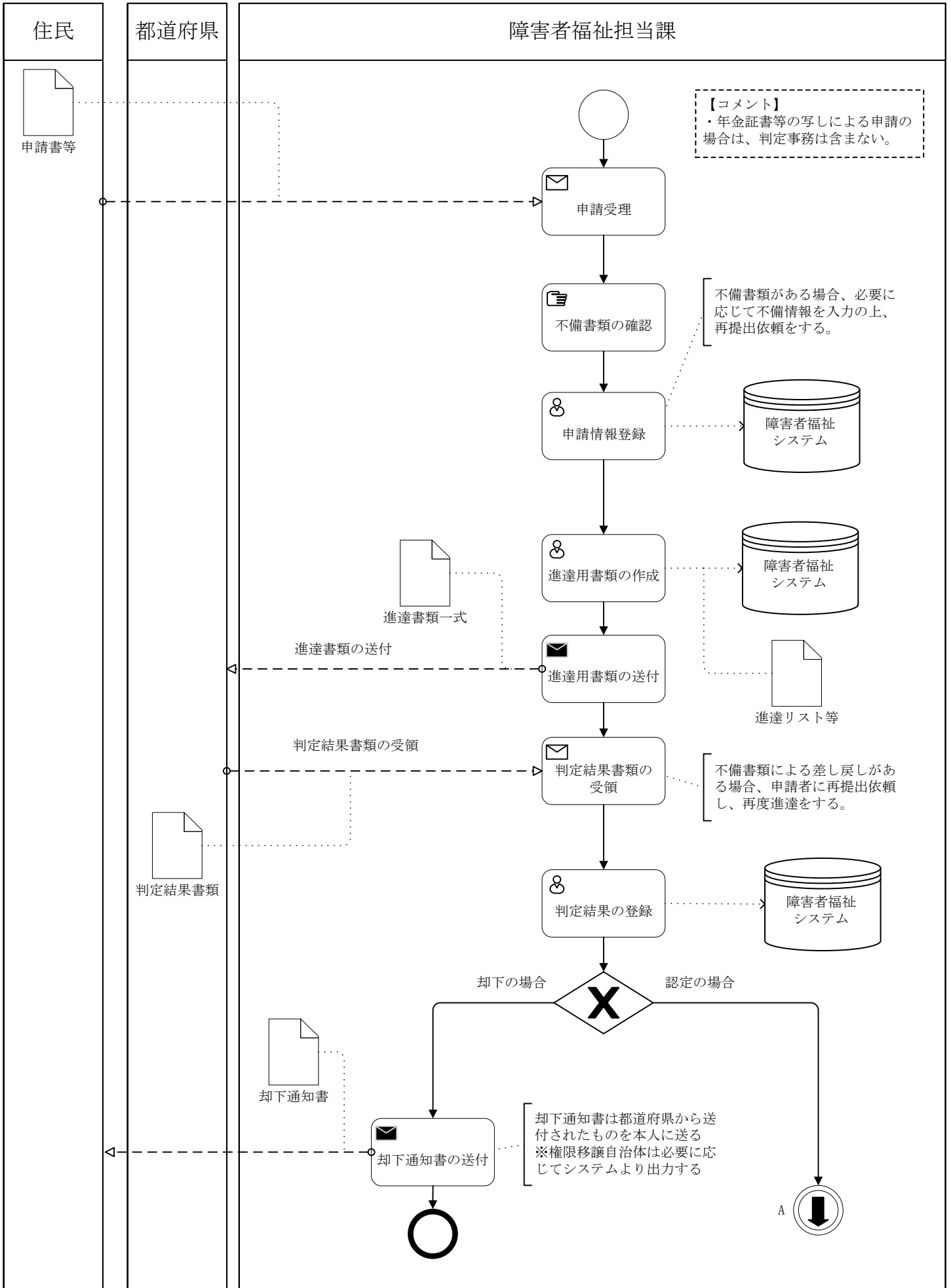

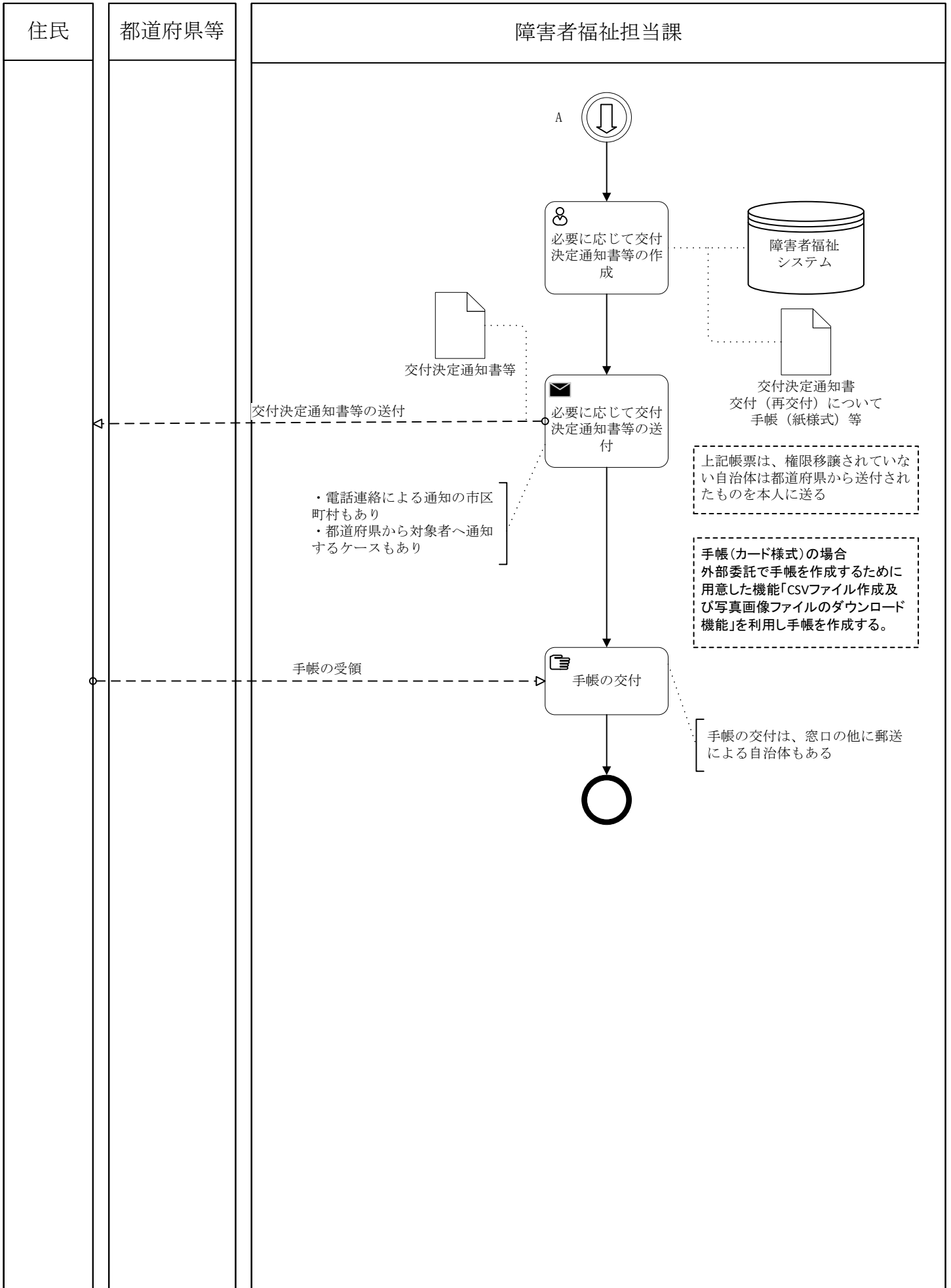

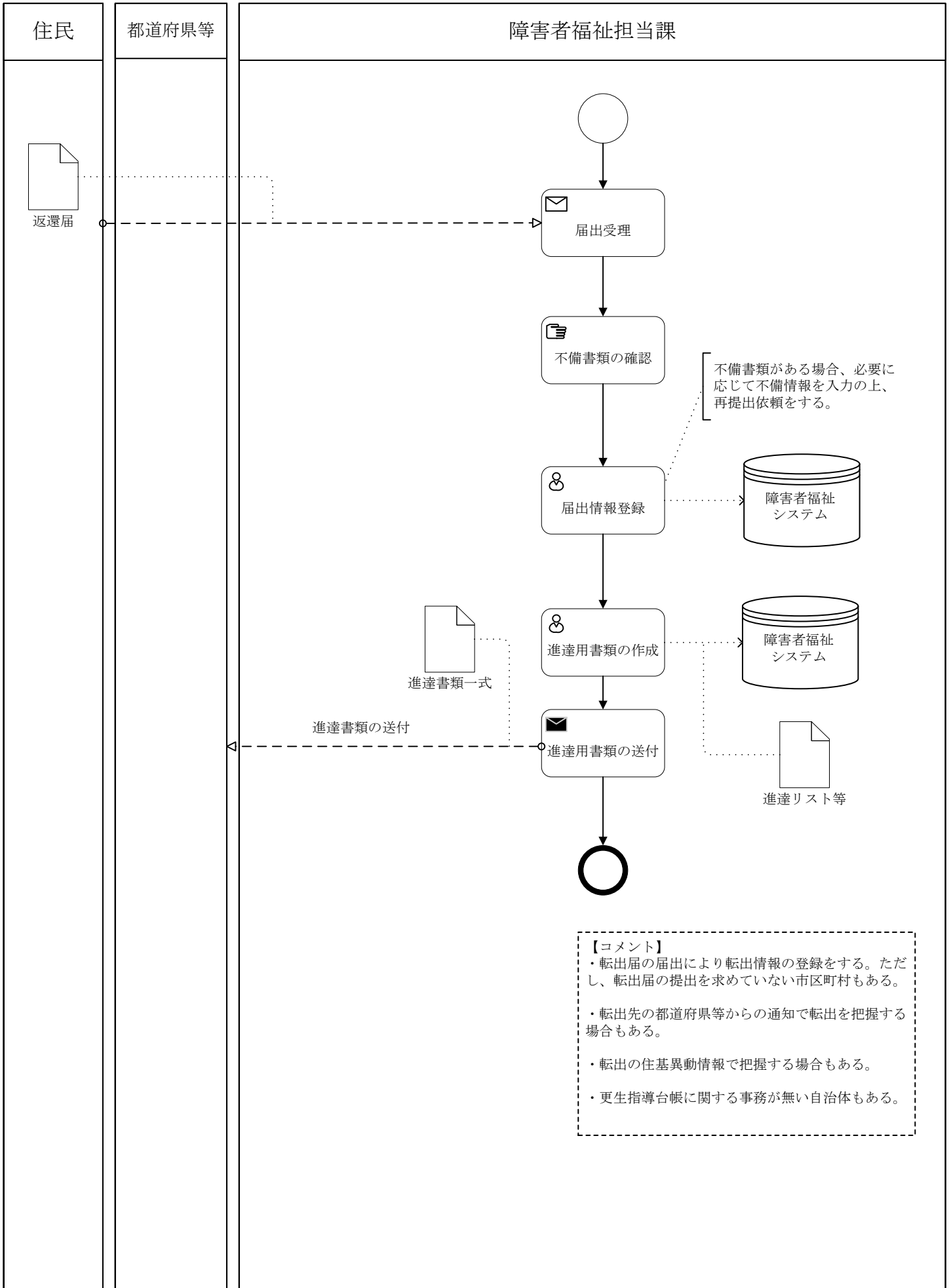

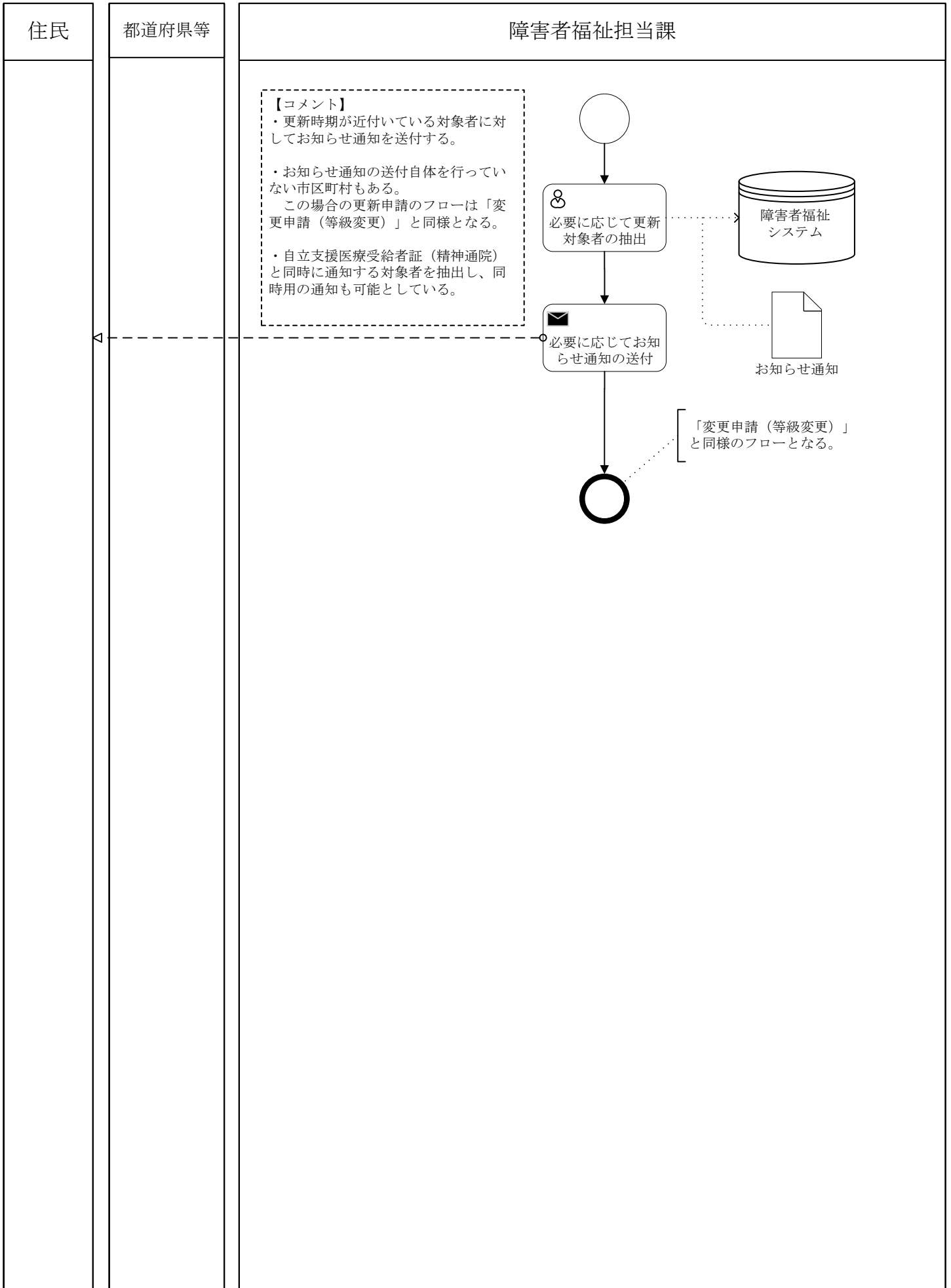

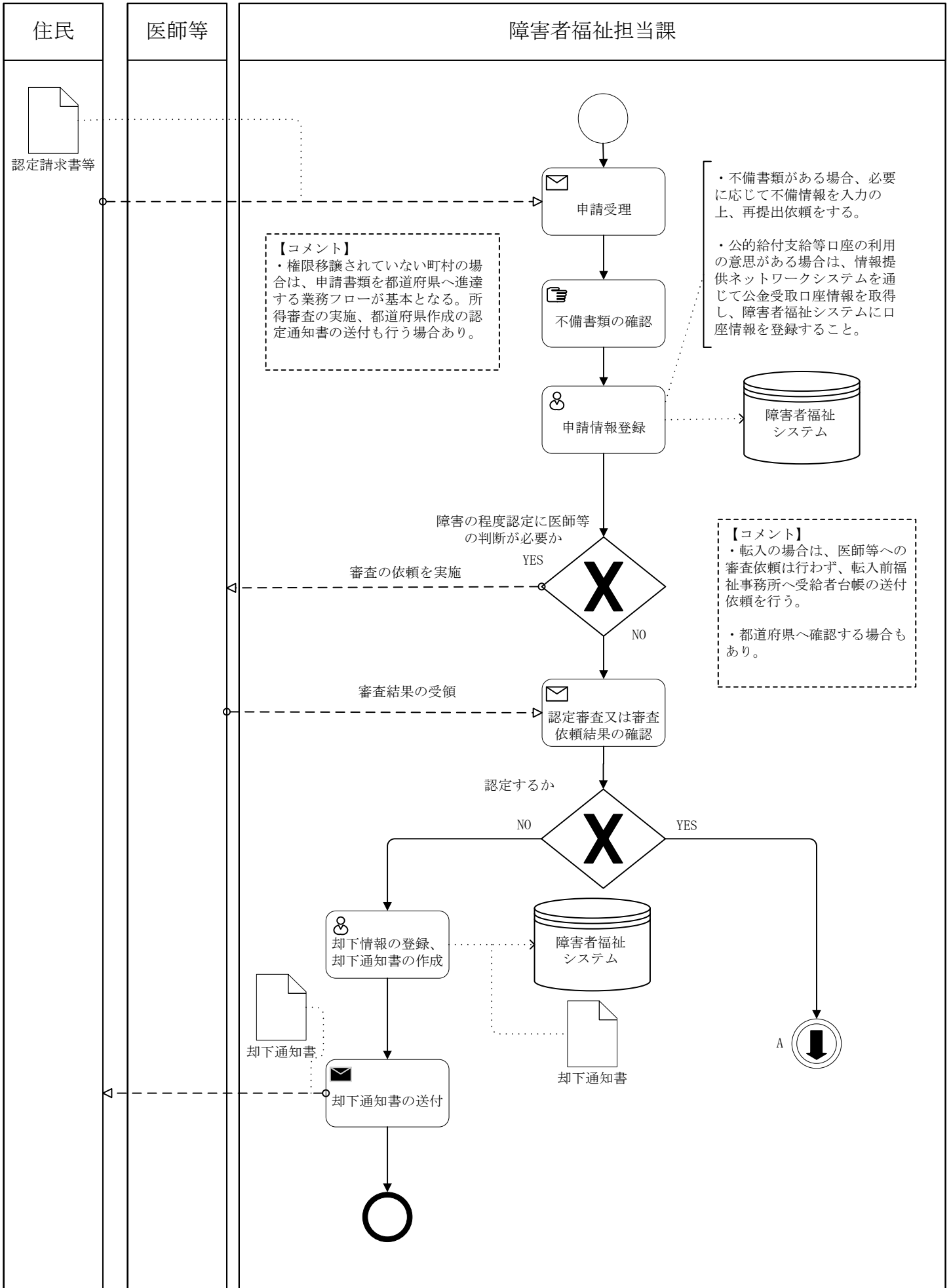



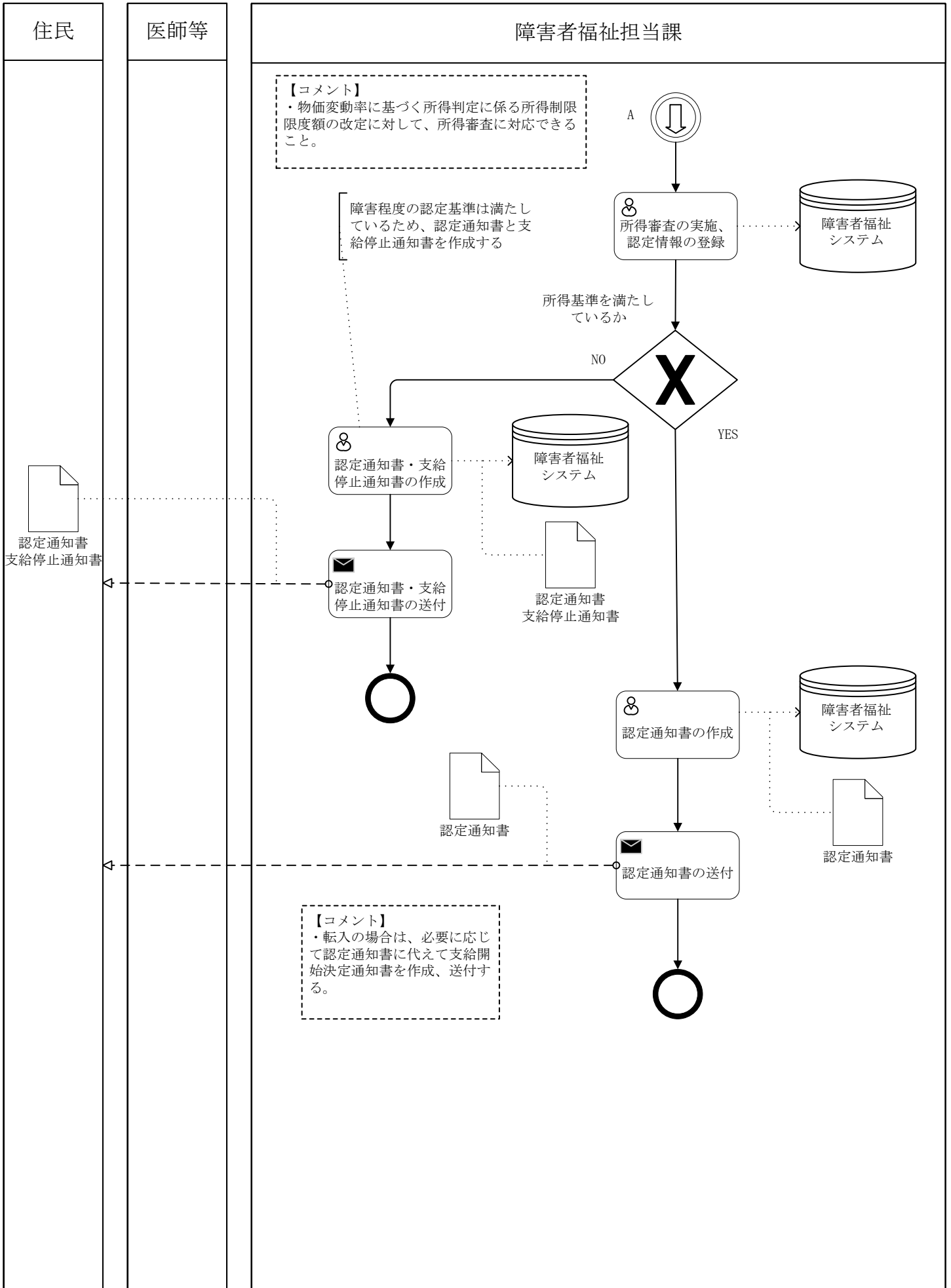

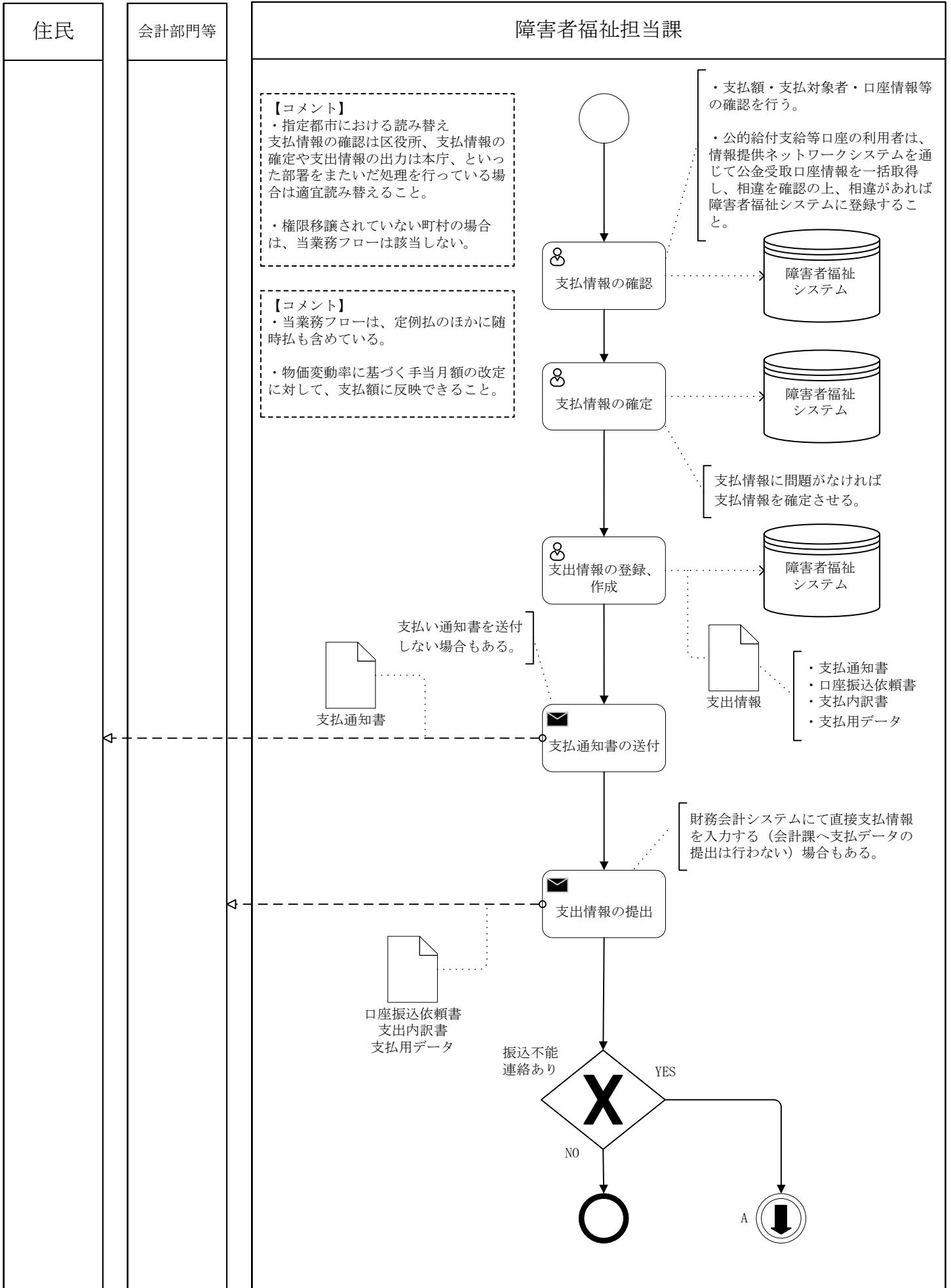

住民

会計部門等

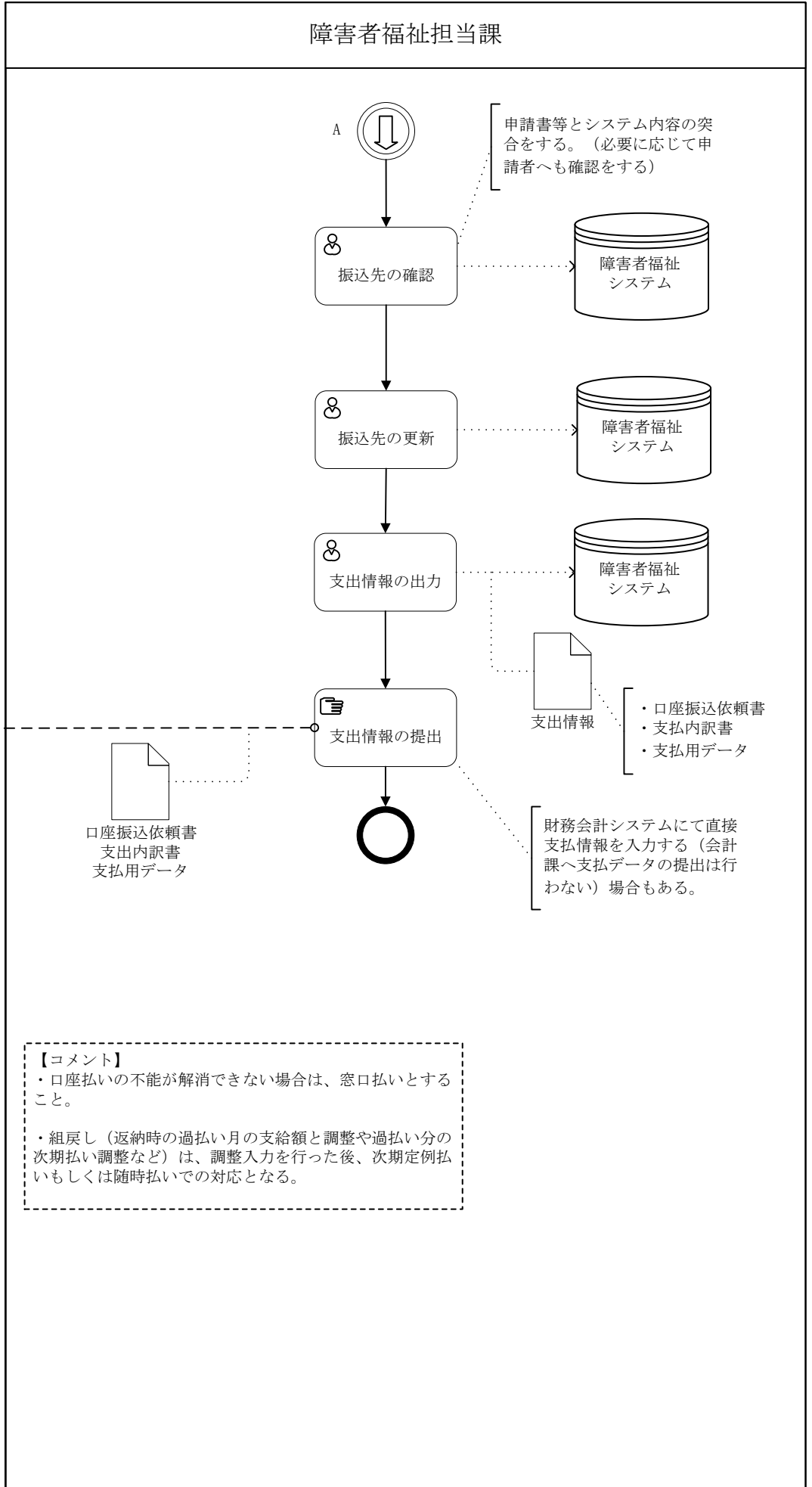

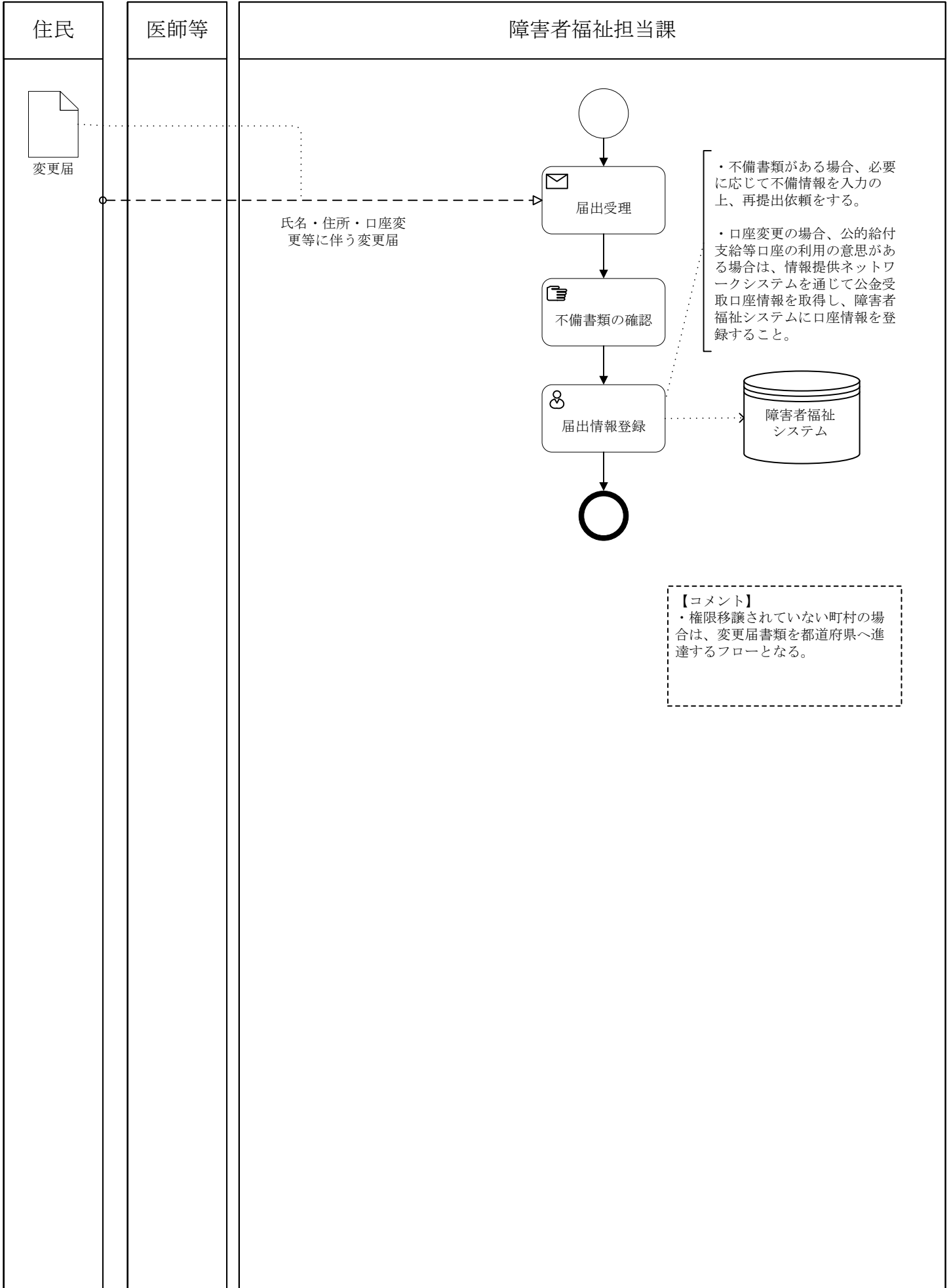

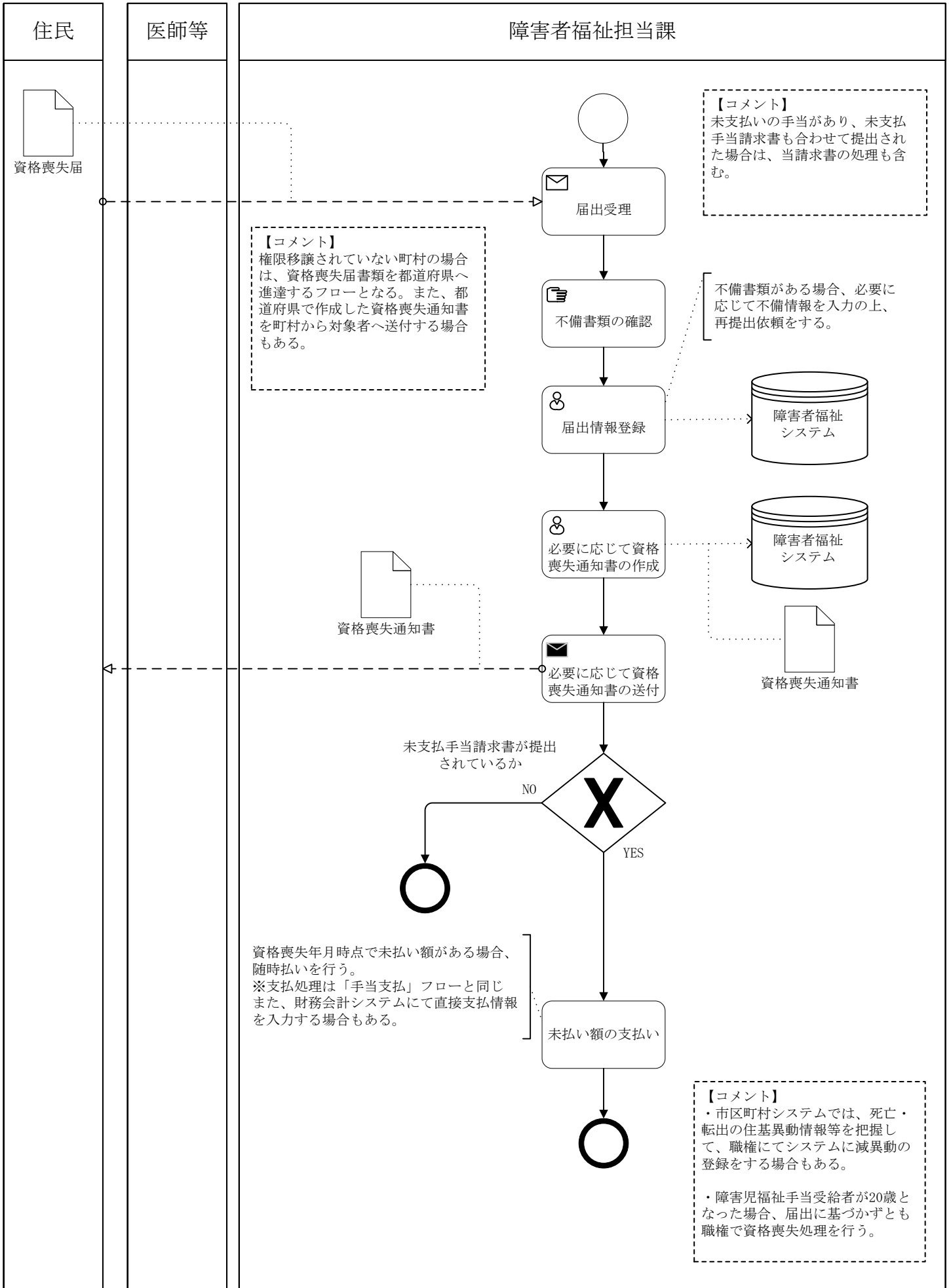

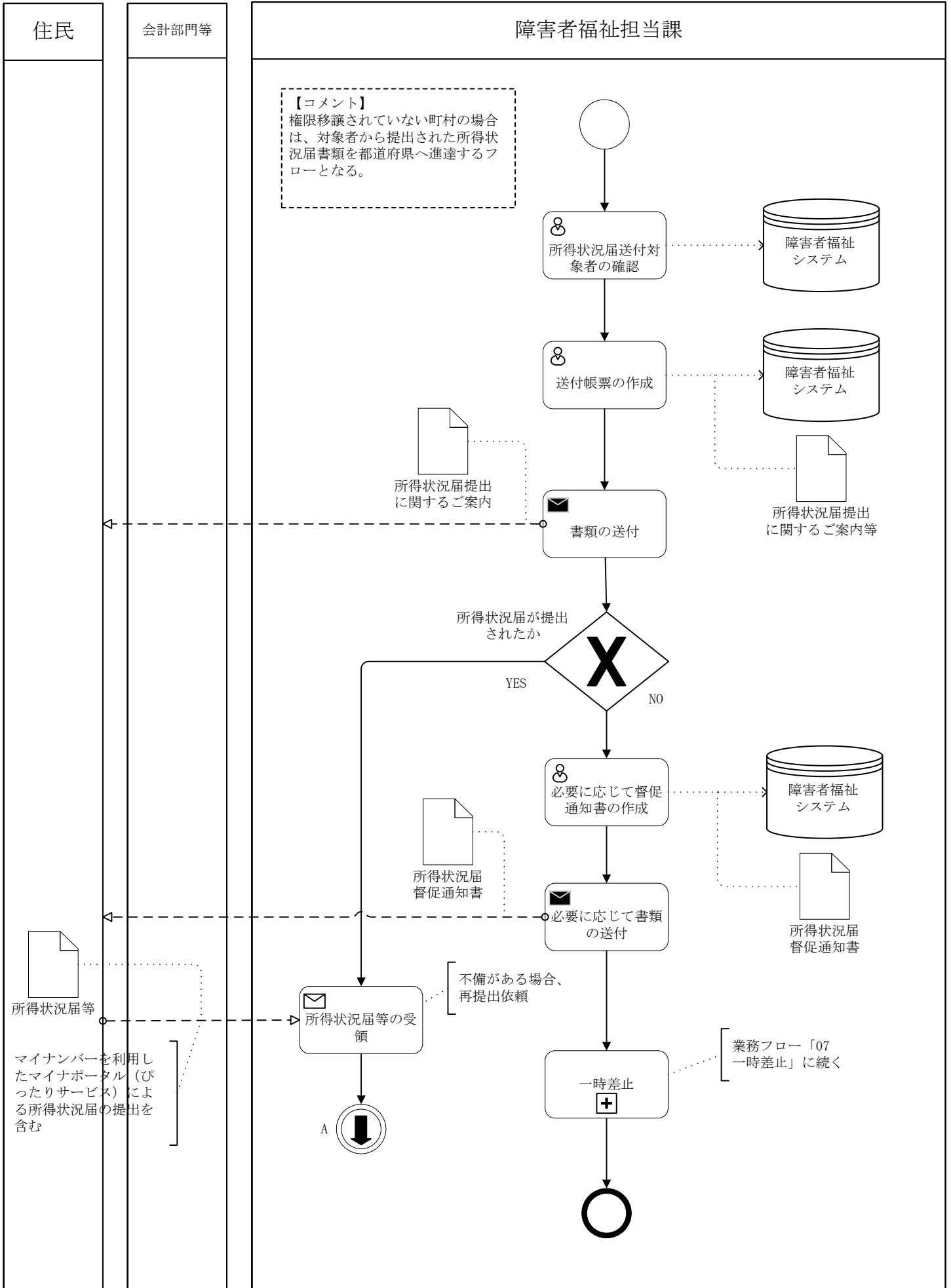

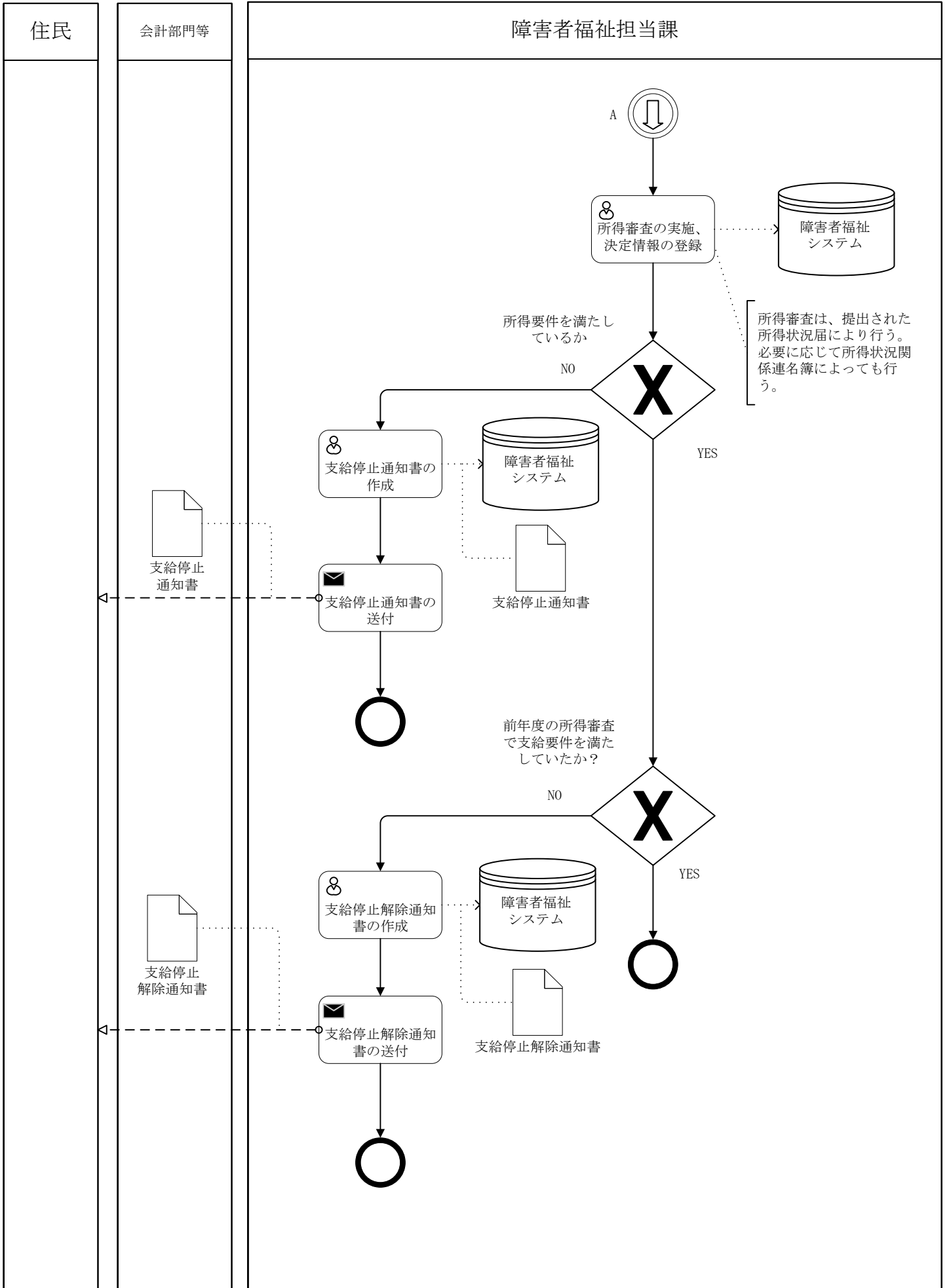

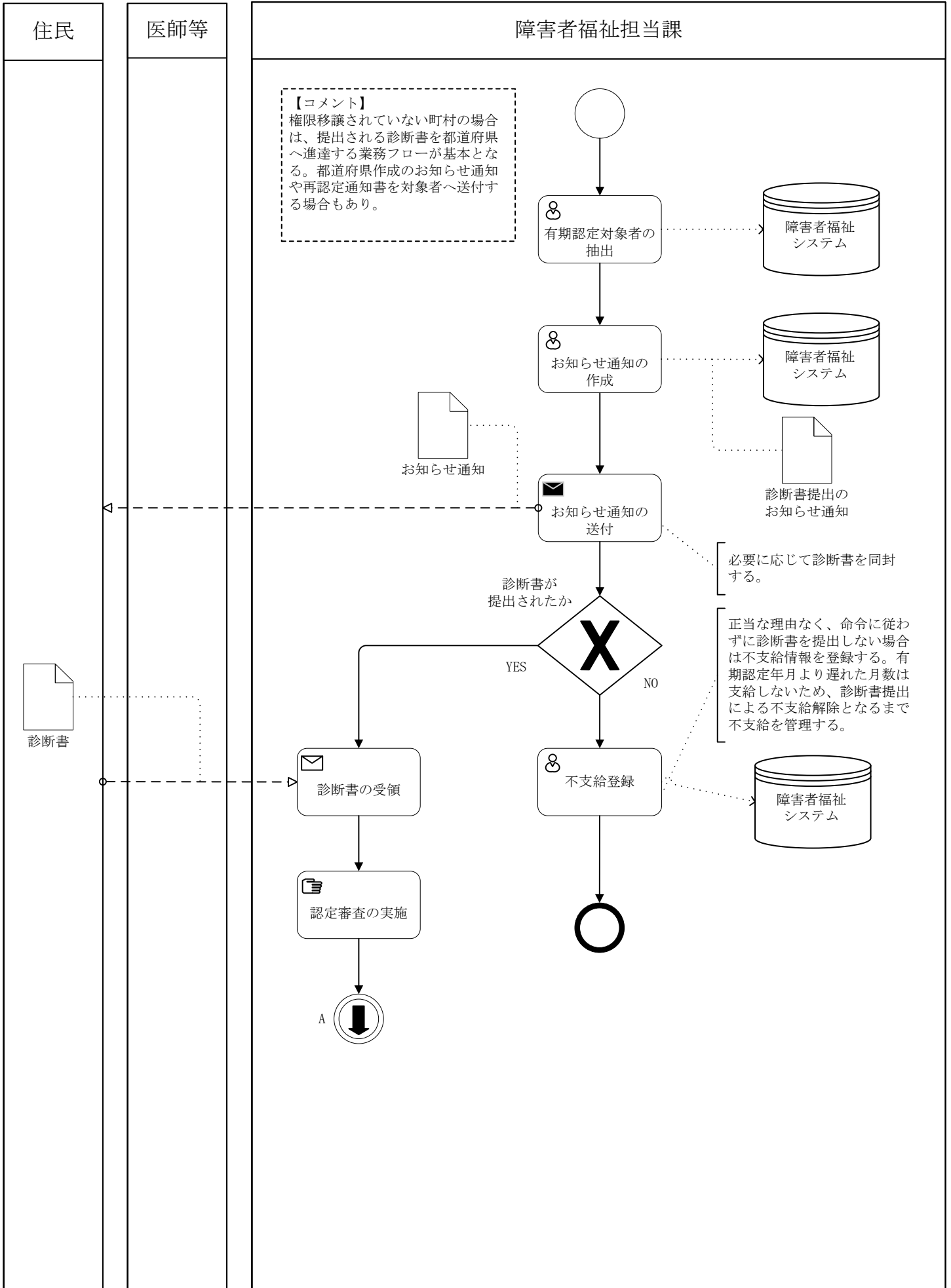



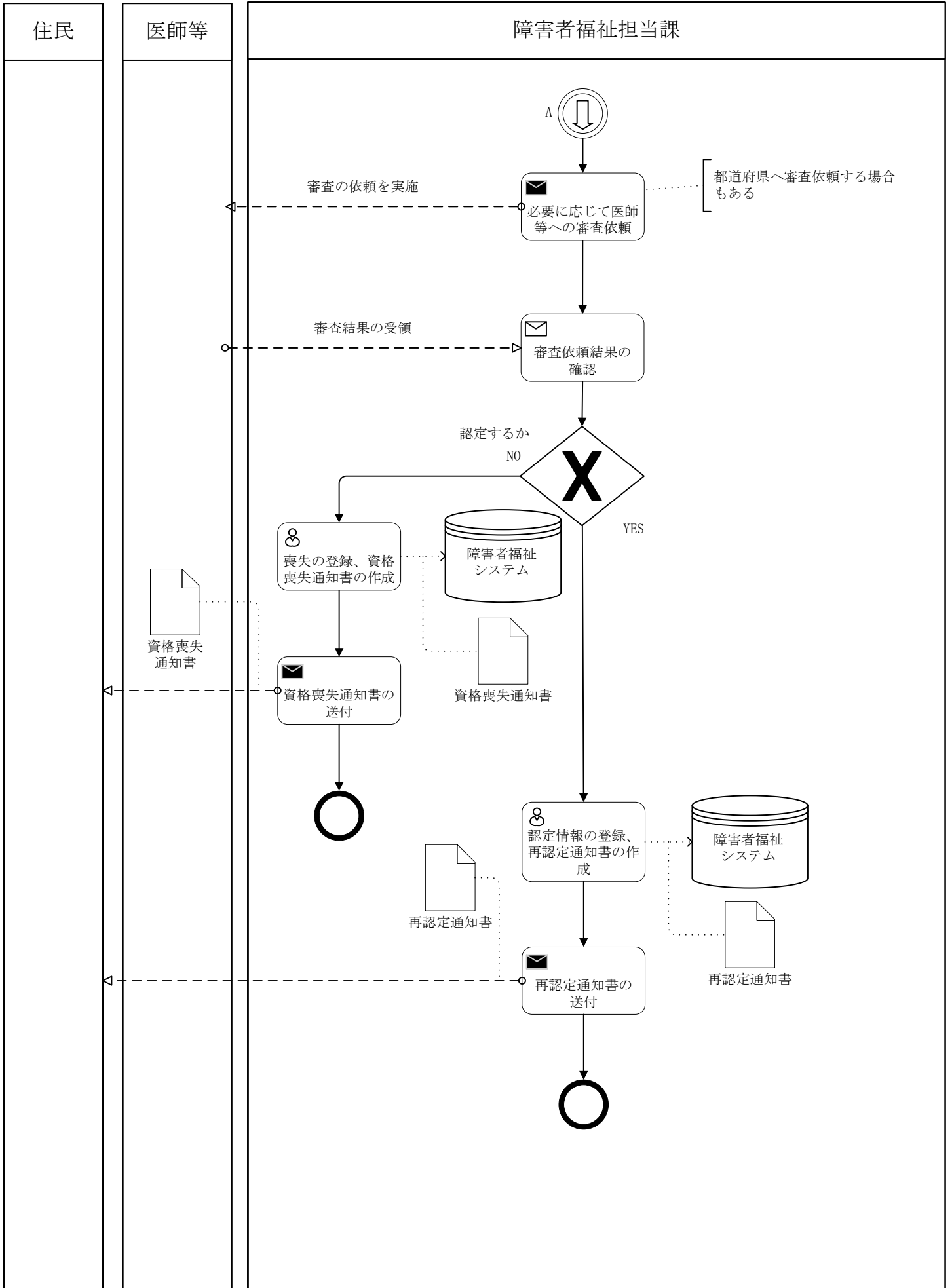

住民

会計部門等

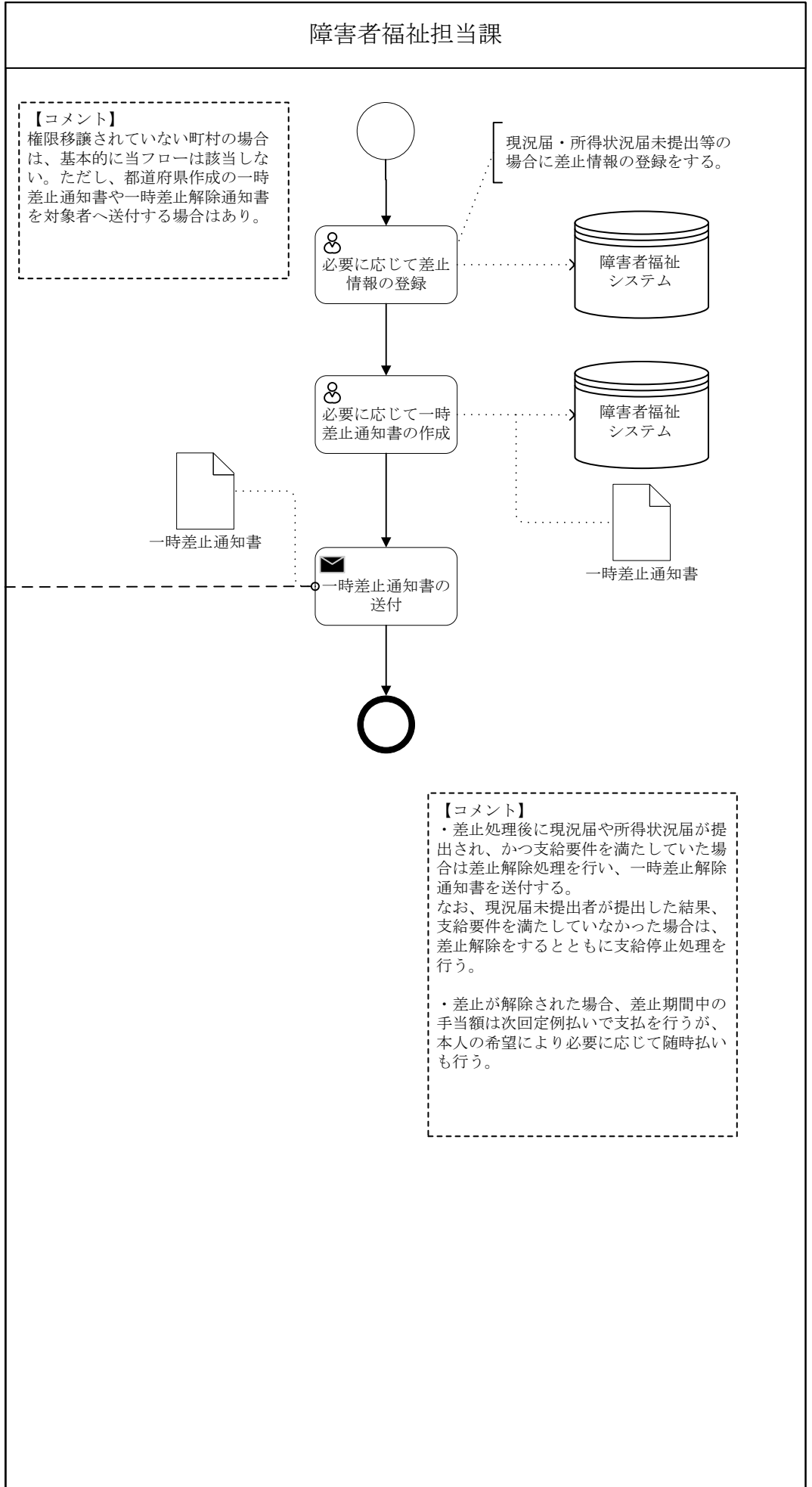

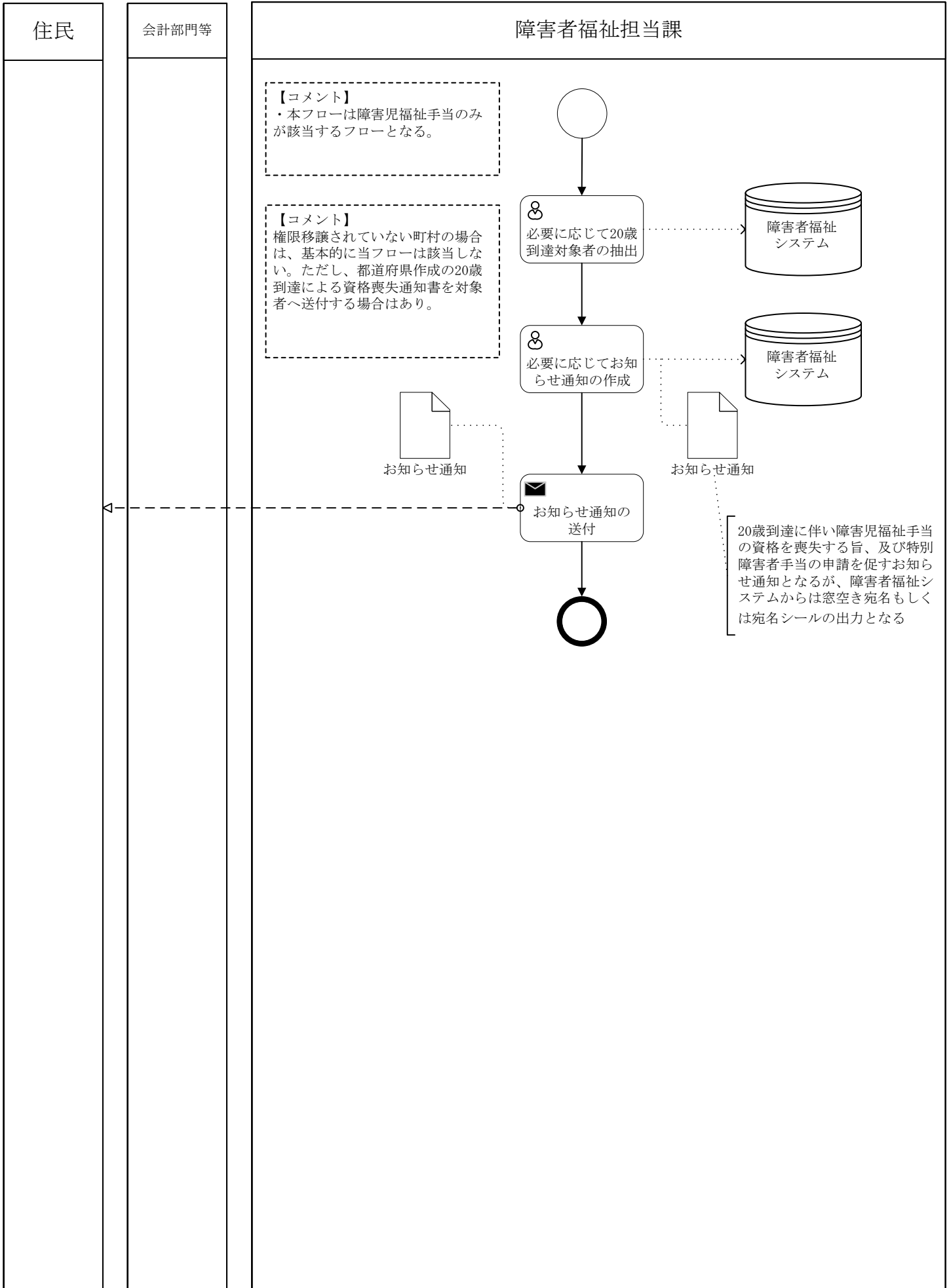

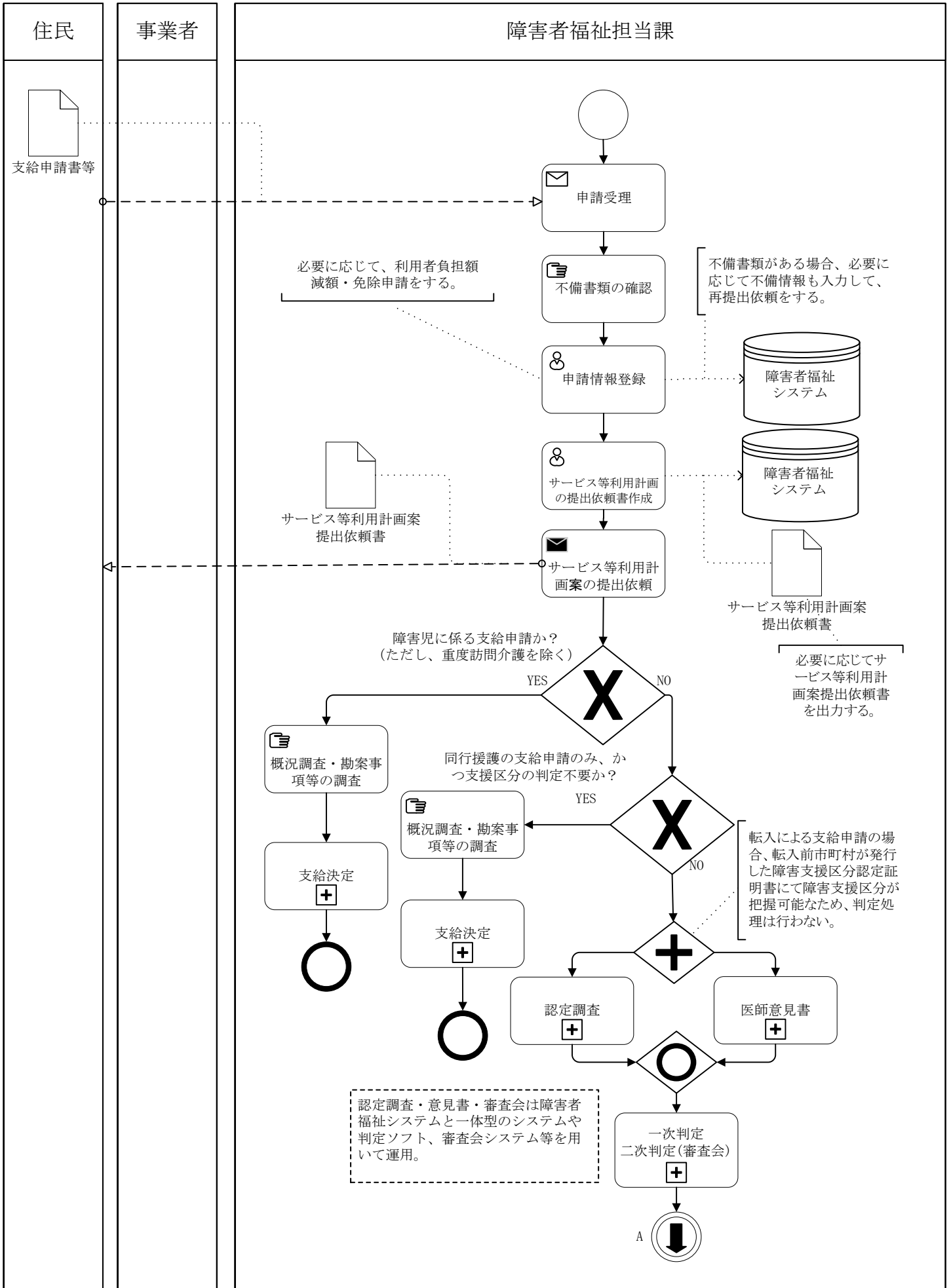

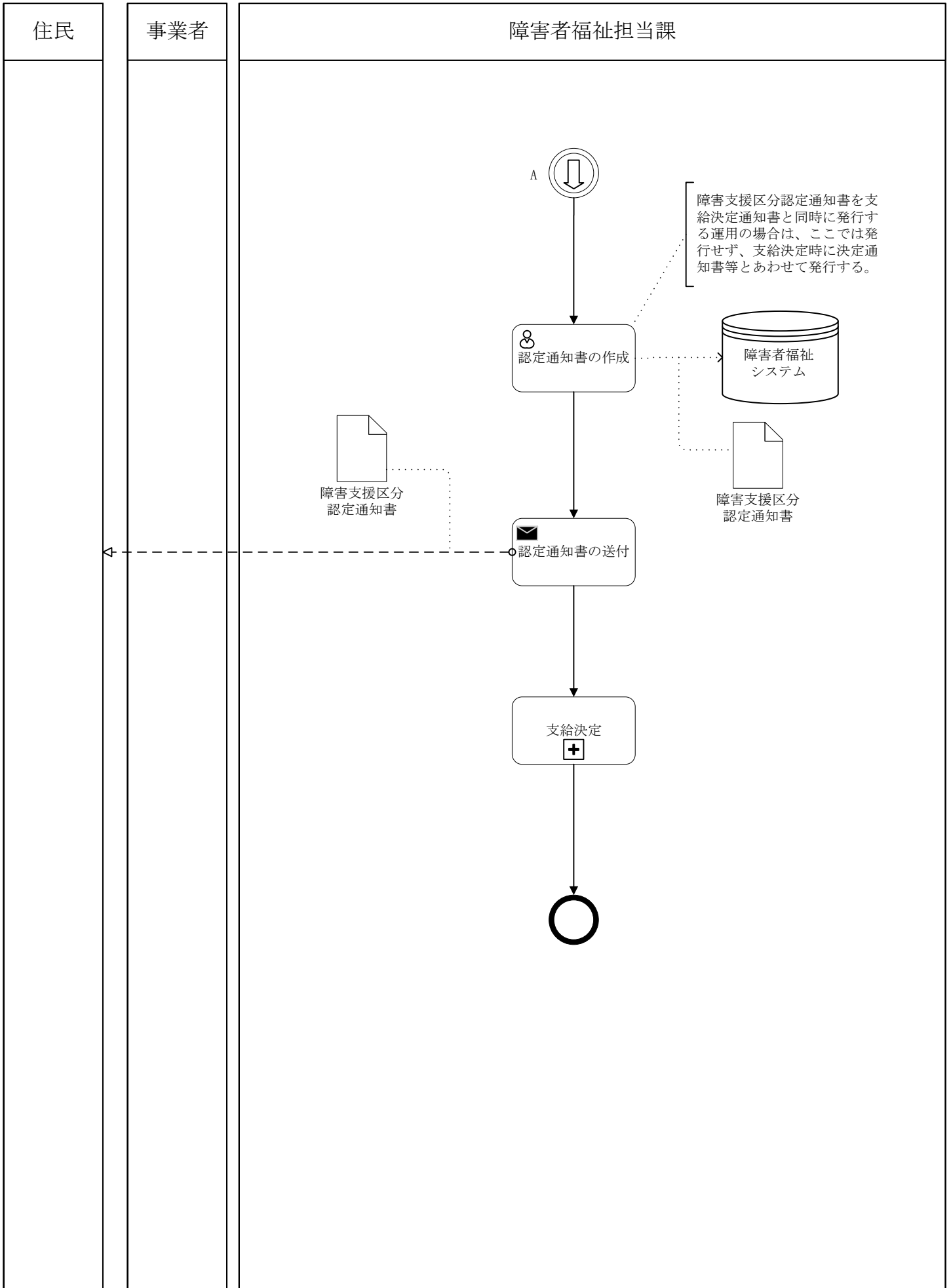

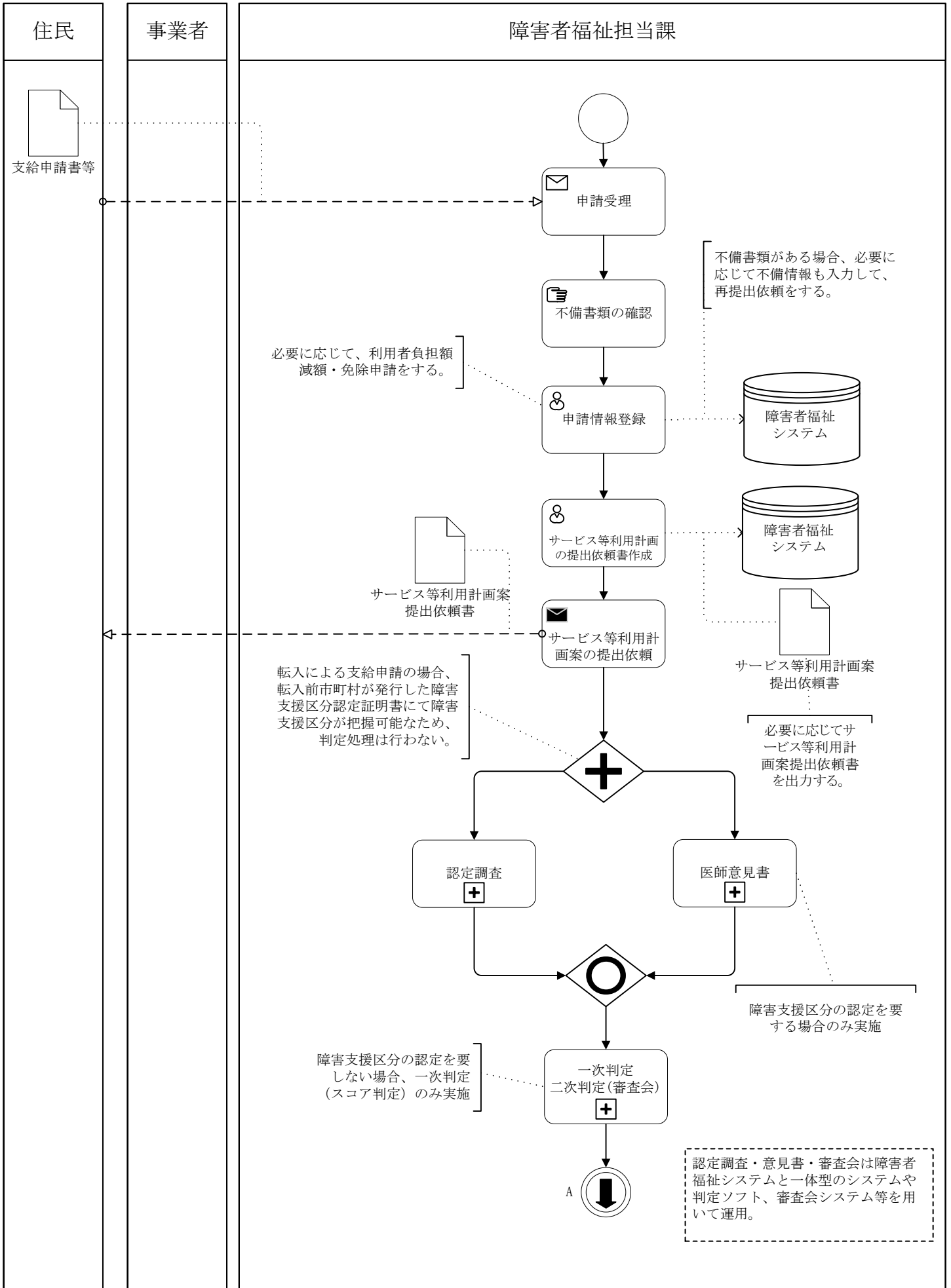

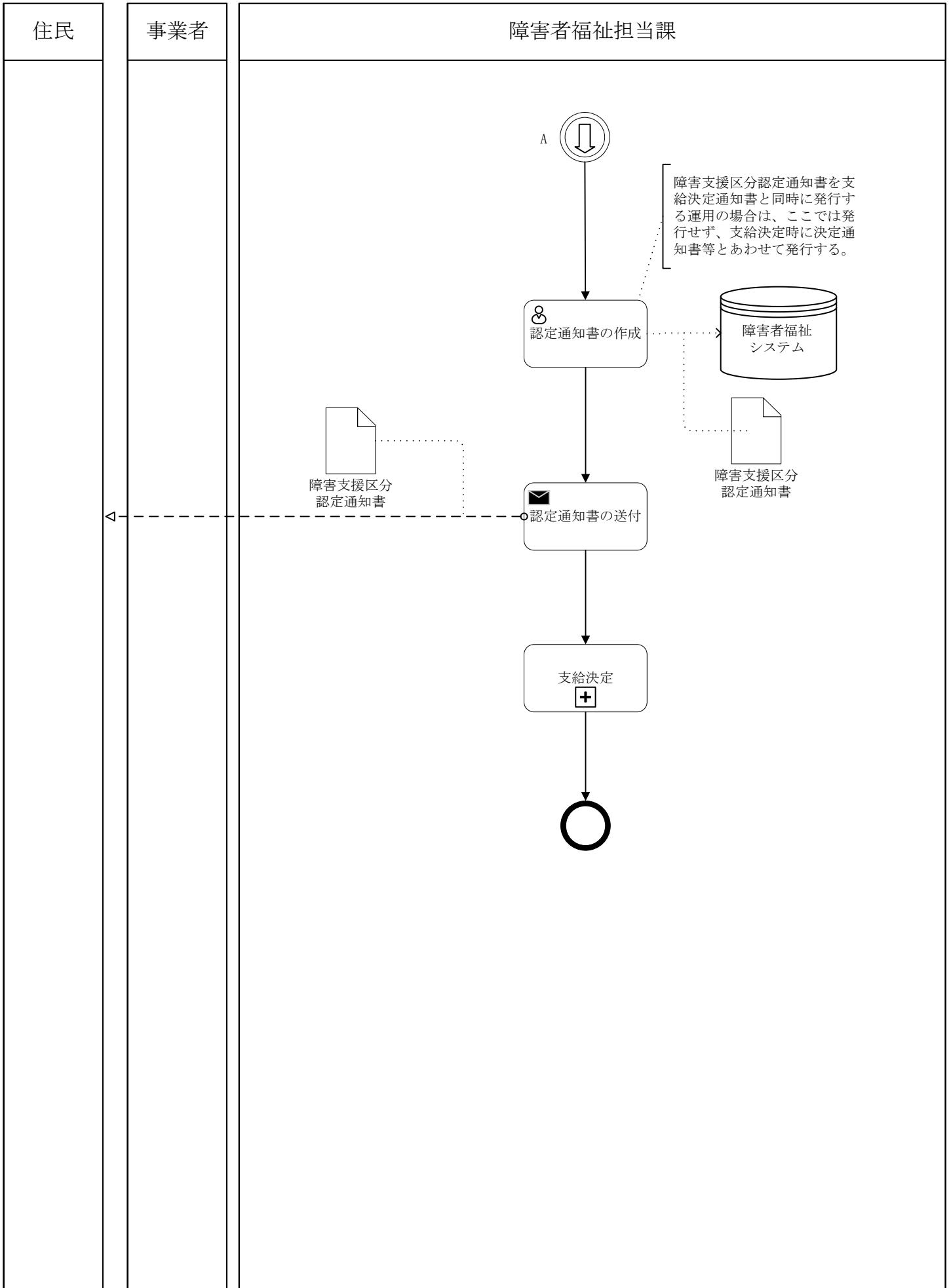

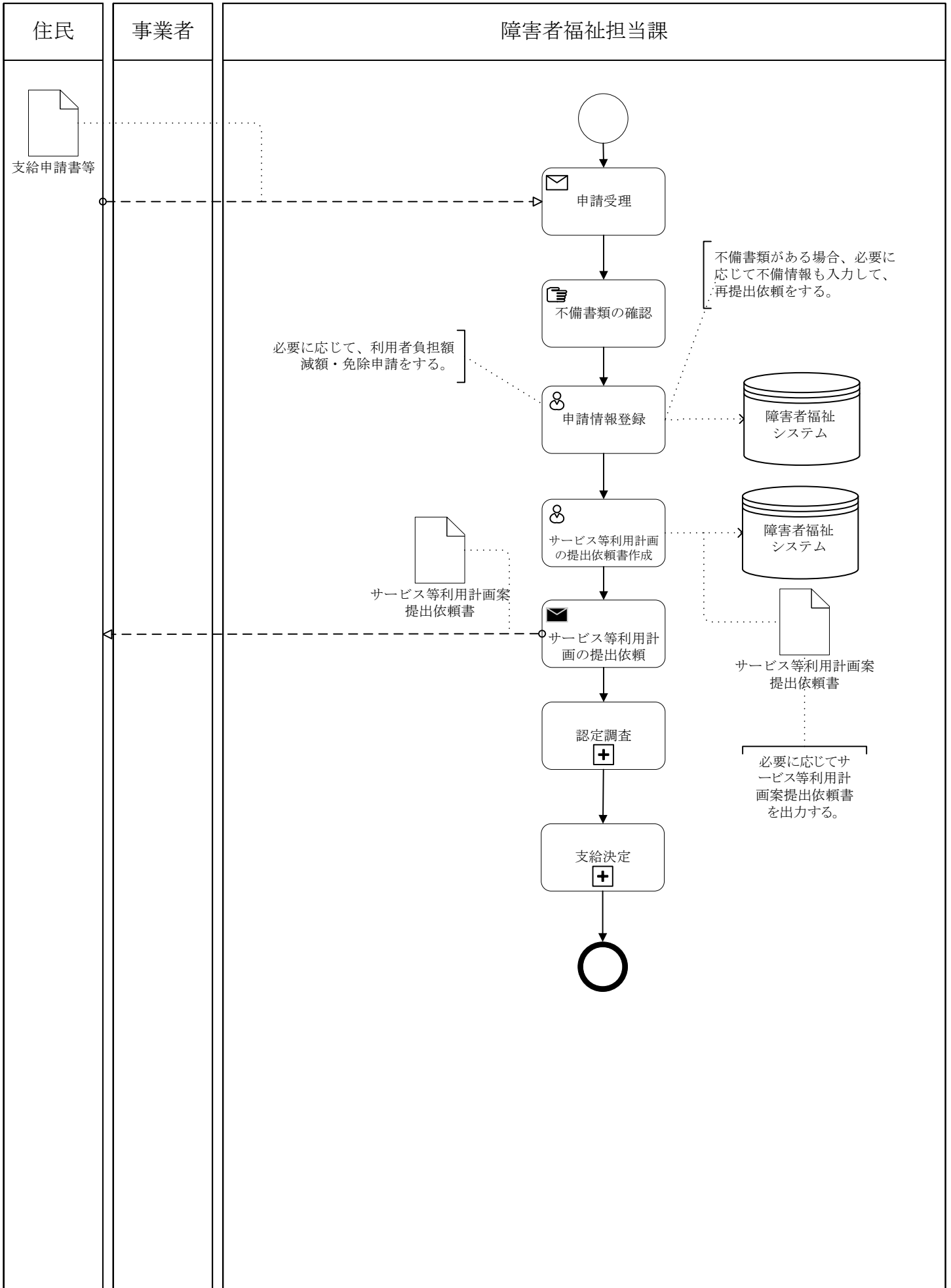



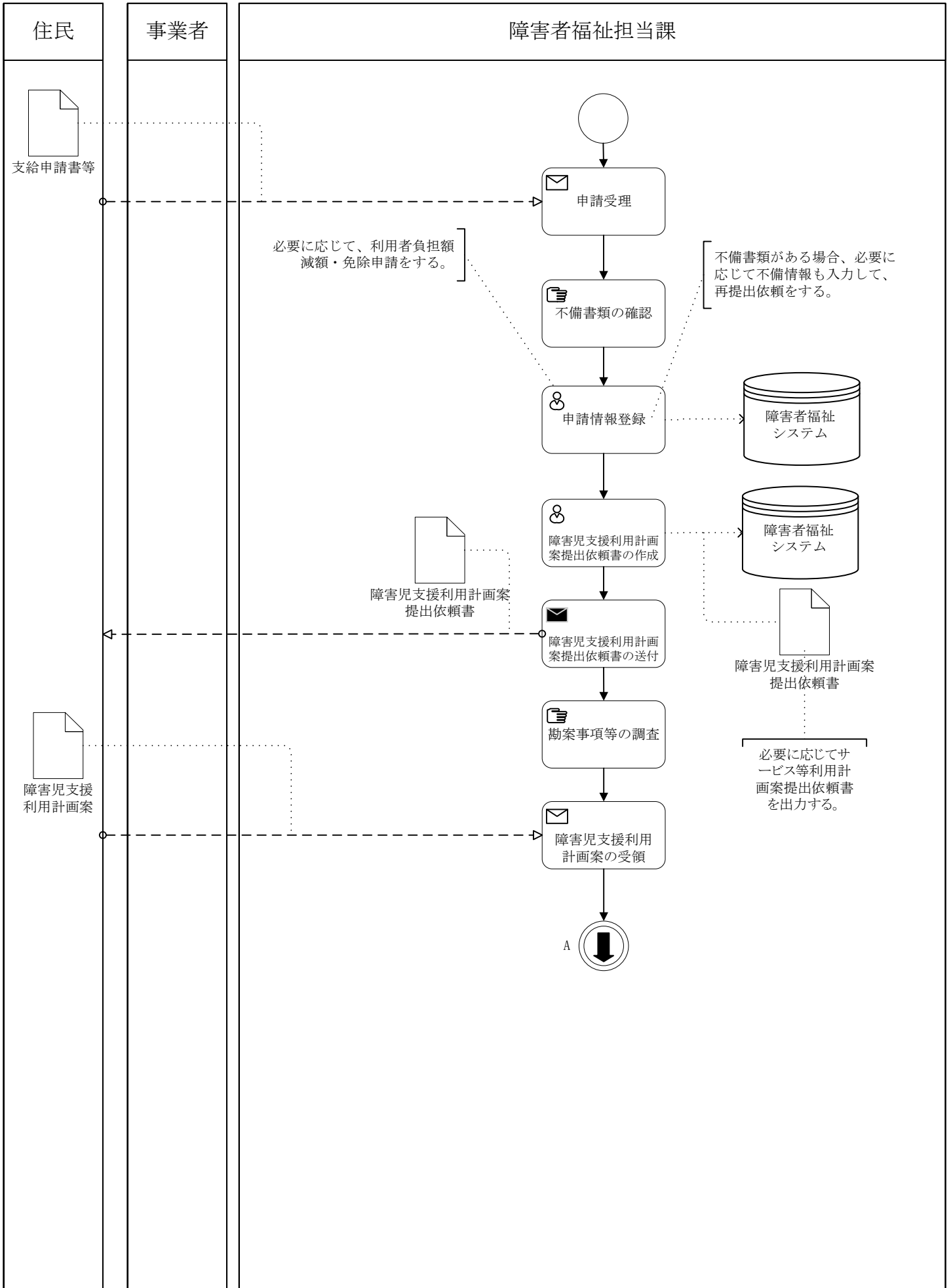

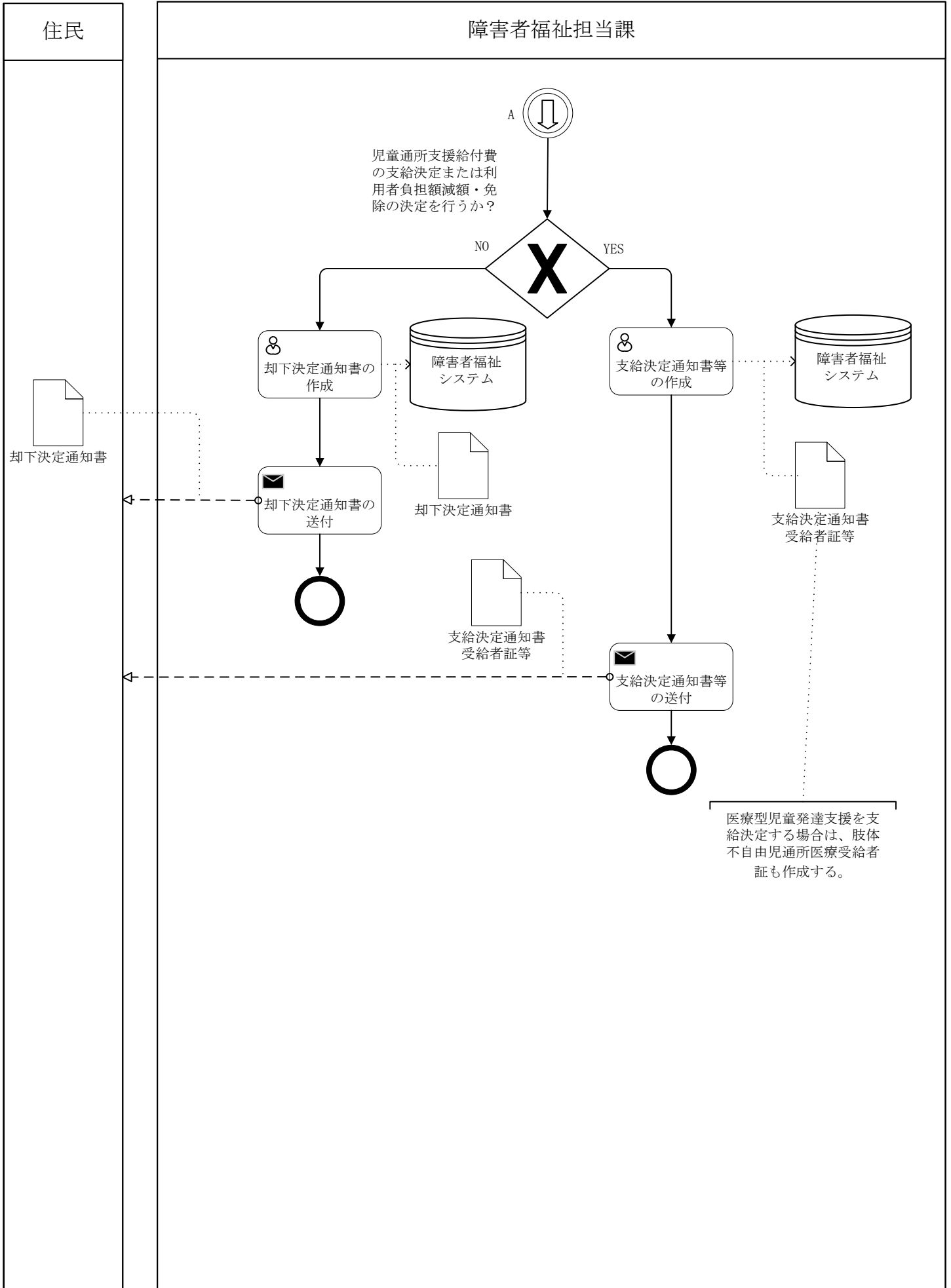

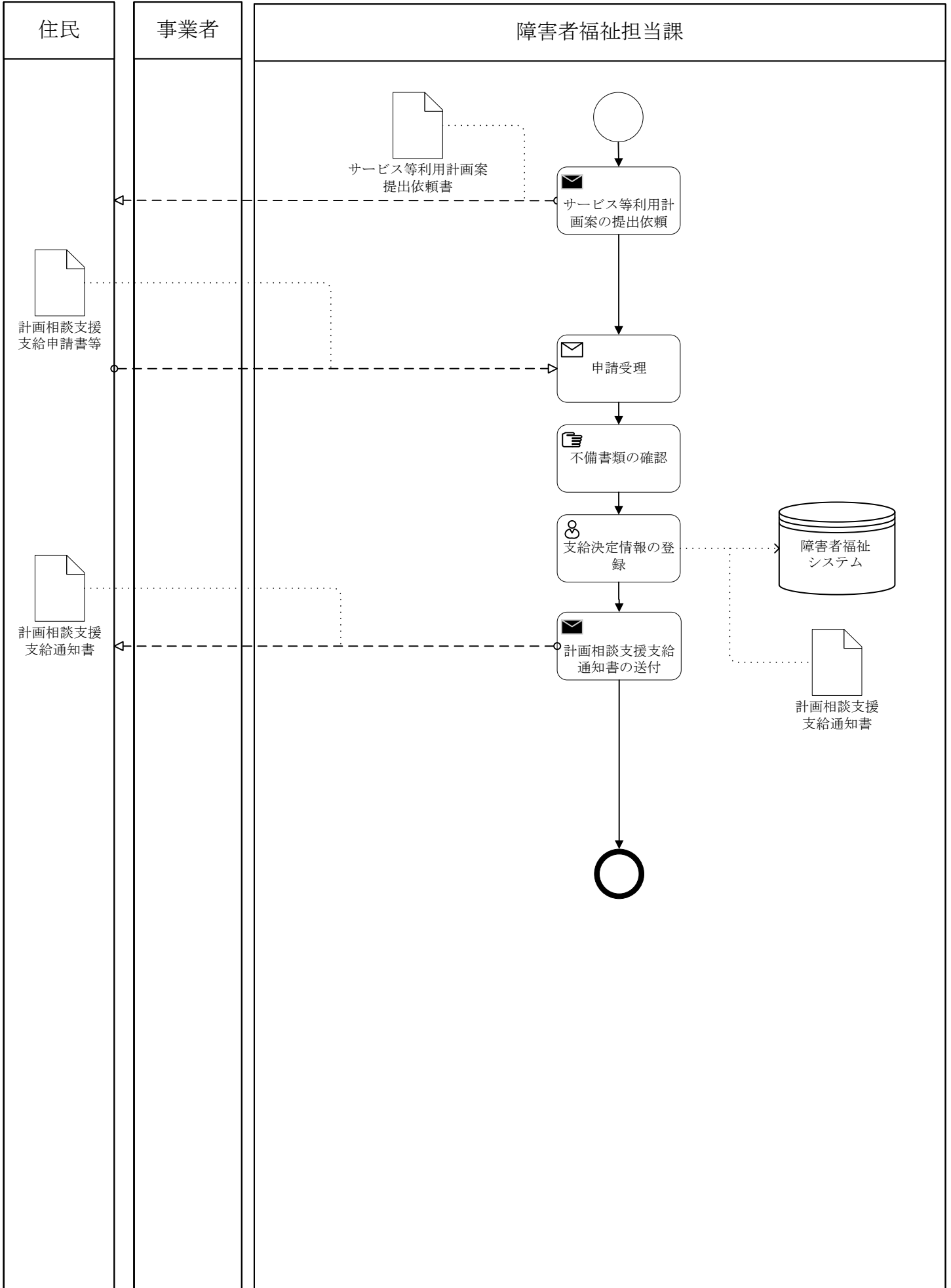

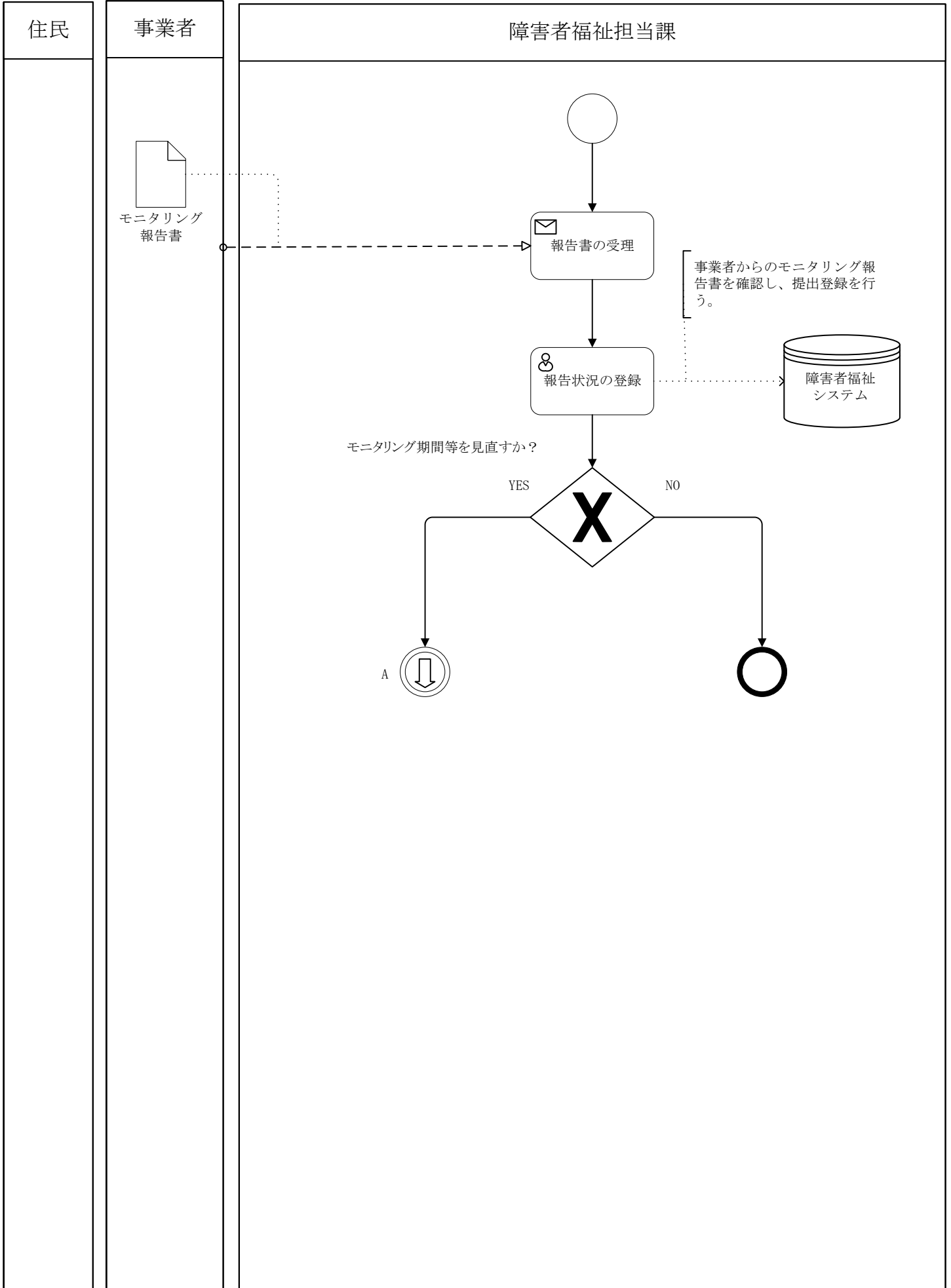

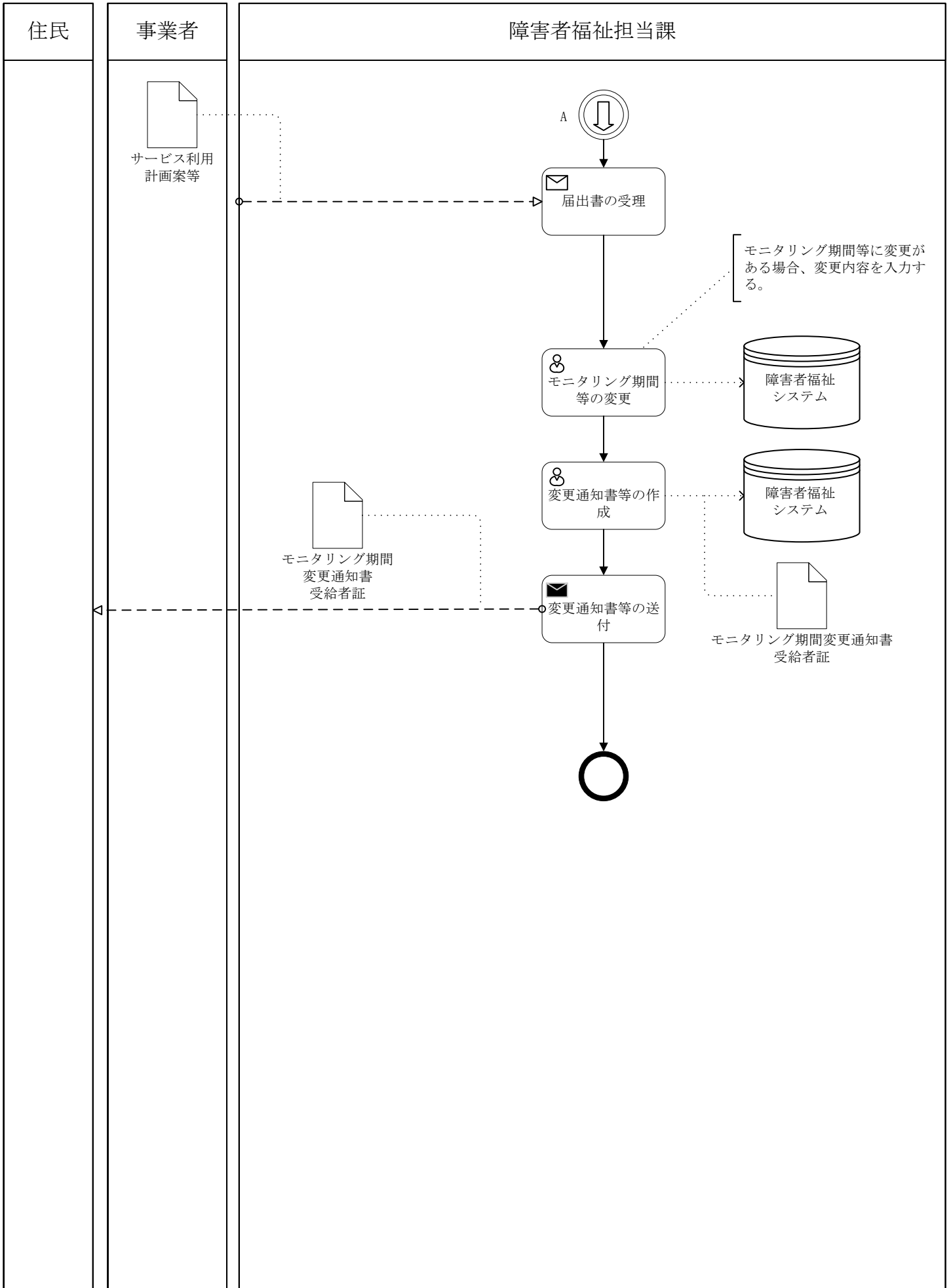

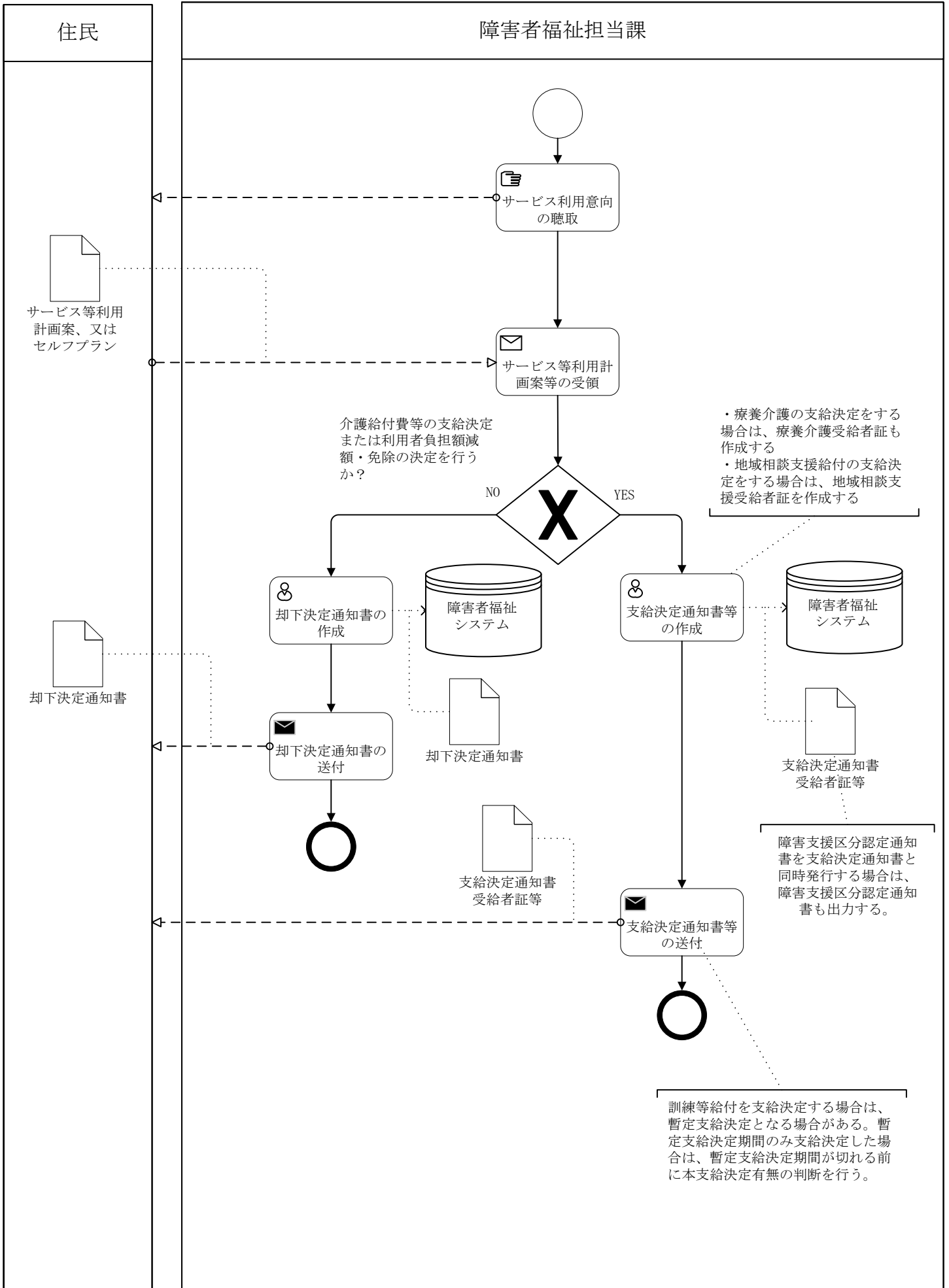

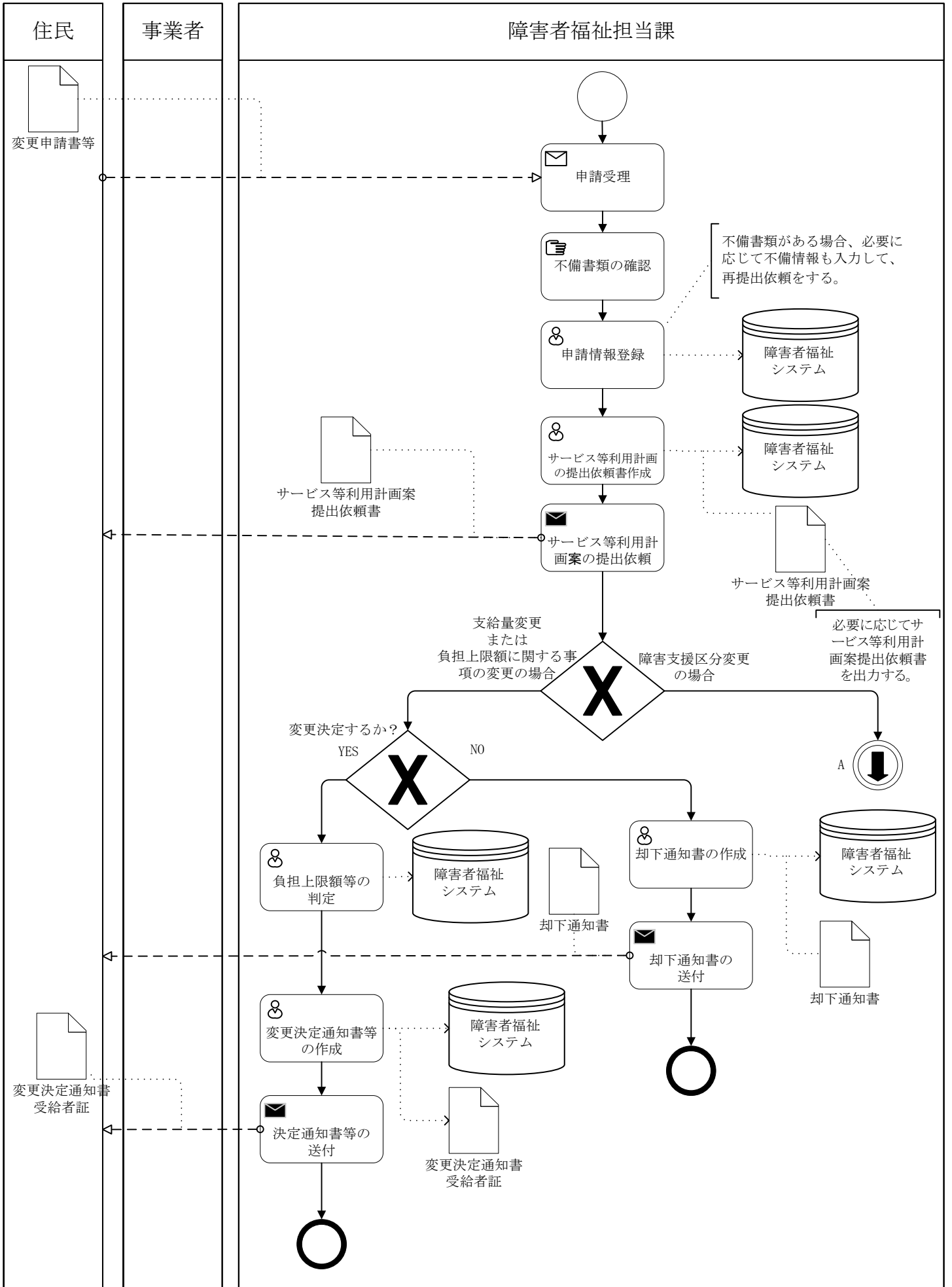

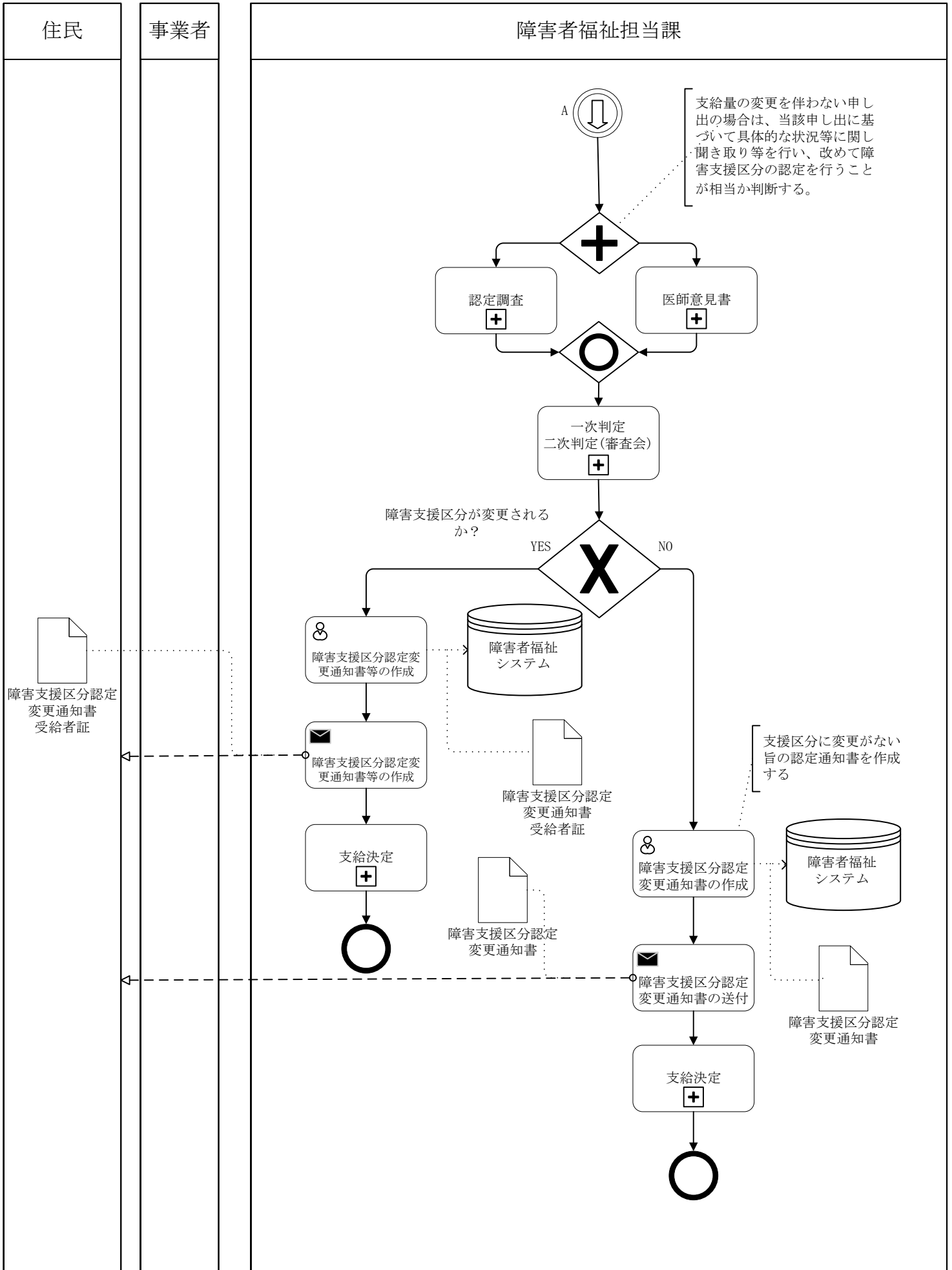



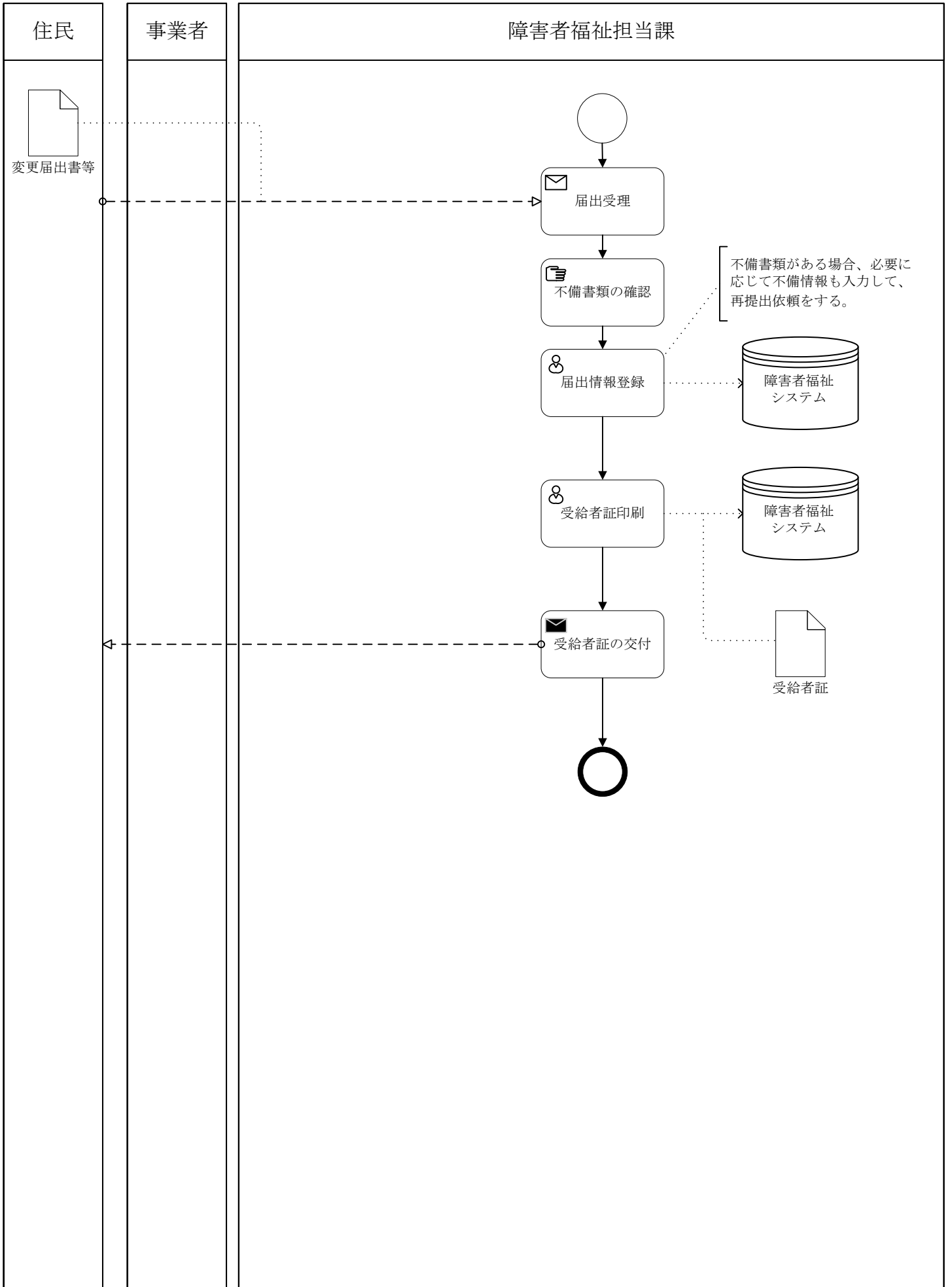



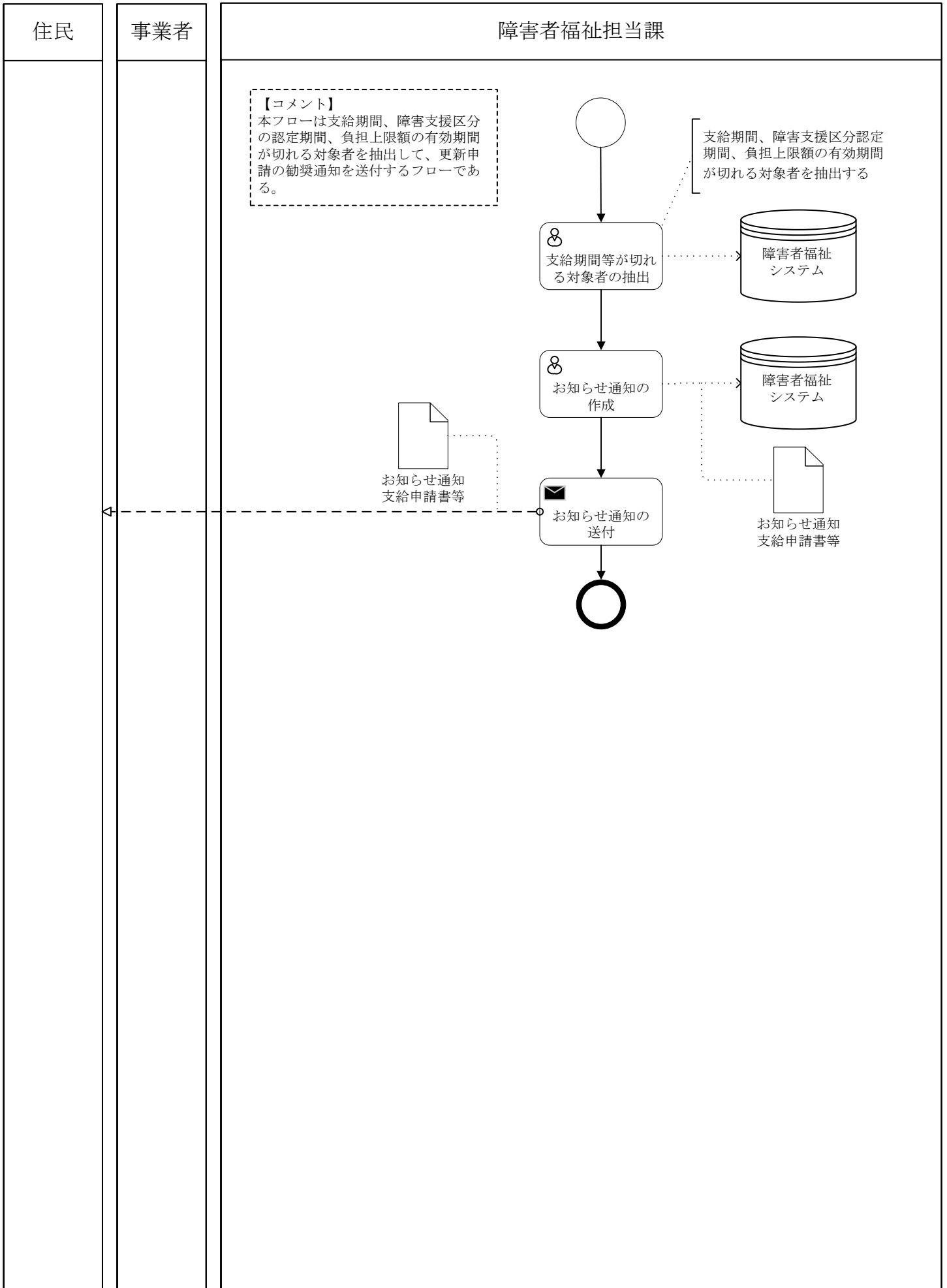

|    |         |     |              |     |         |
|----|---------|-----|--------------|-----|---------|
| 区分 | 1 障害者福祉 | 大分類 | 06 障害福祉サービス等 | 小分類 | 12 年齢到達 |
|----|---------|-----|--------------|-----|---------|

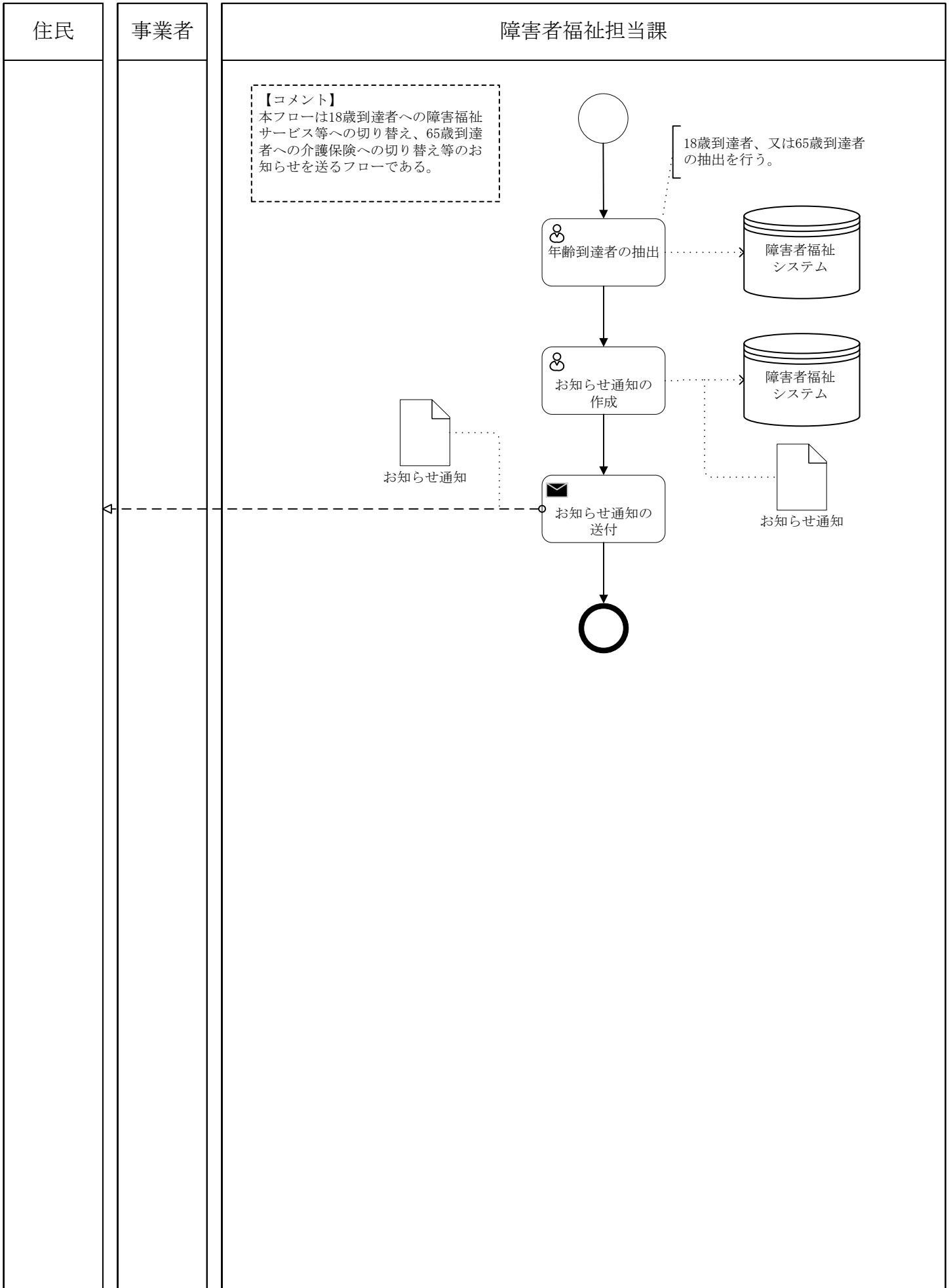

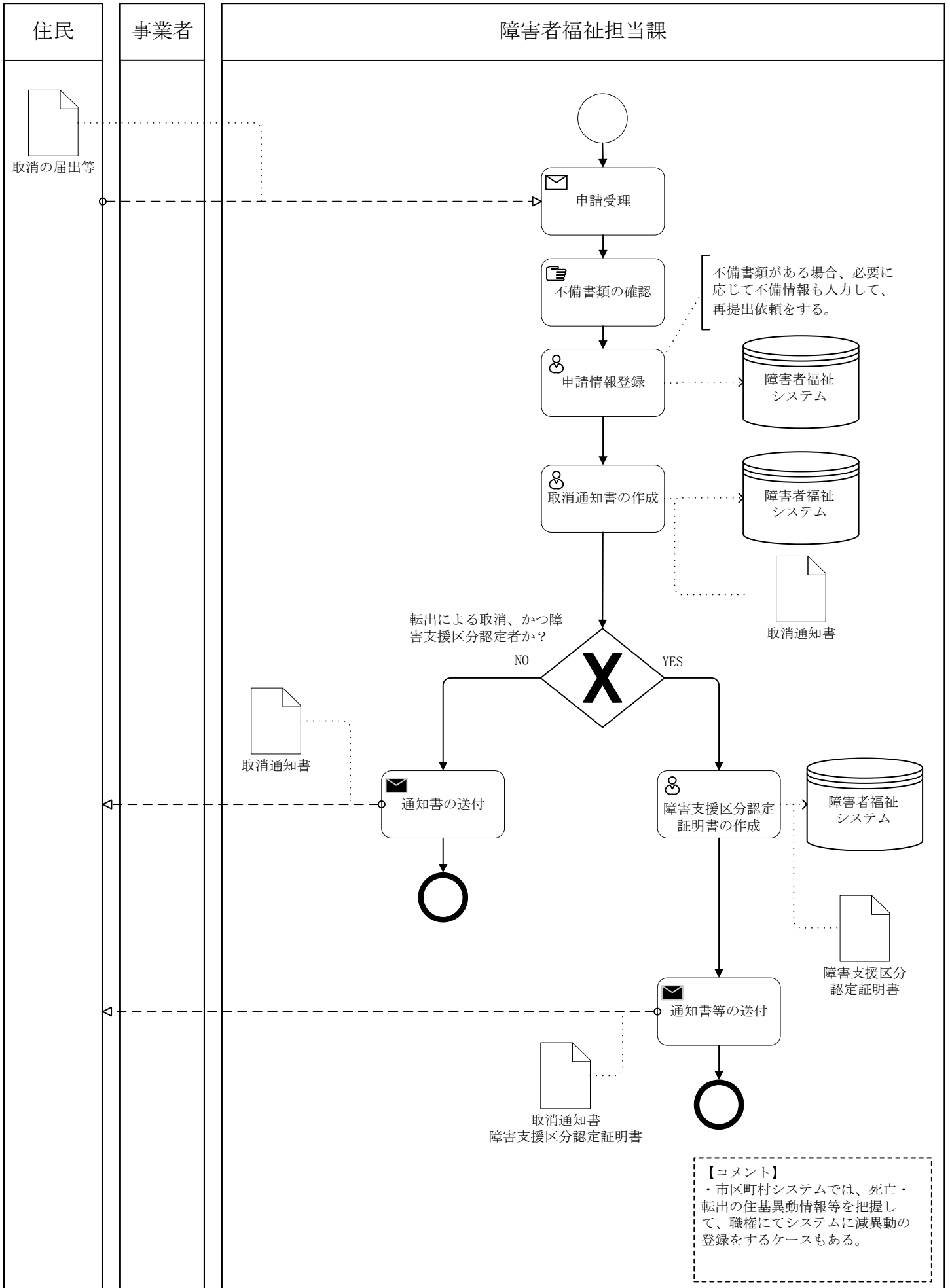

国保連合会

障害者福祉担当課

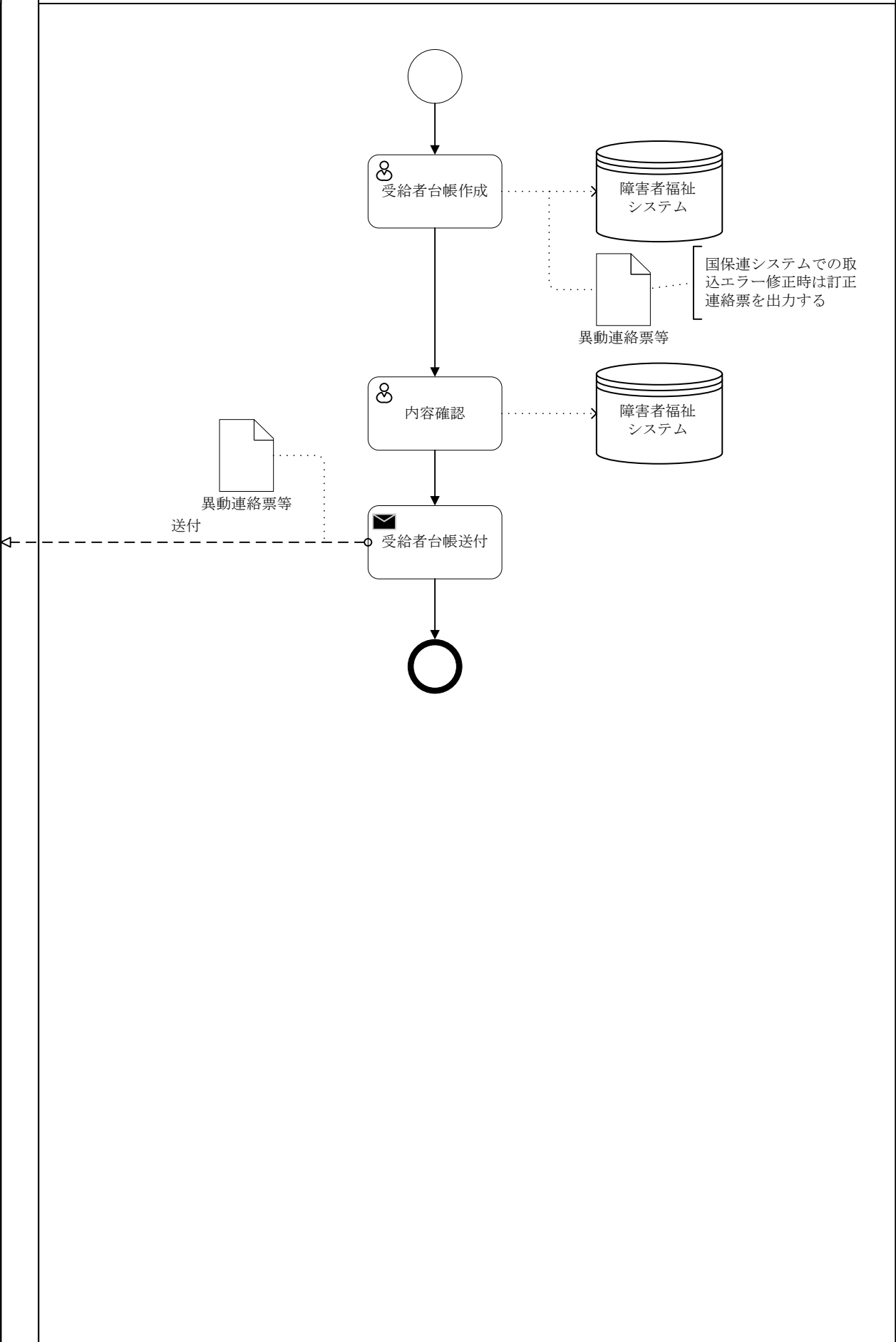



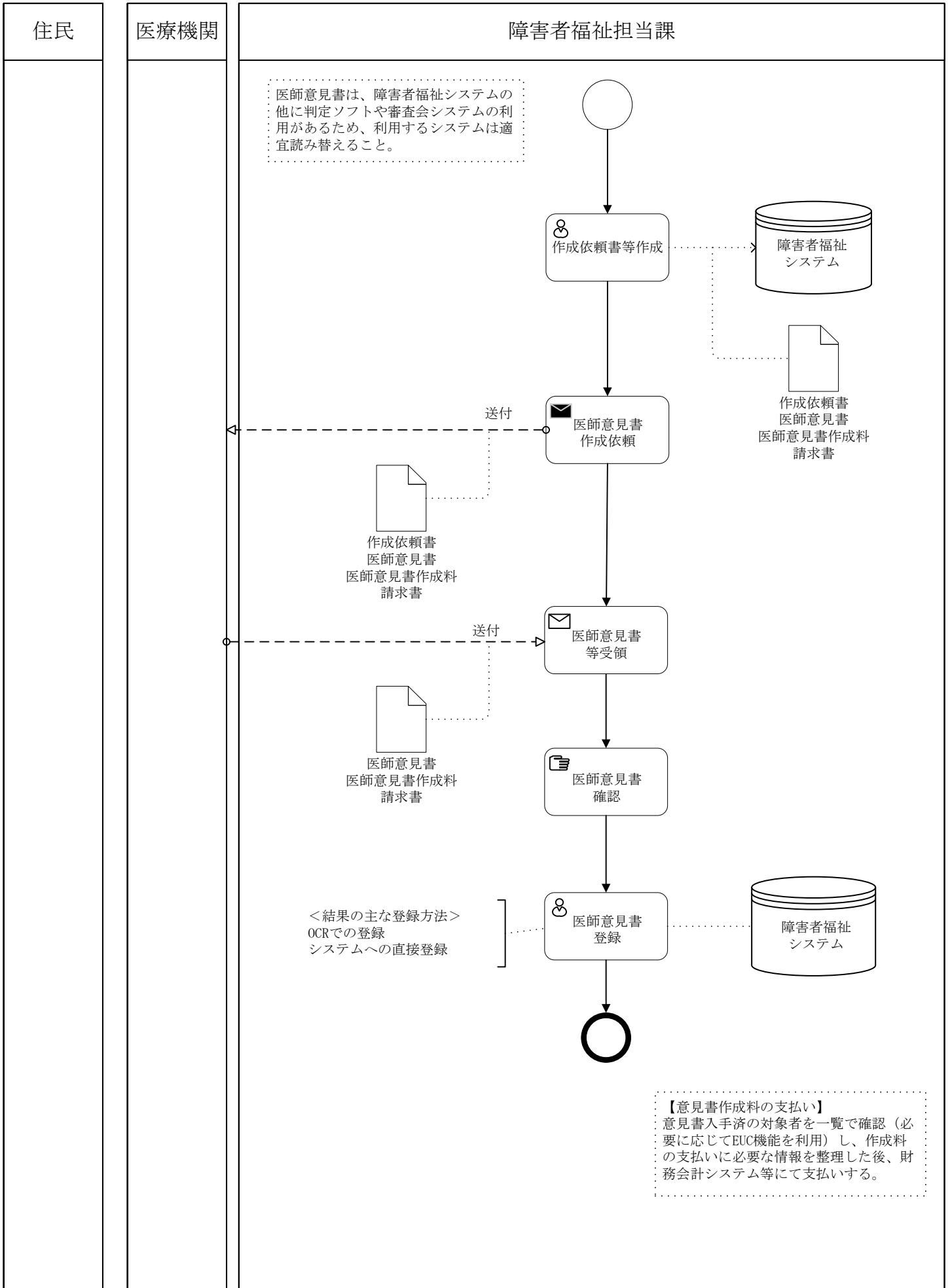





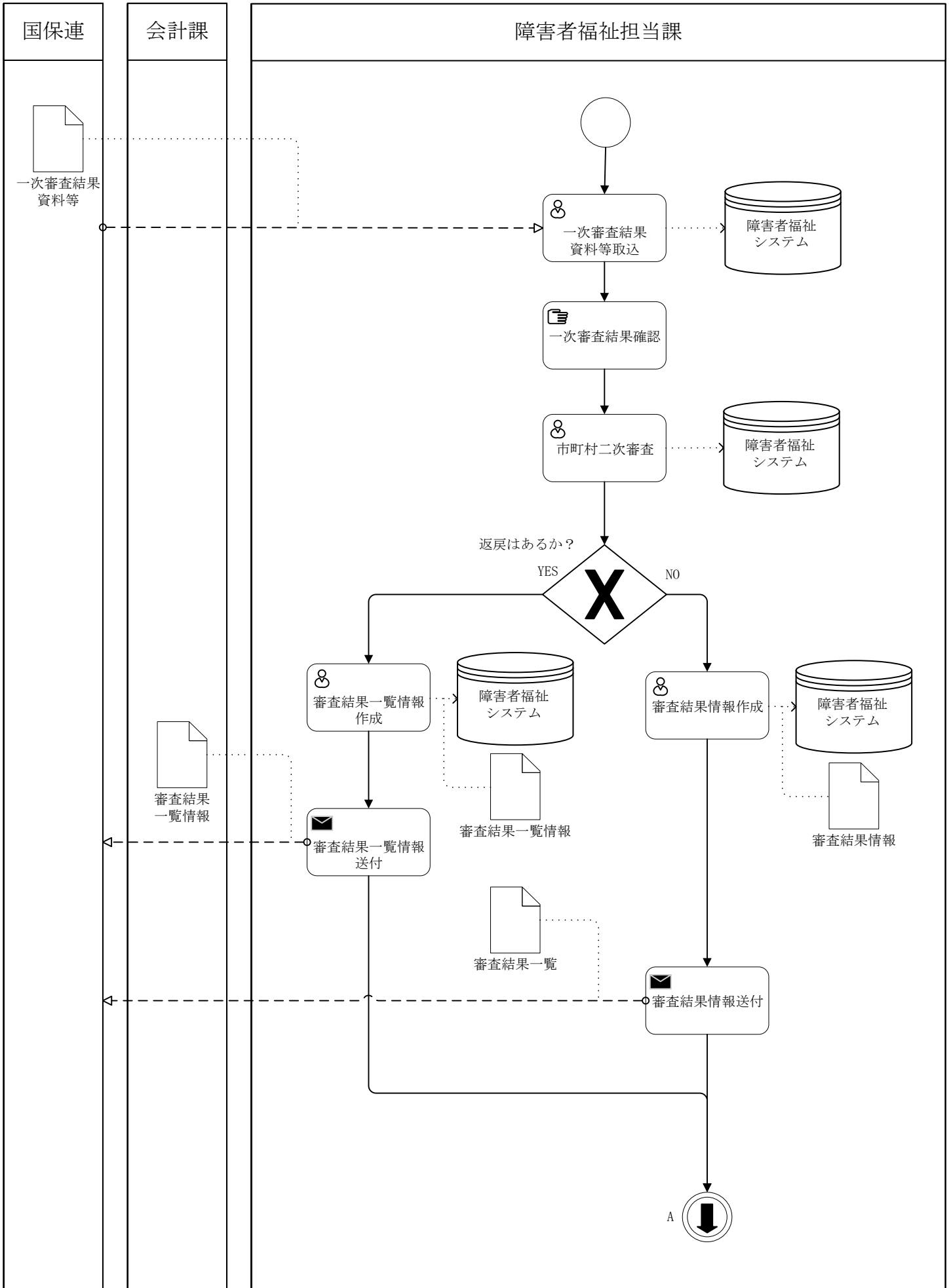

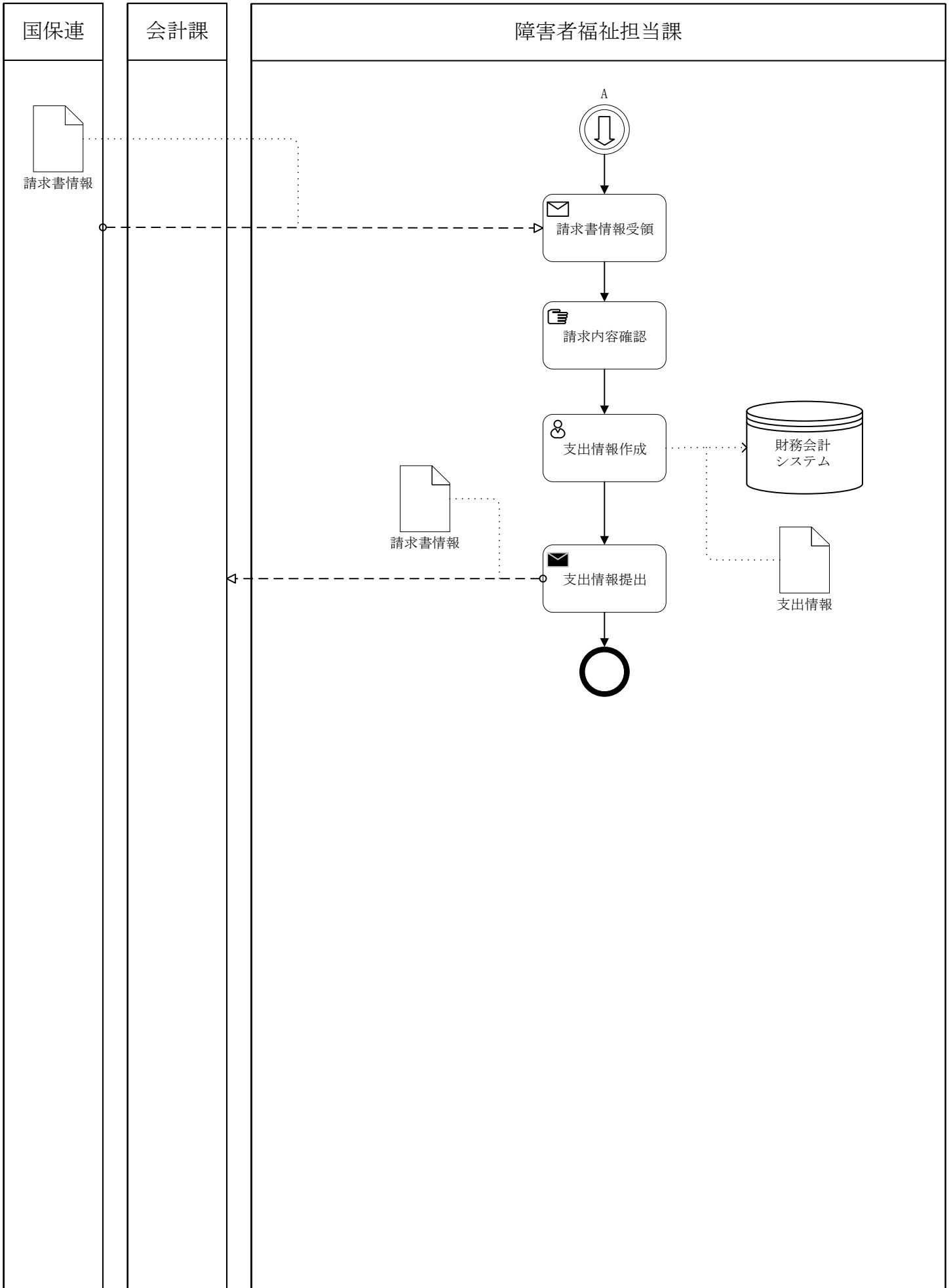

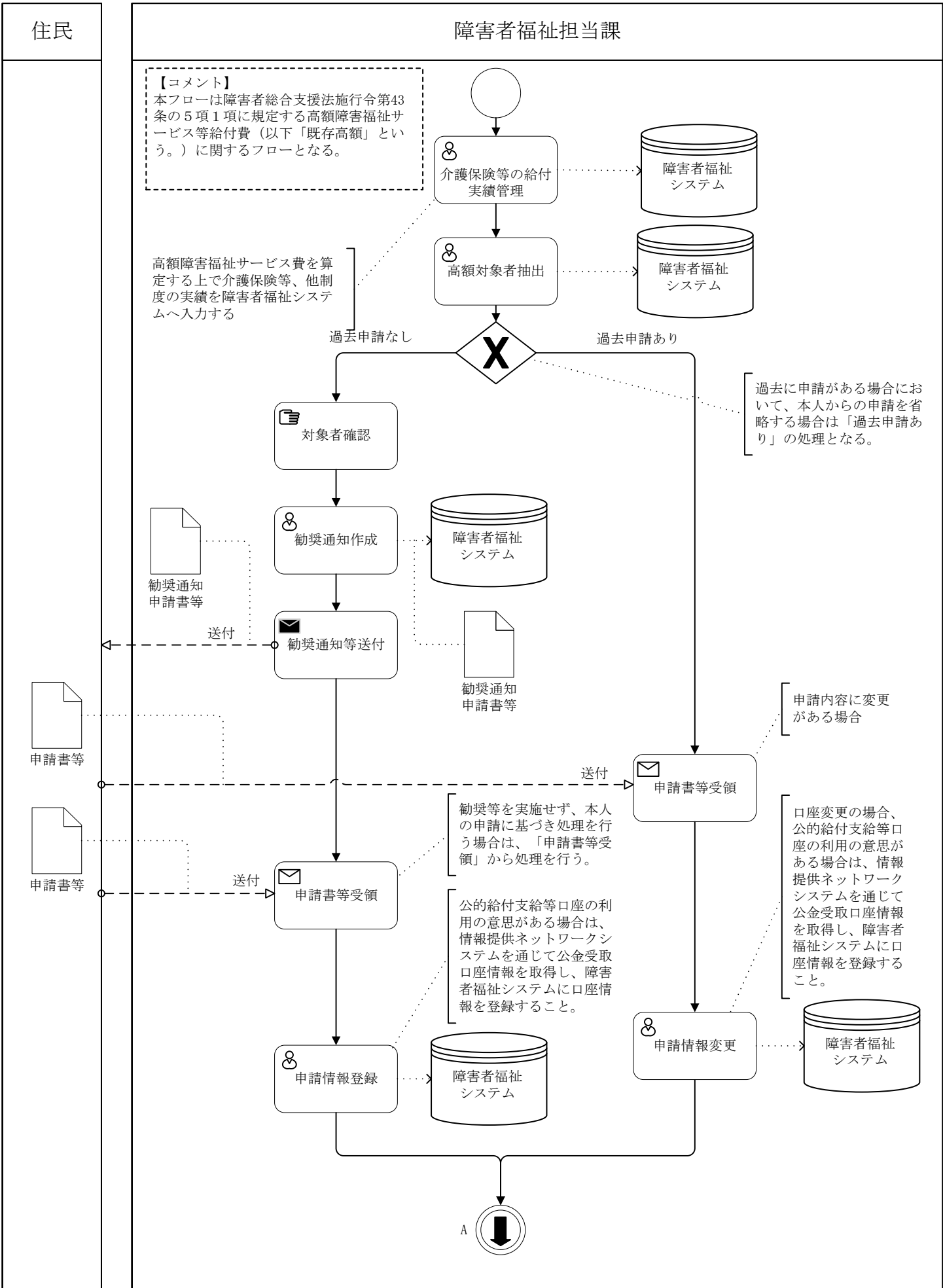

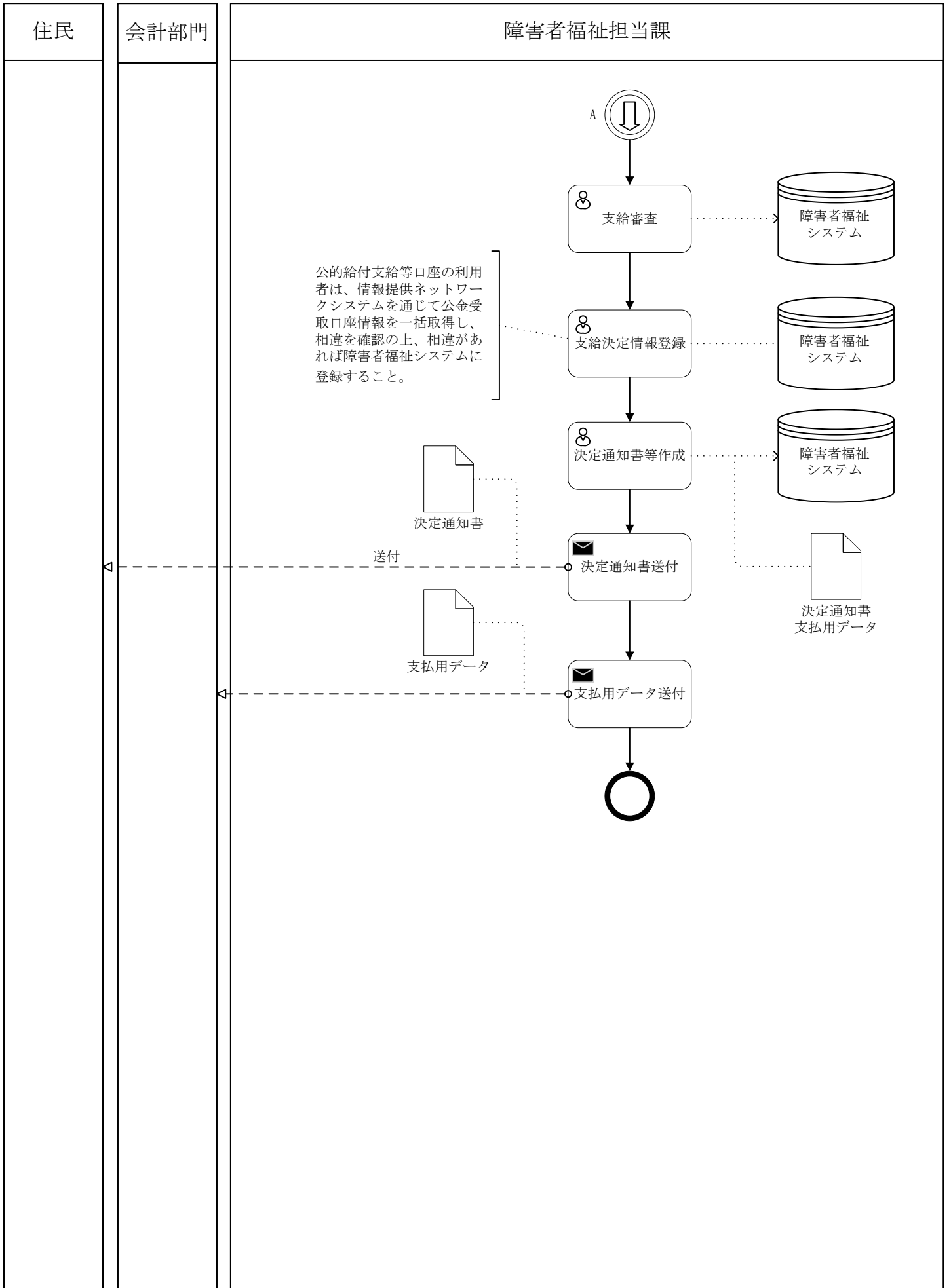

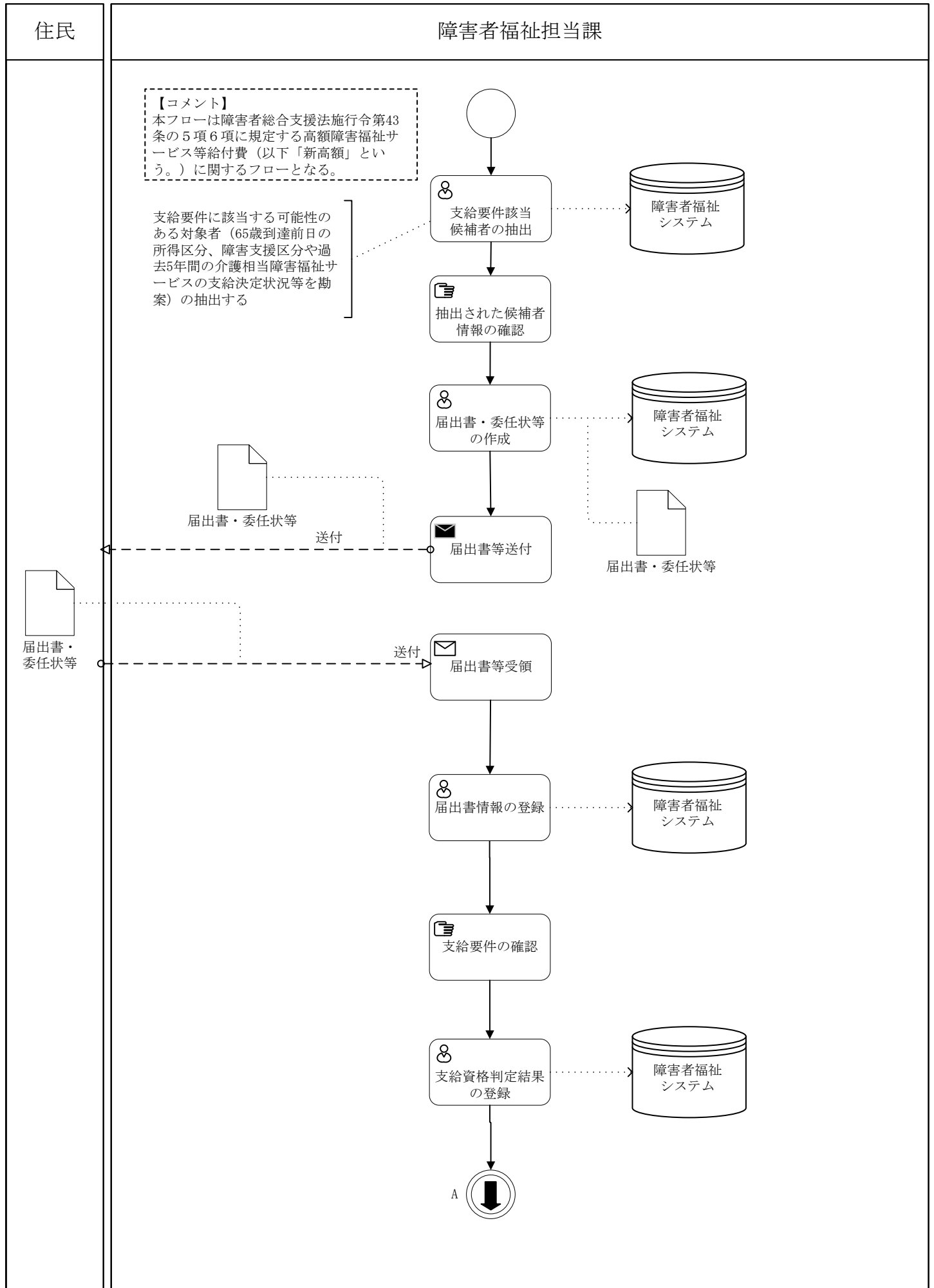



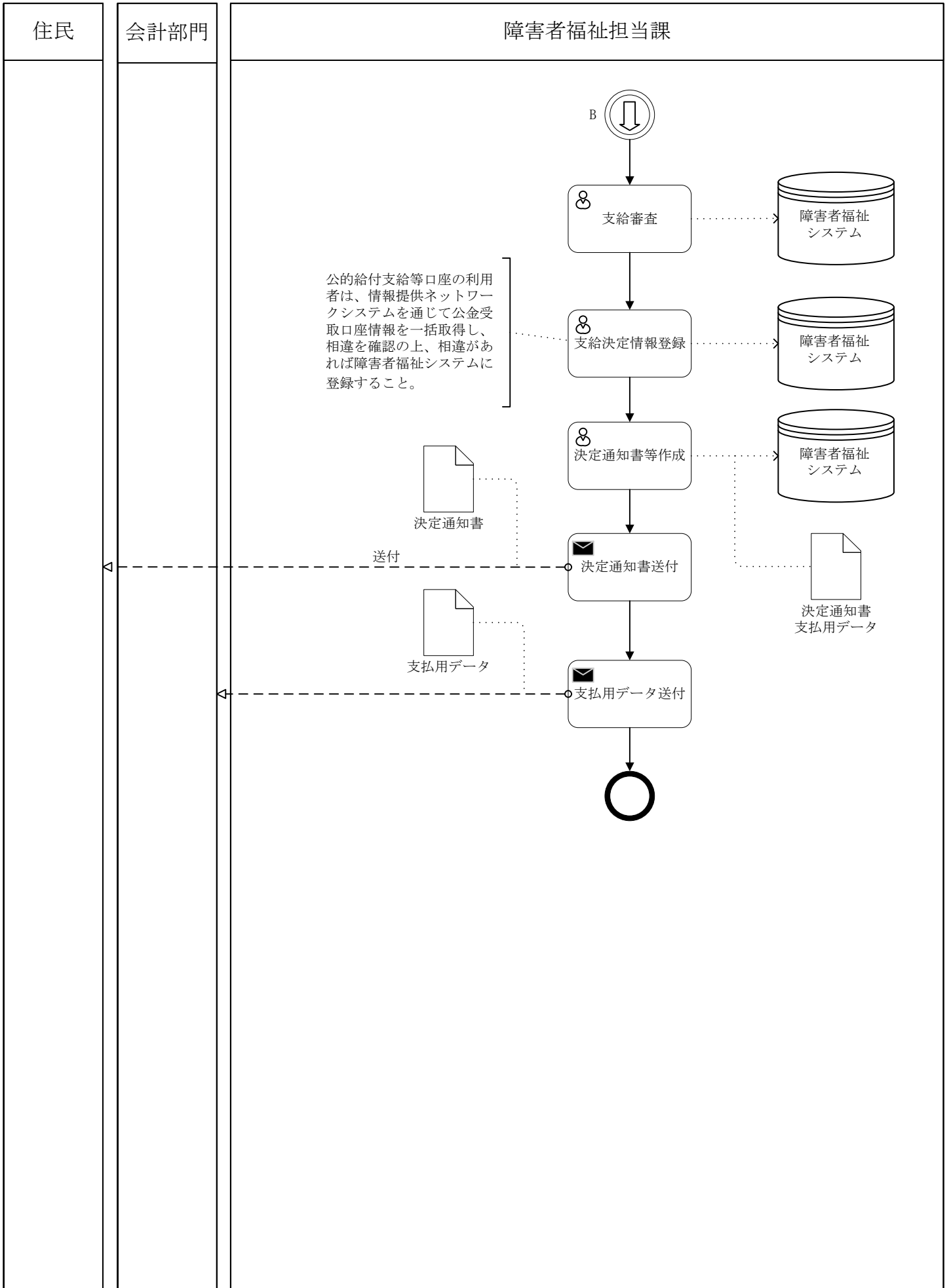



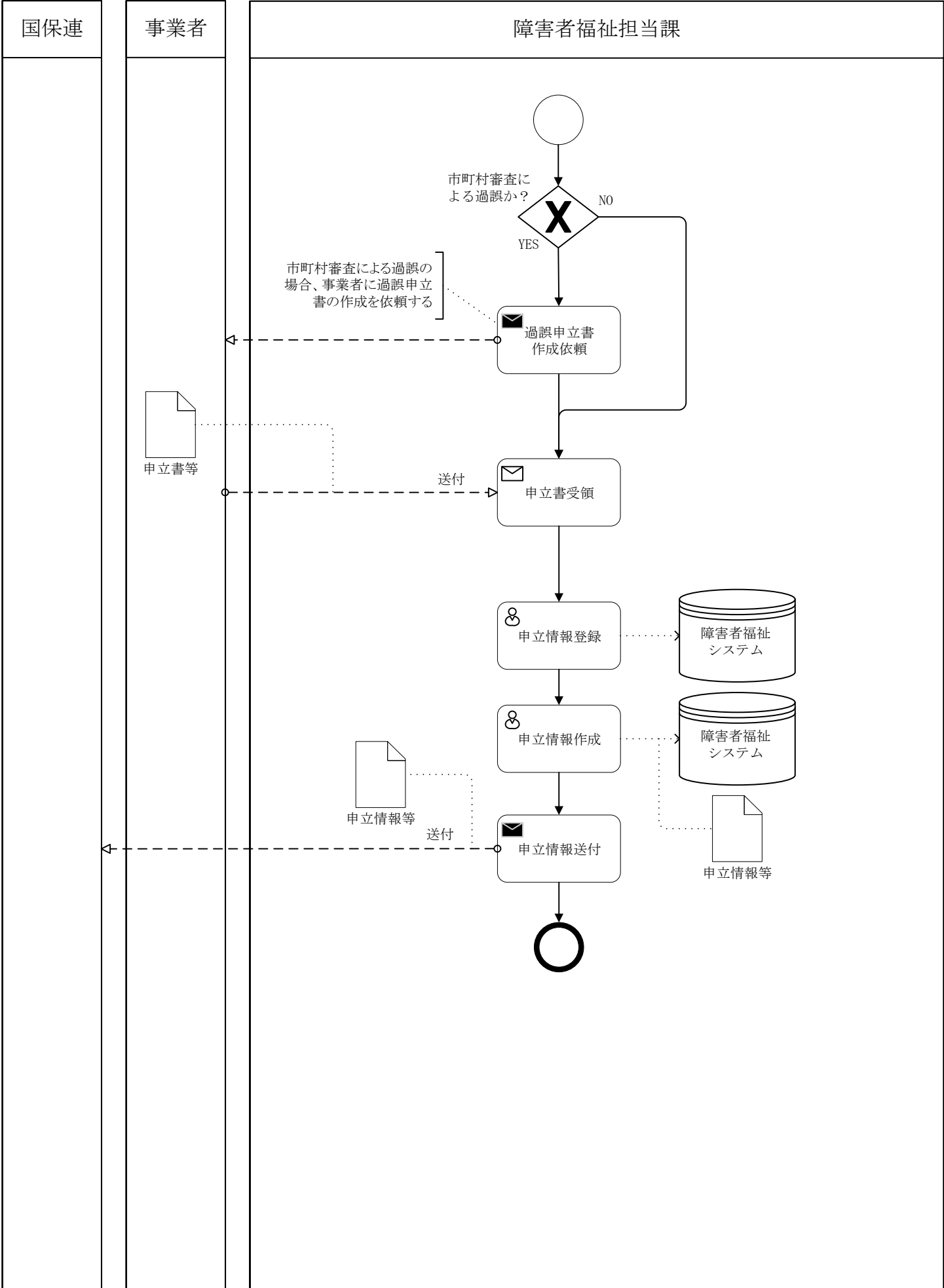

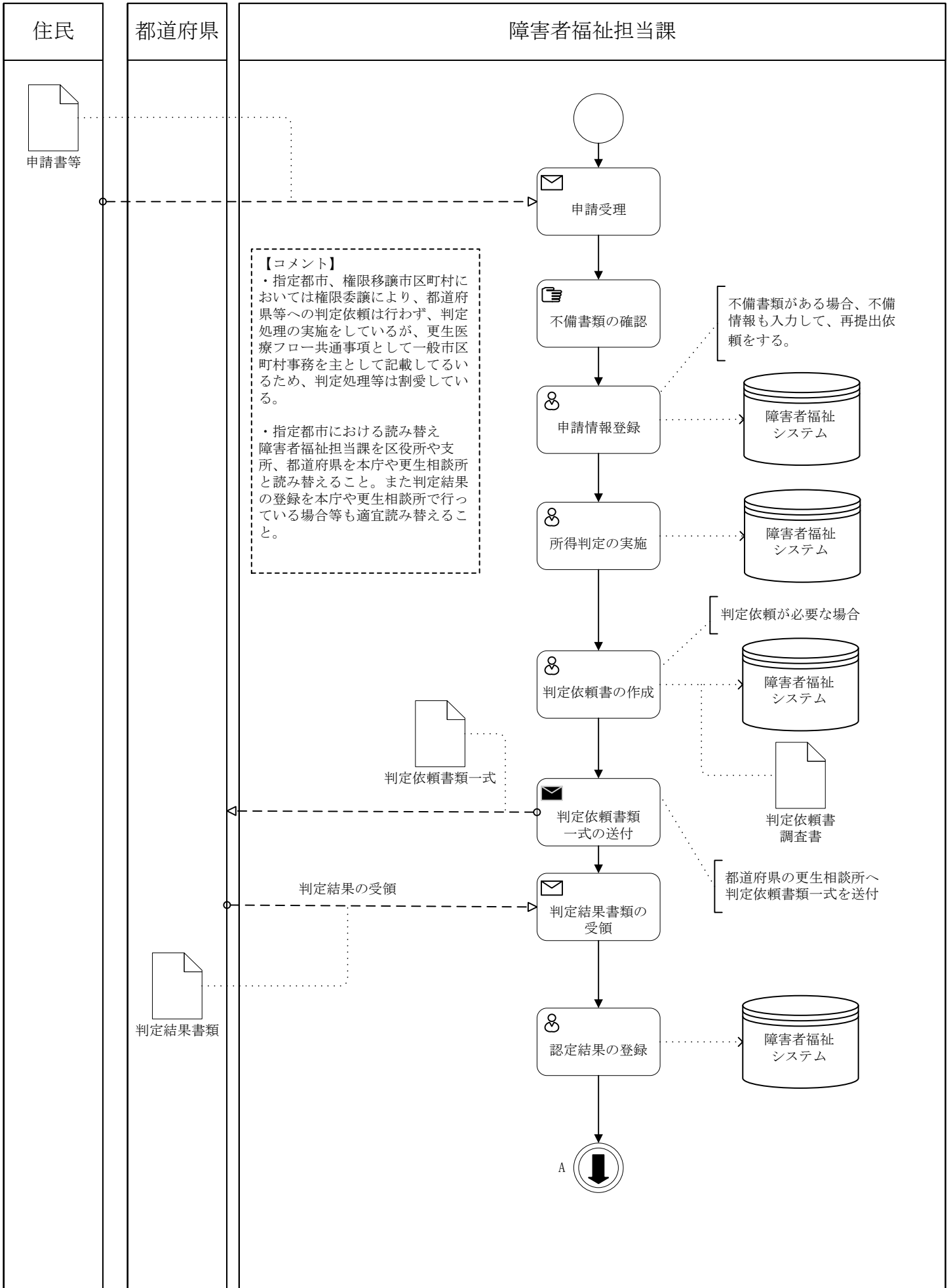

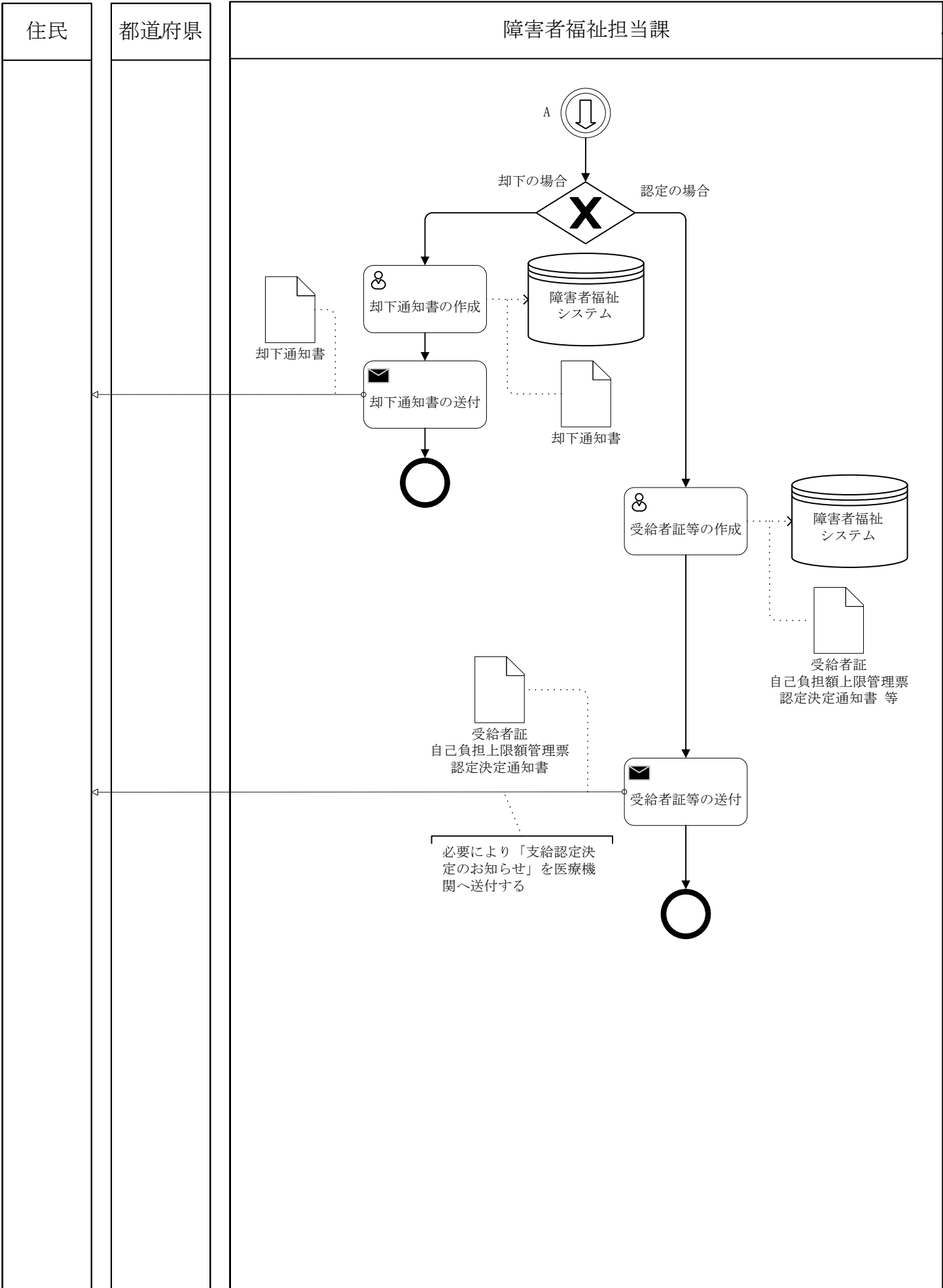



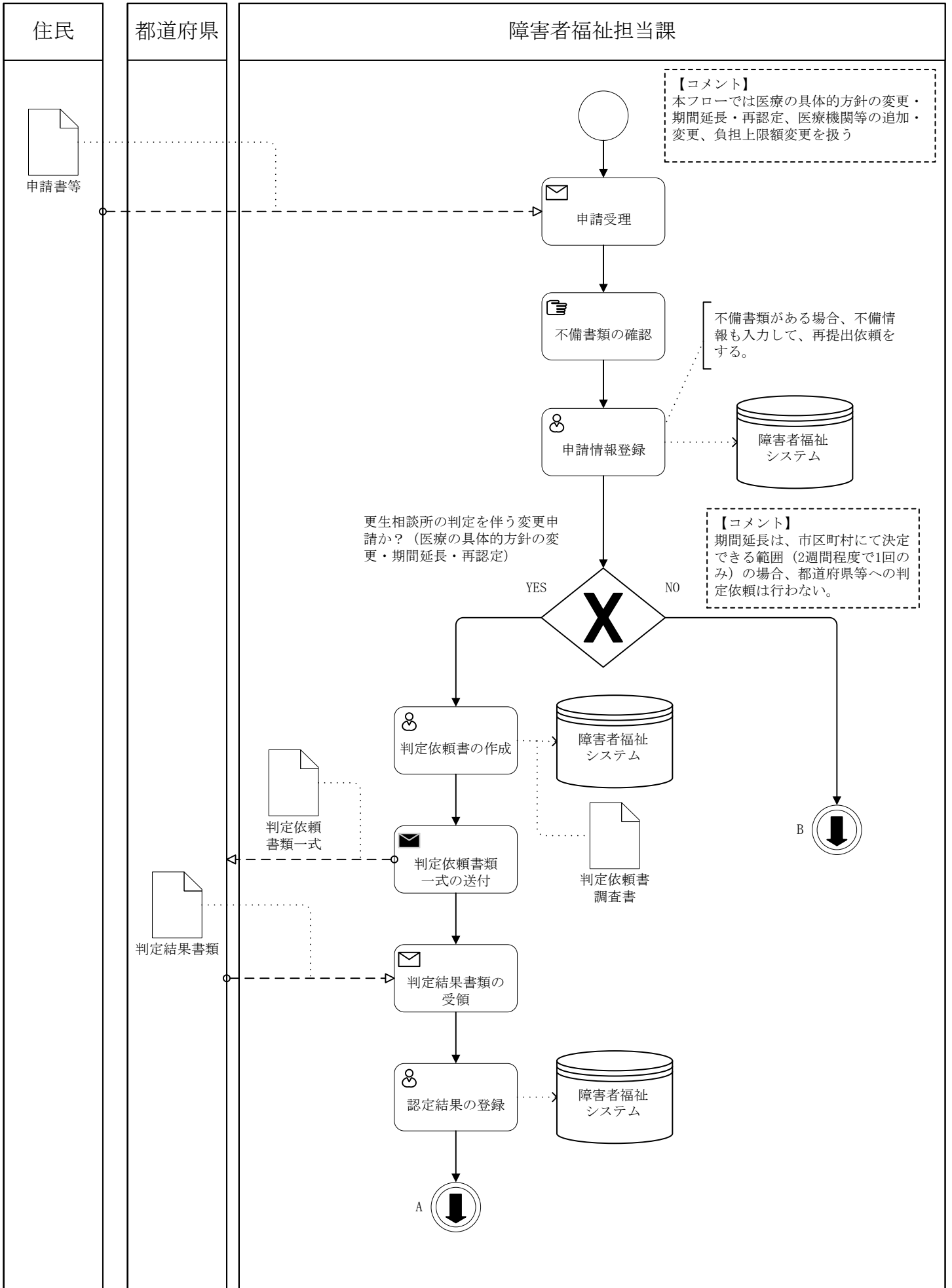

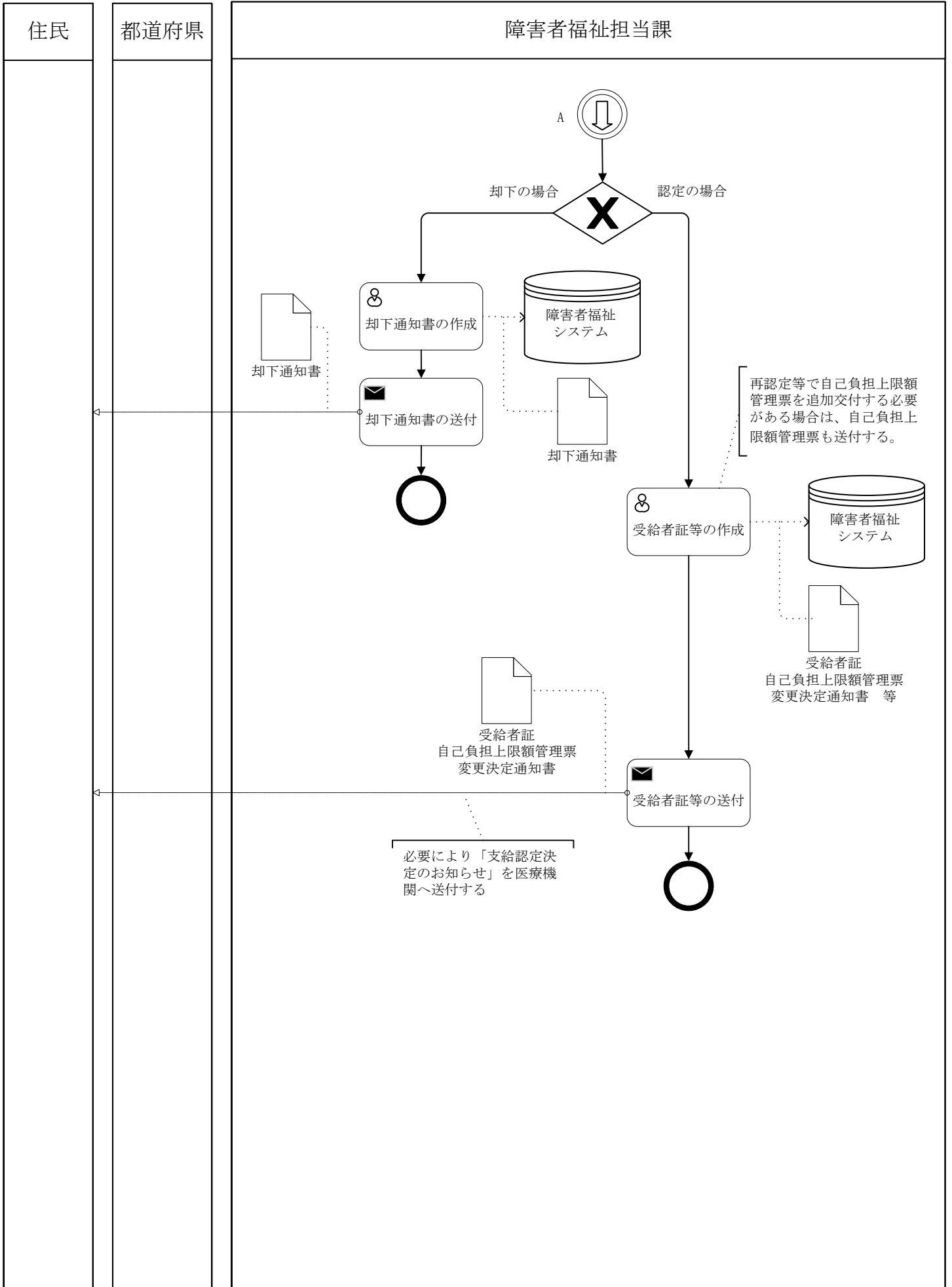

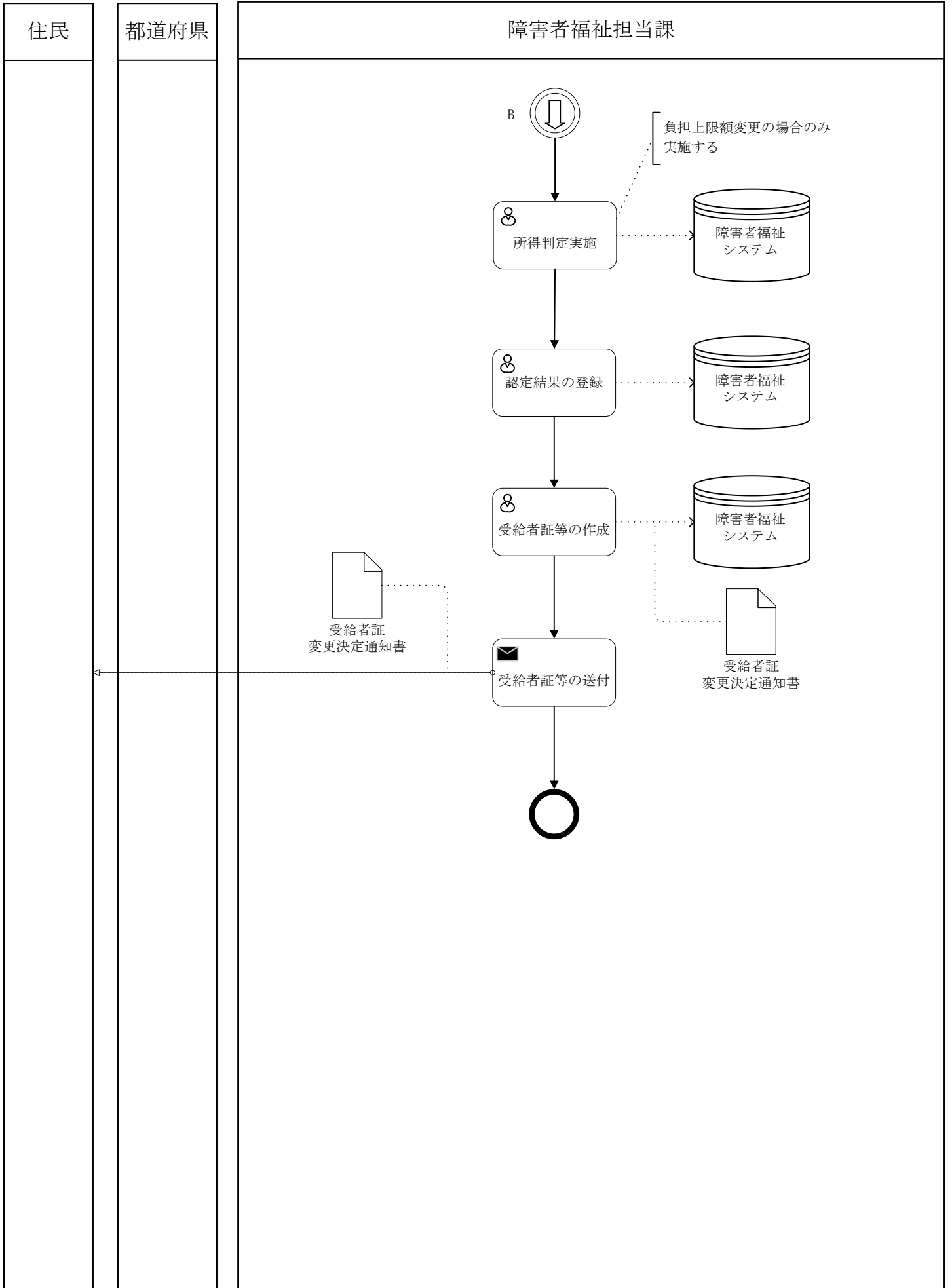

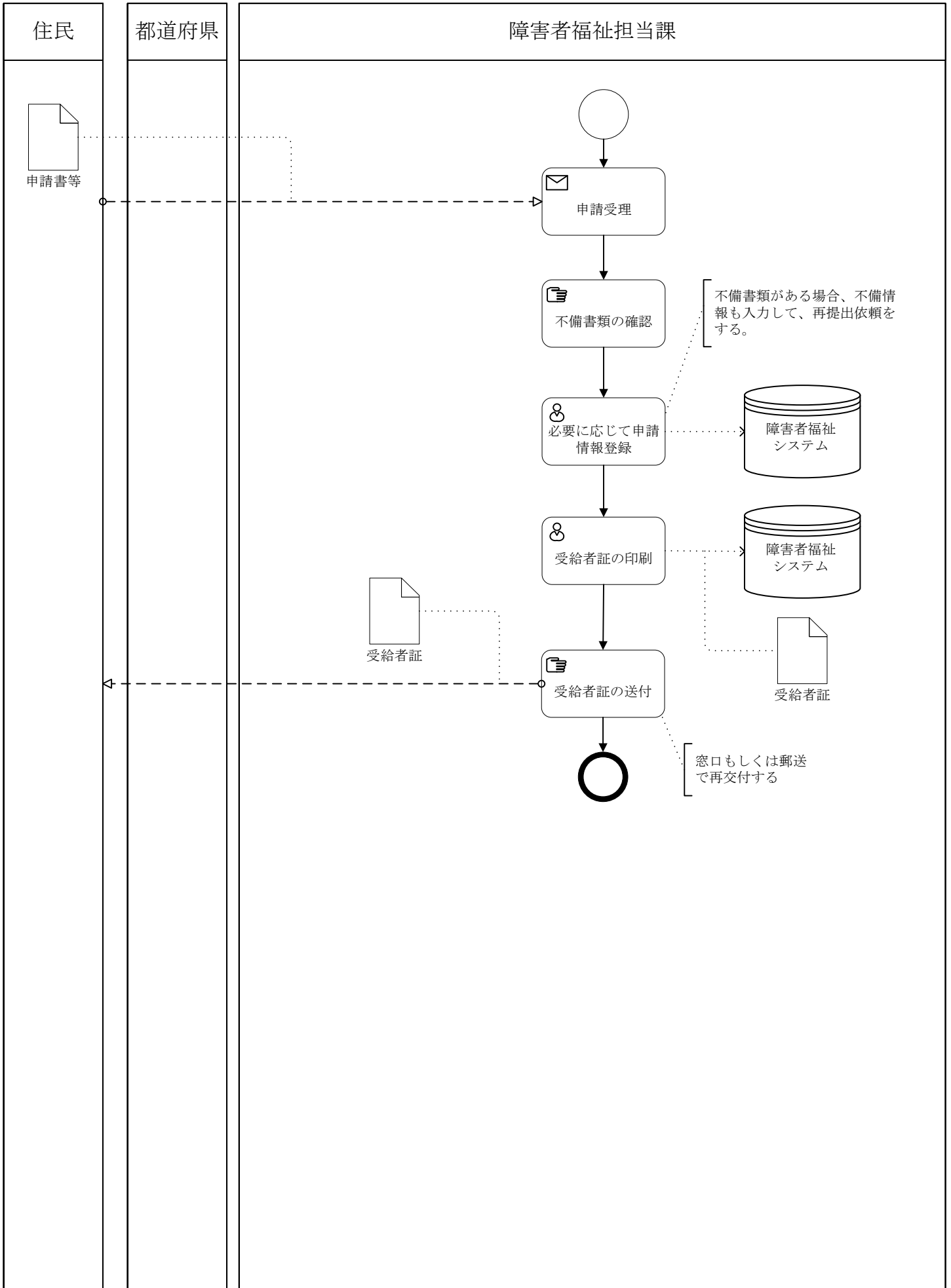



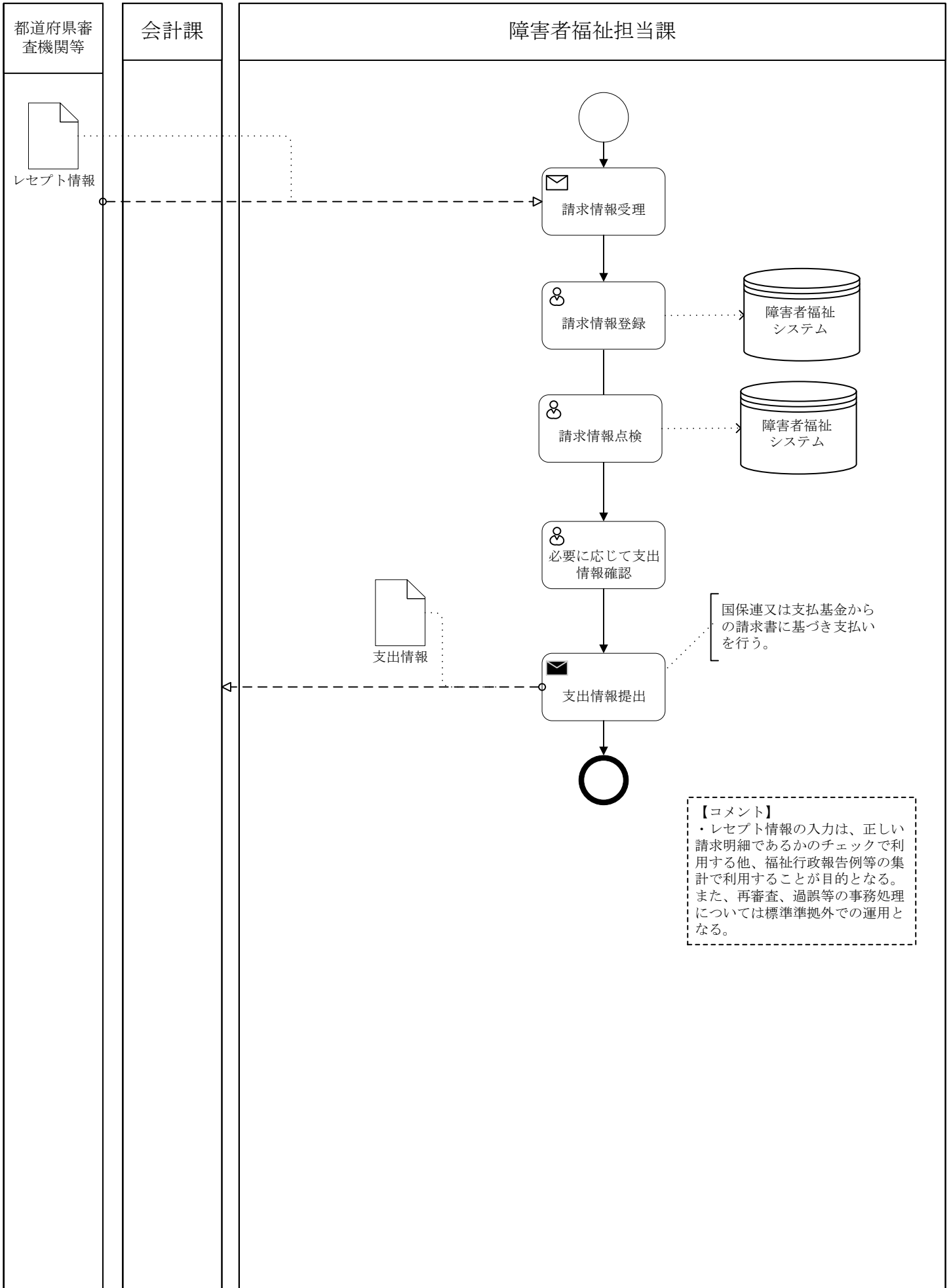

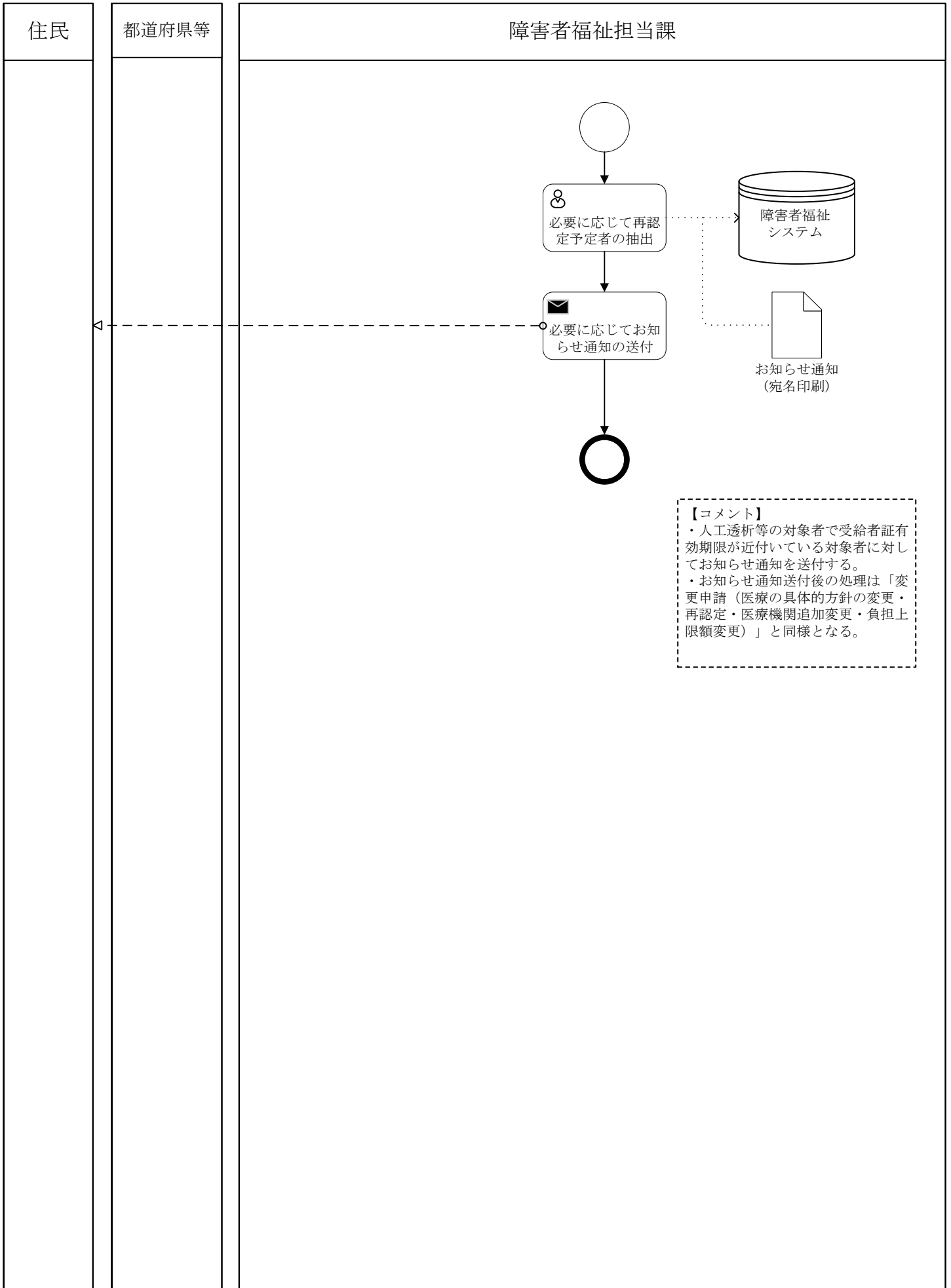

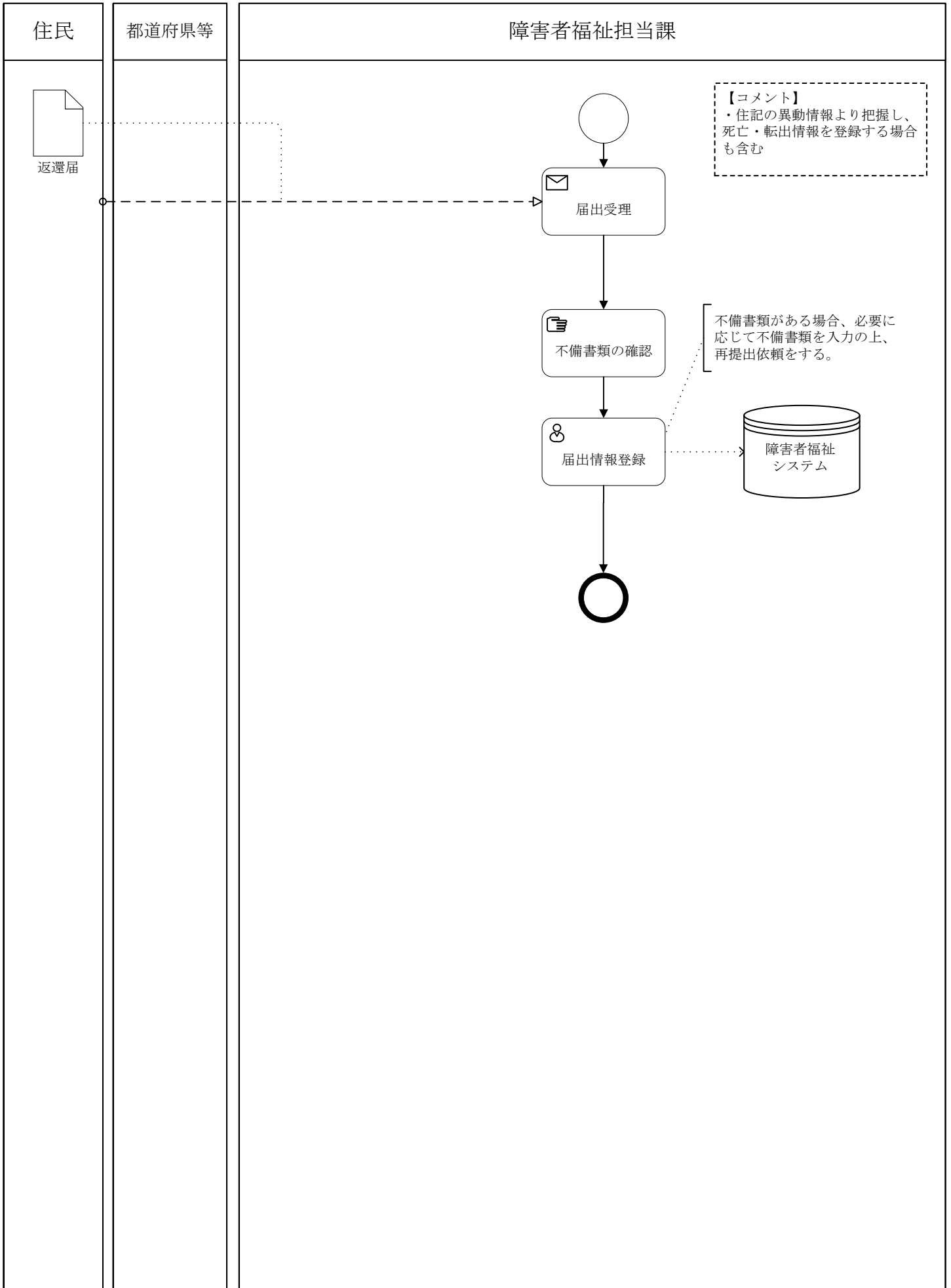

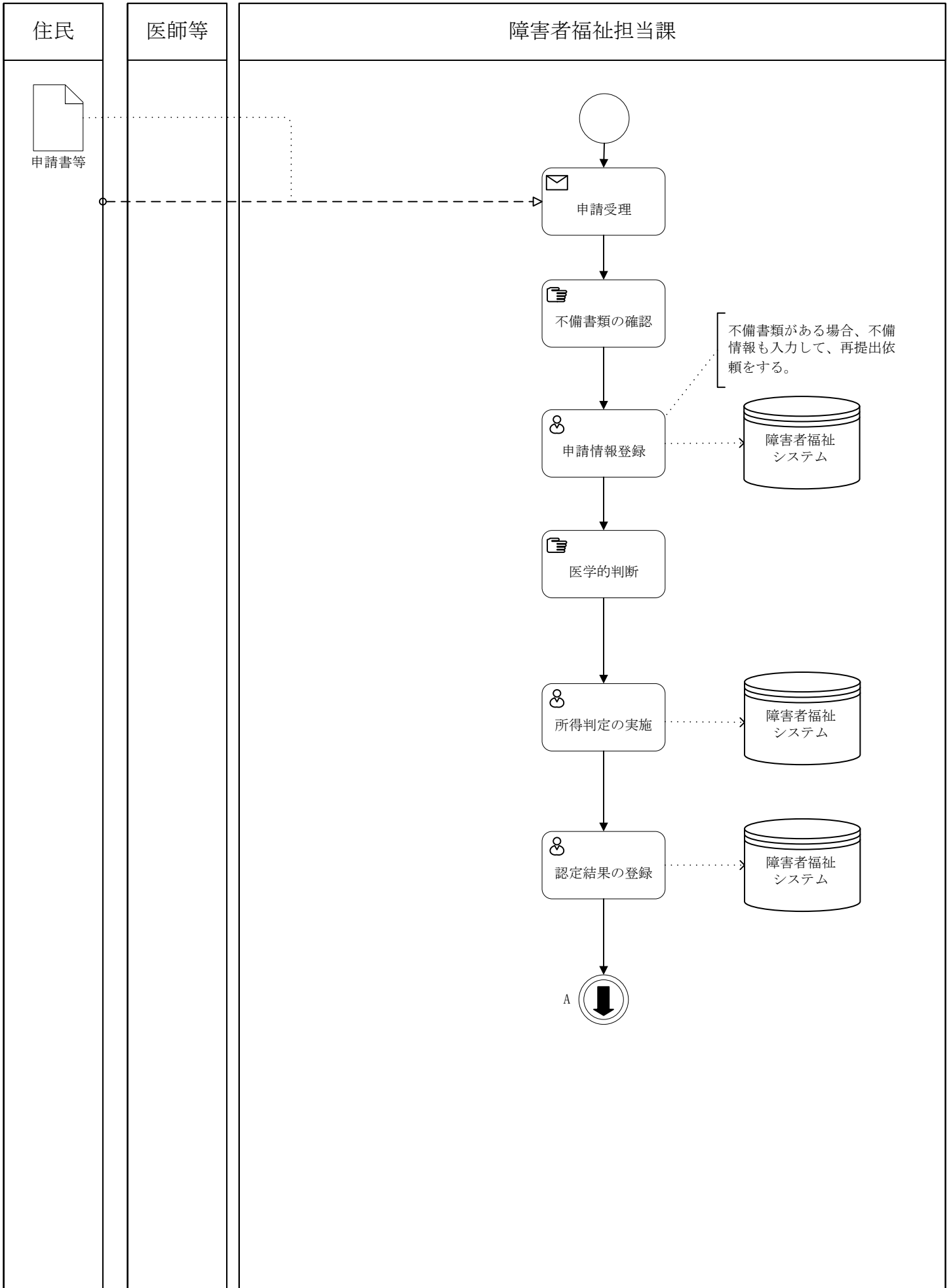

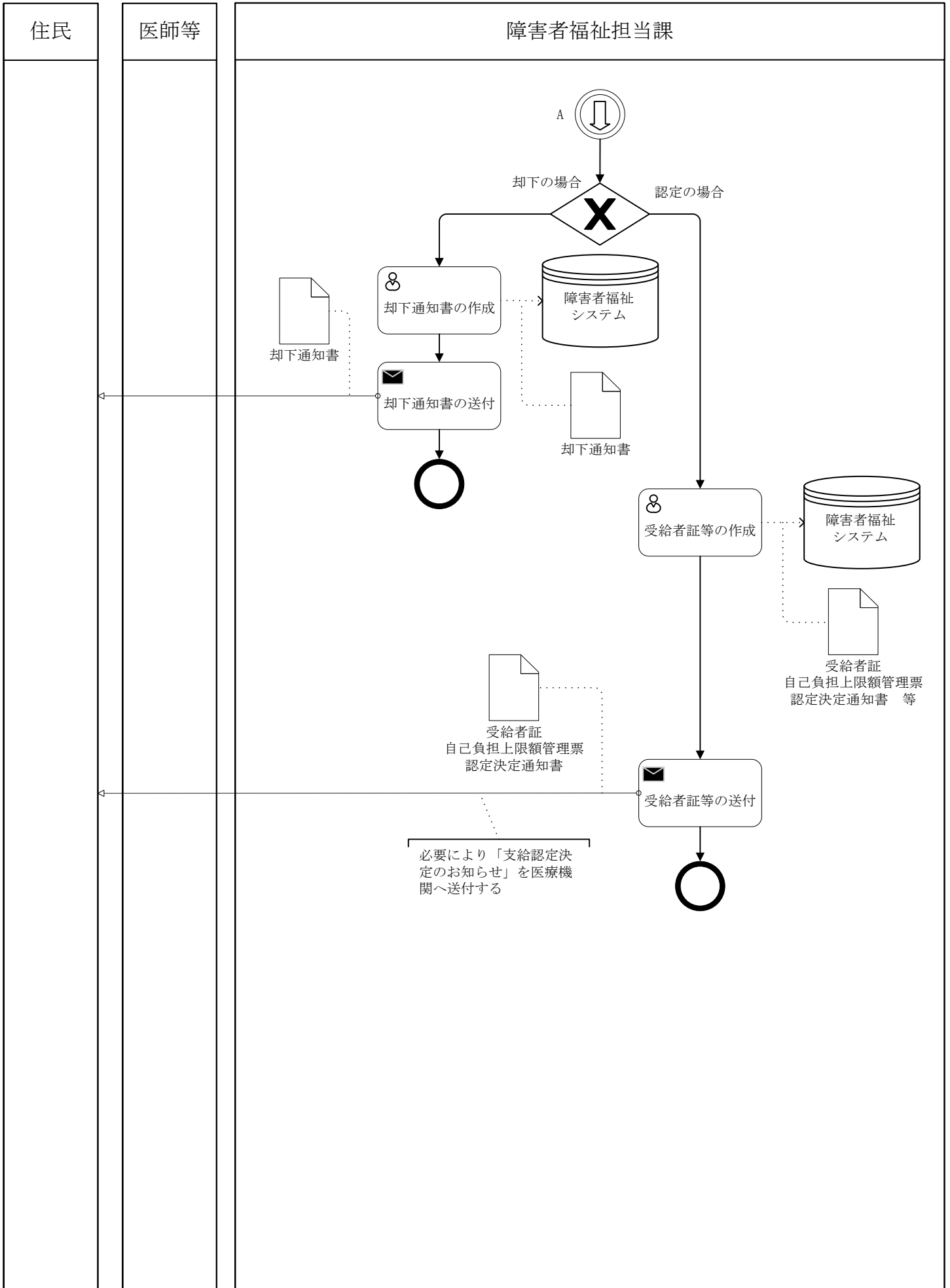

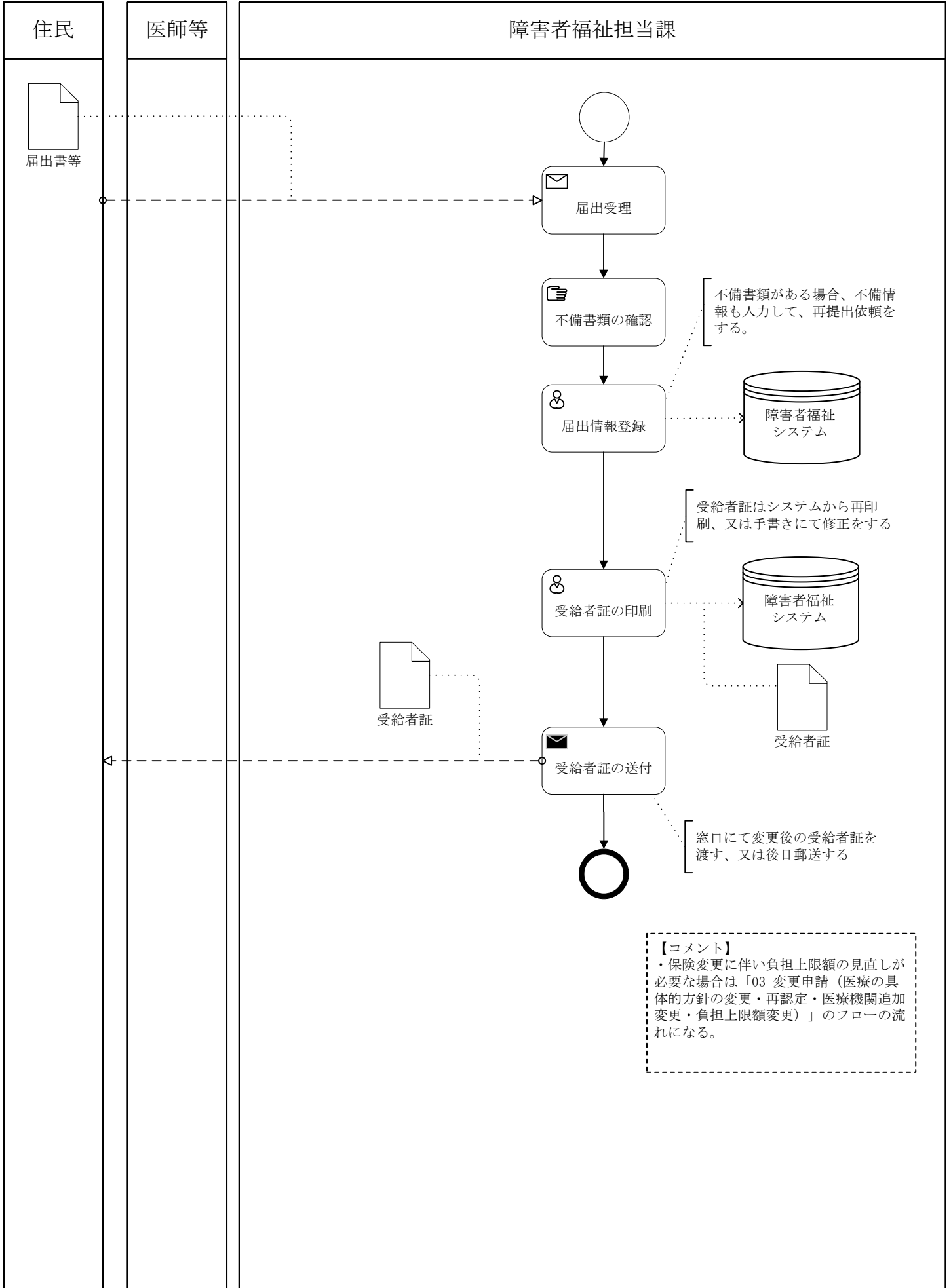

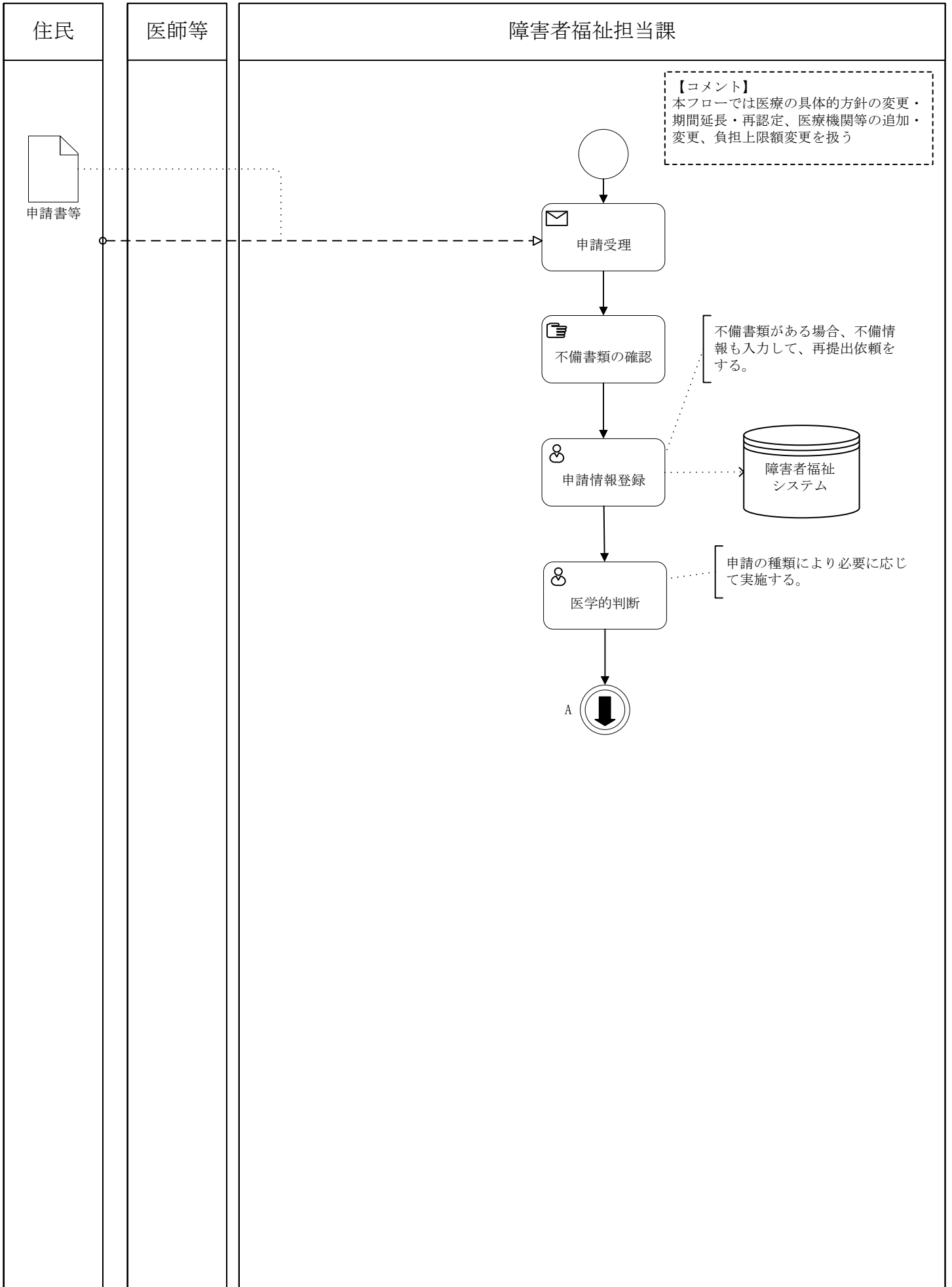

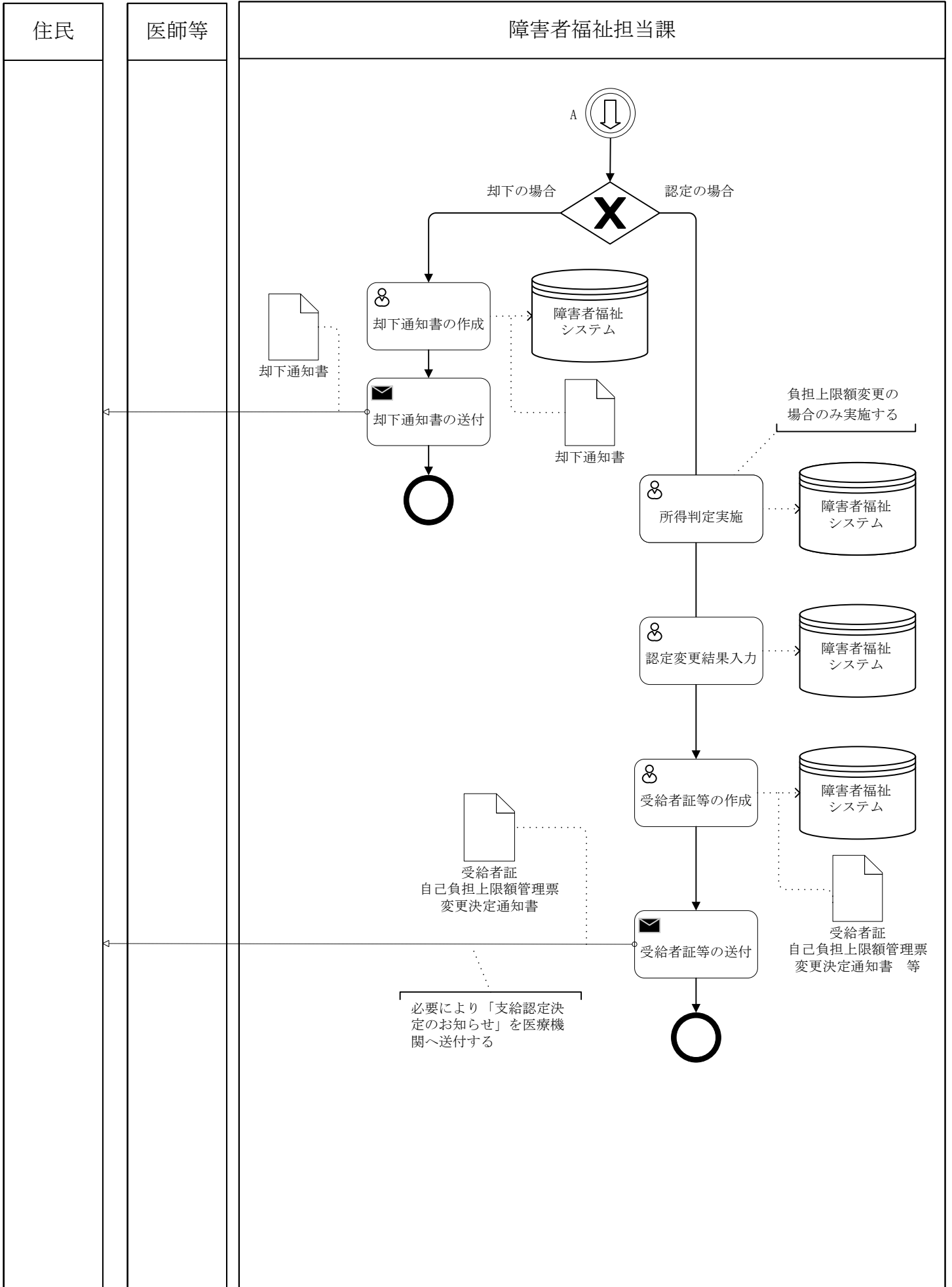



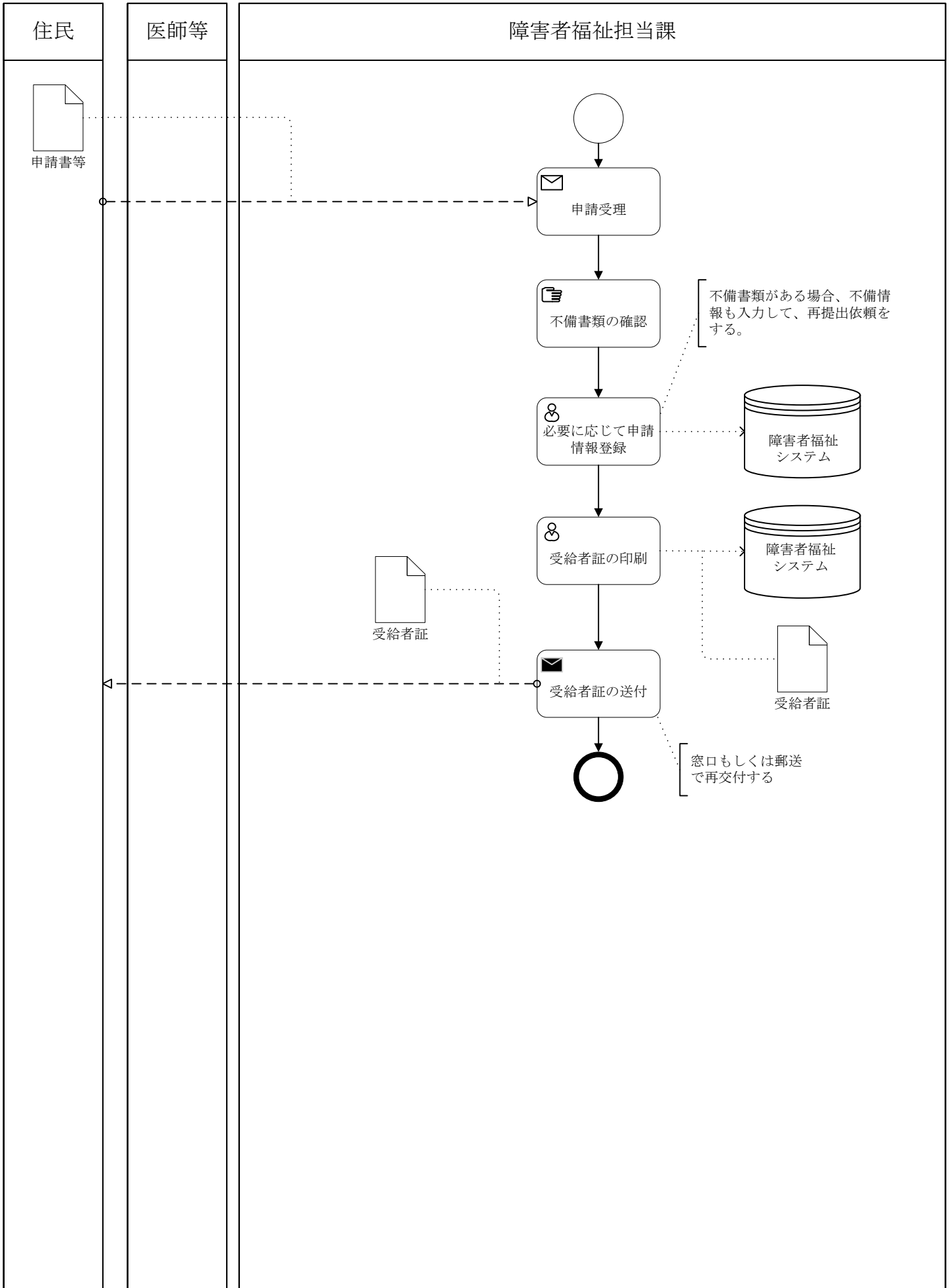

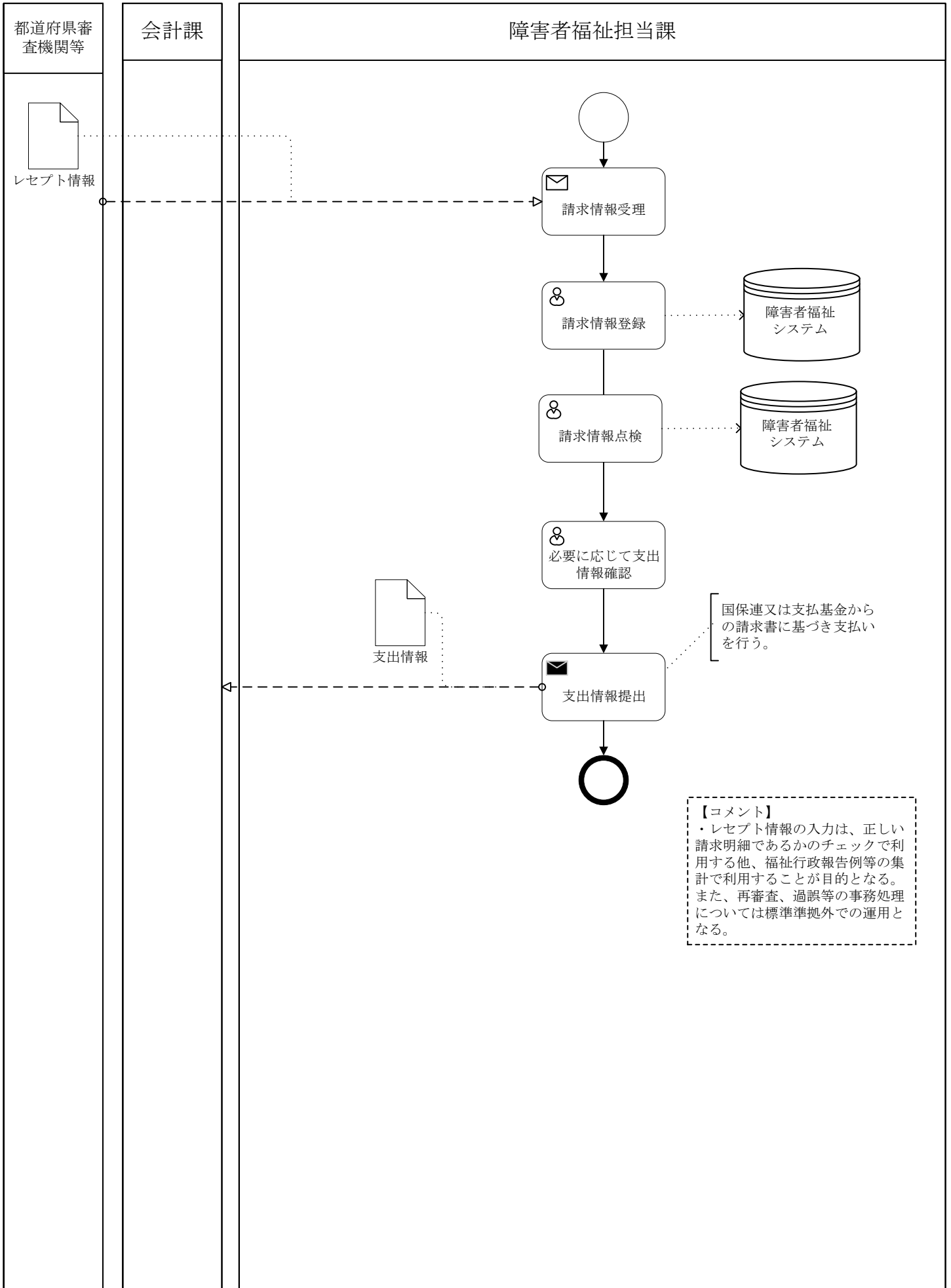

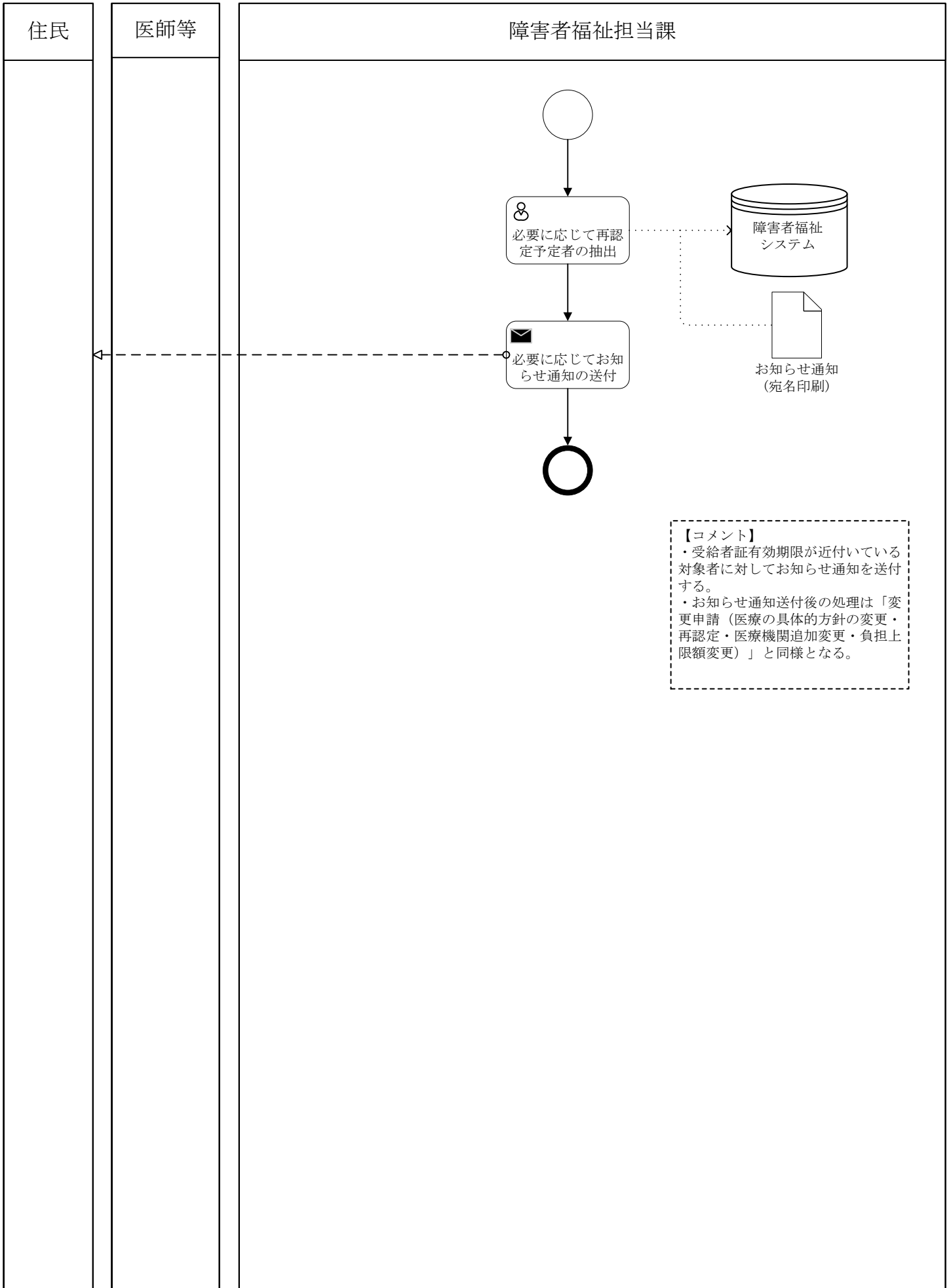

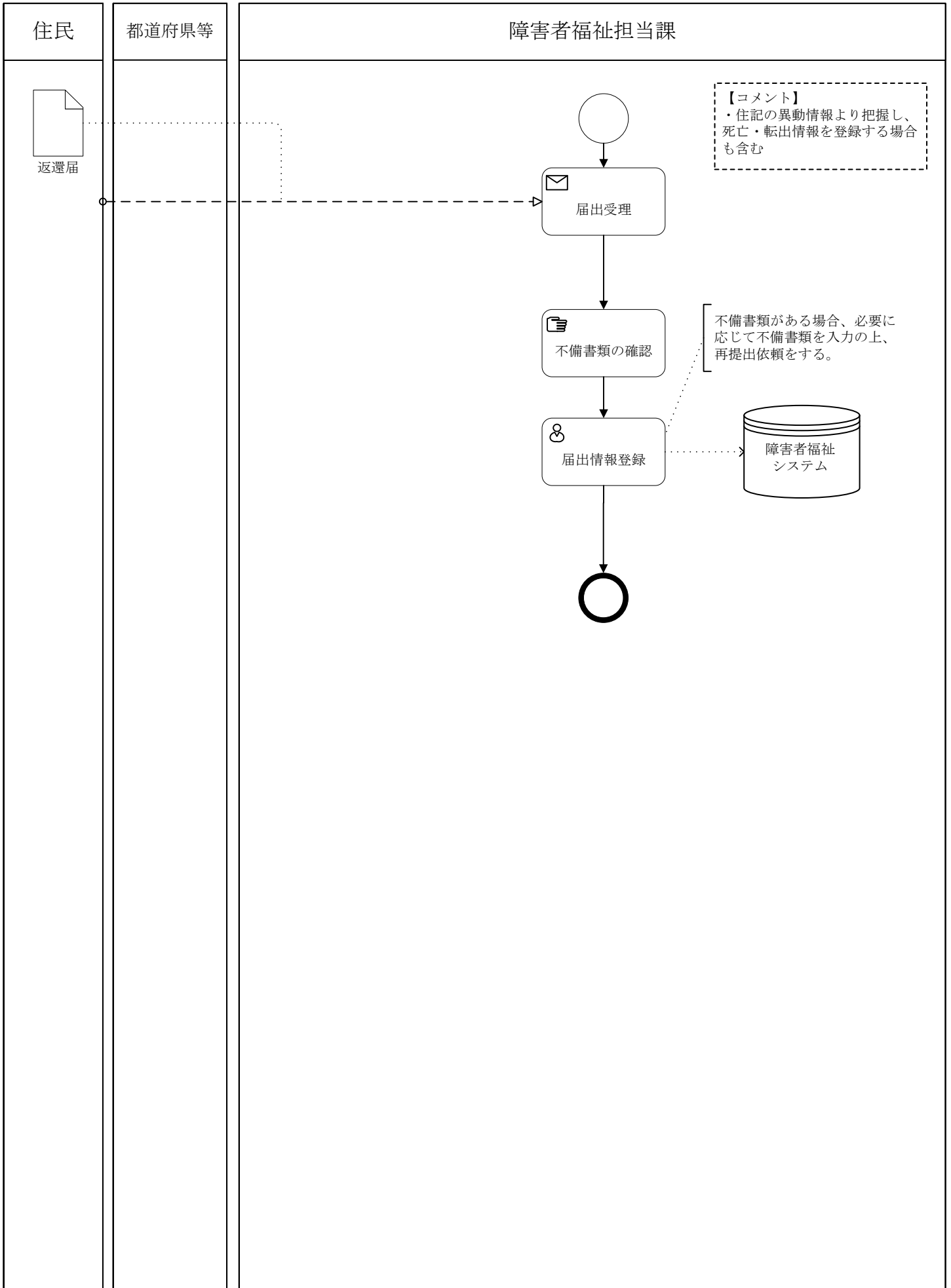

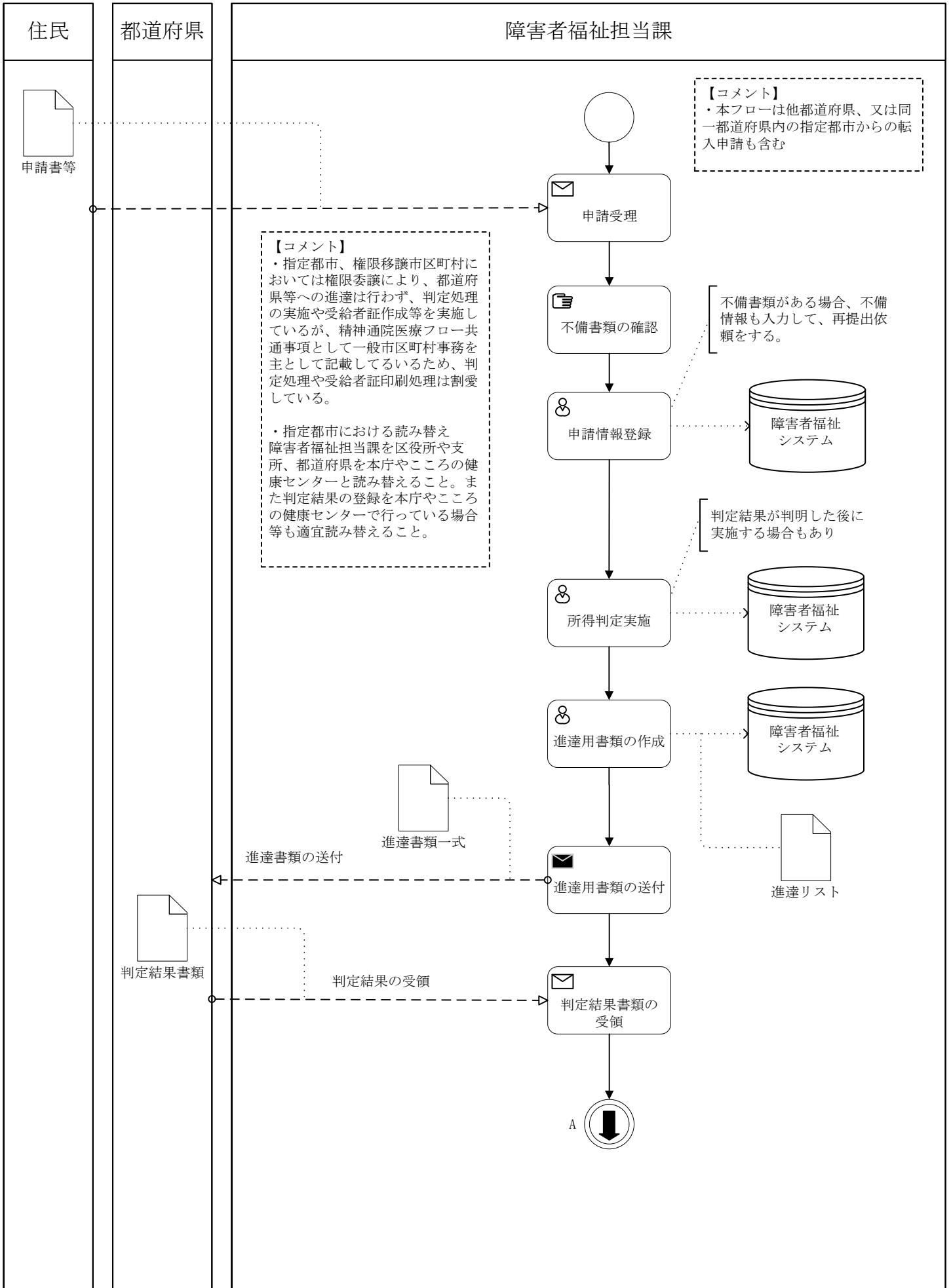

|    |         |     |           |     |         |
|----|---------|-----|-----------|-----|---------|
| 区分 | 1 障害者福祉 | 大分類 | 10 精神通院医療 | 小分類 | 01 新規申請 |
|----|---------|-----|-----------|-----|---------|

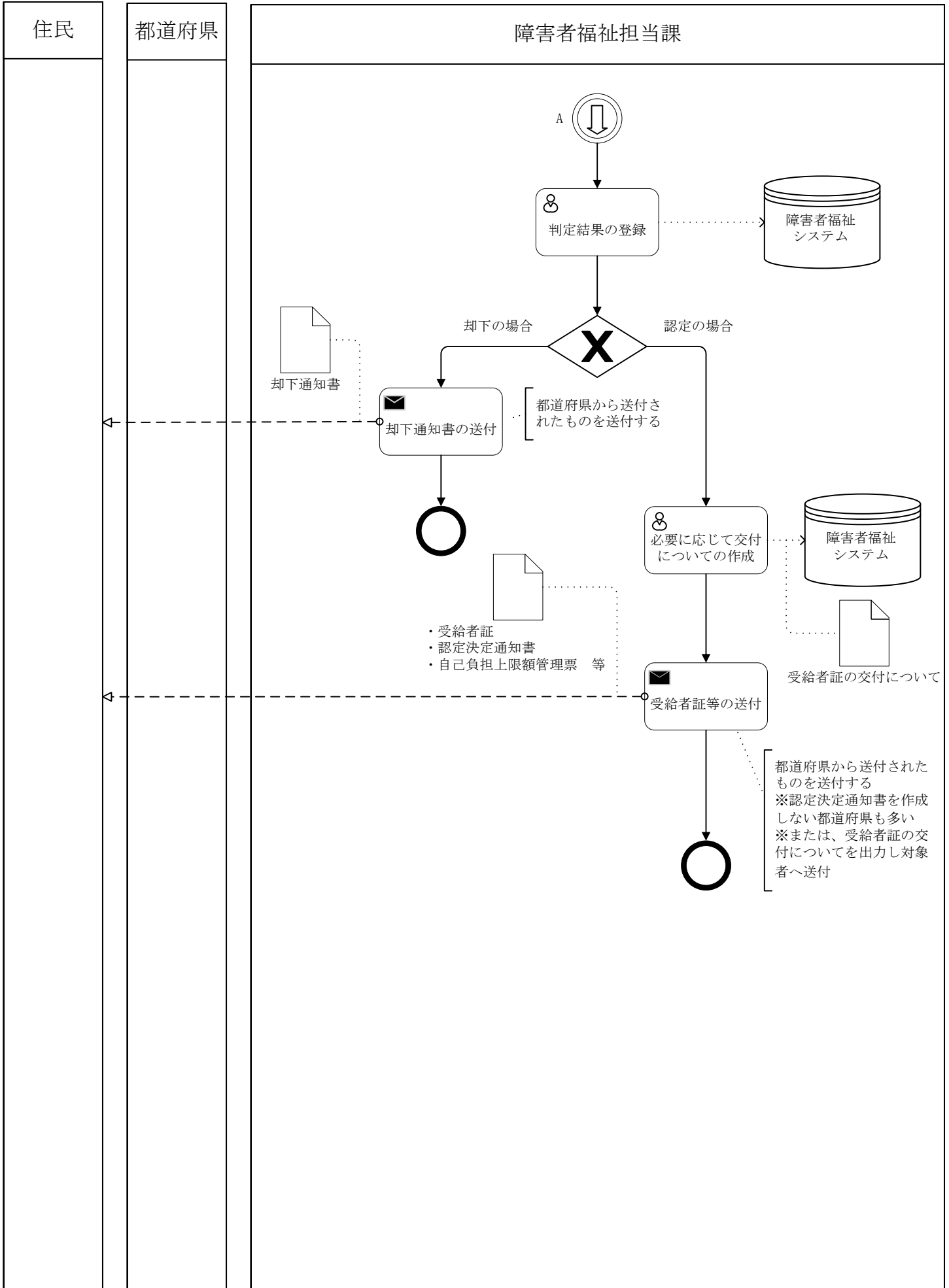

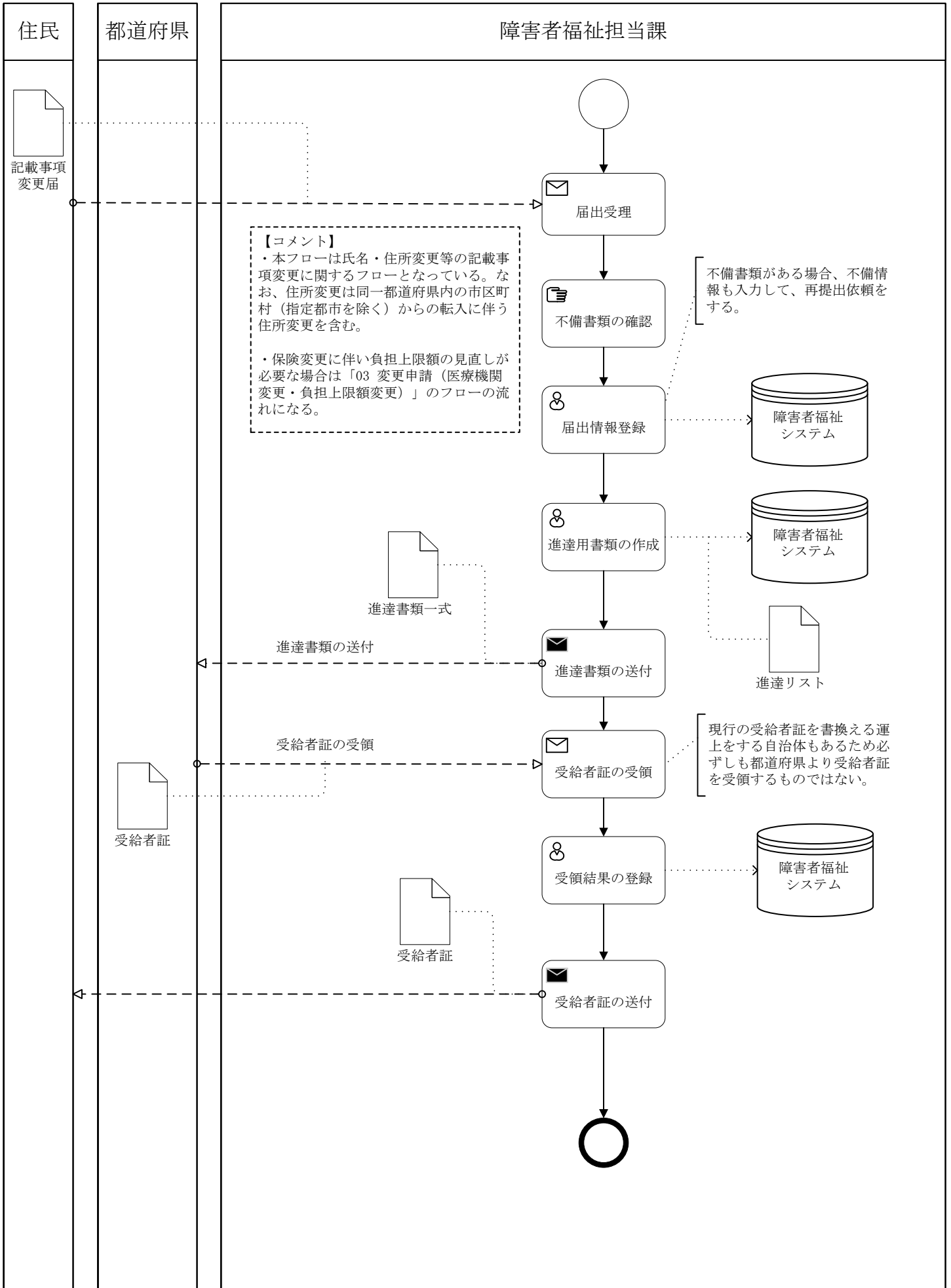

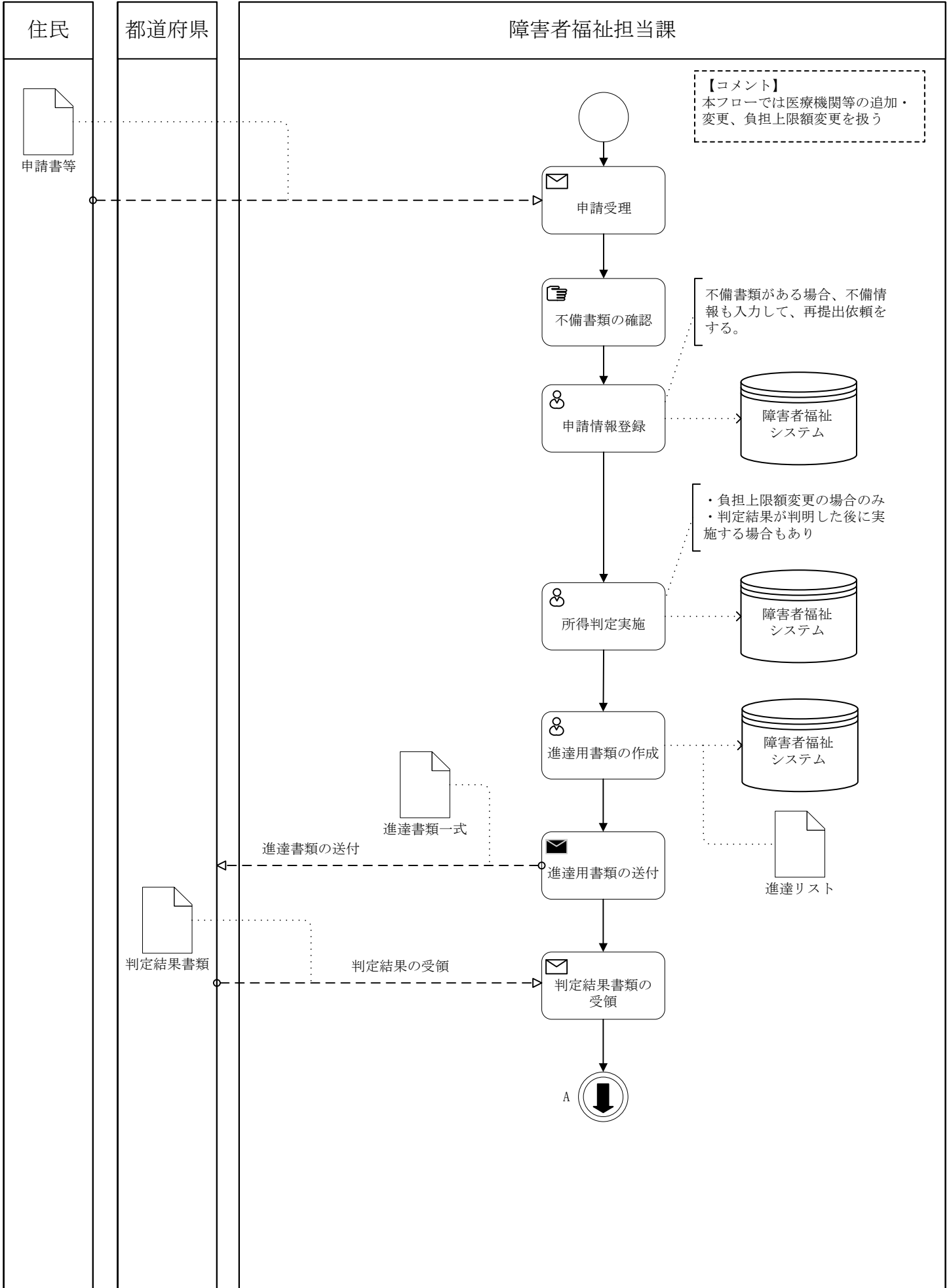



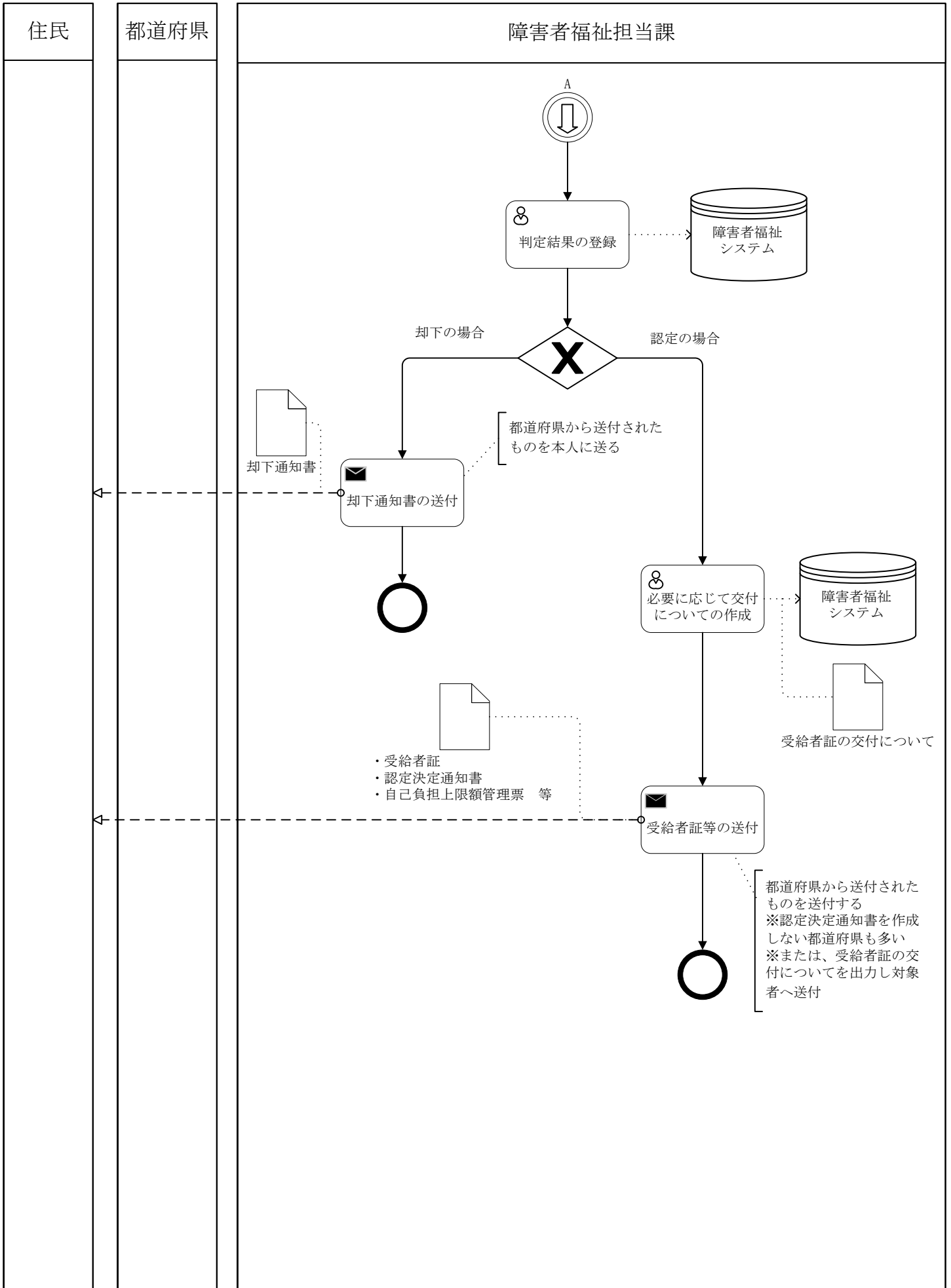

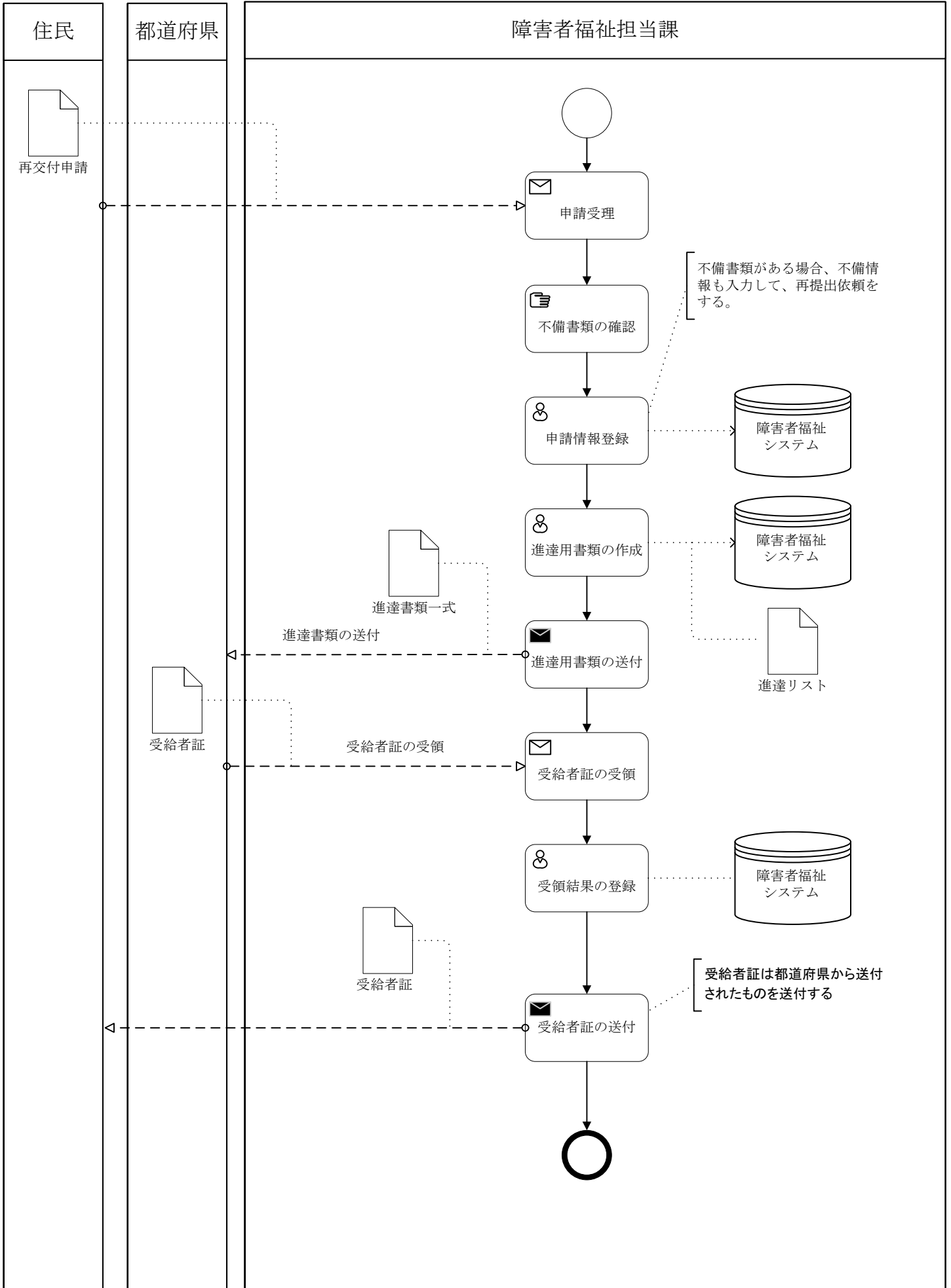

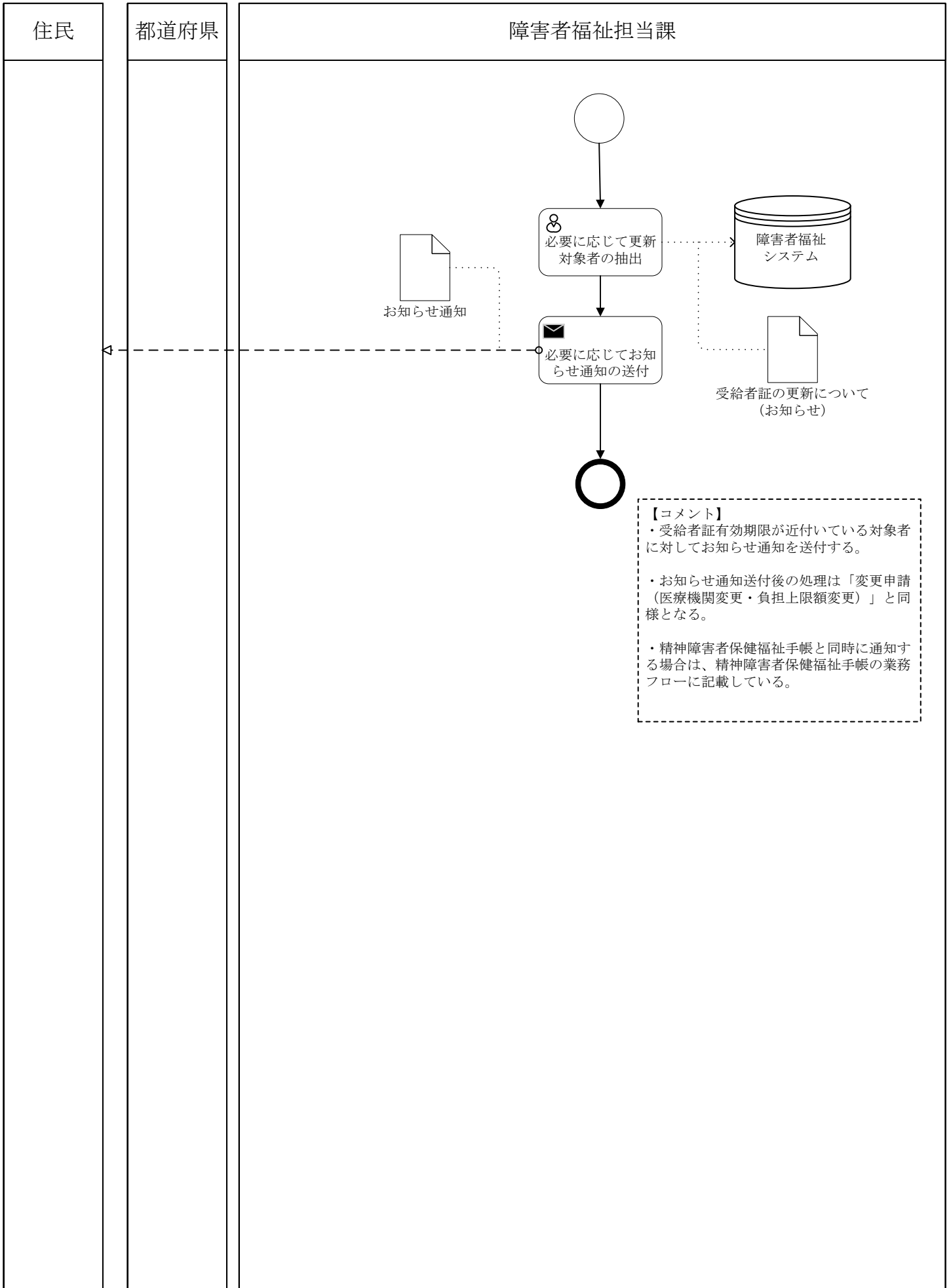

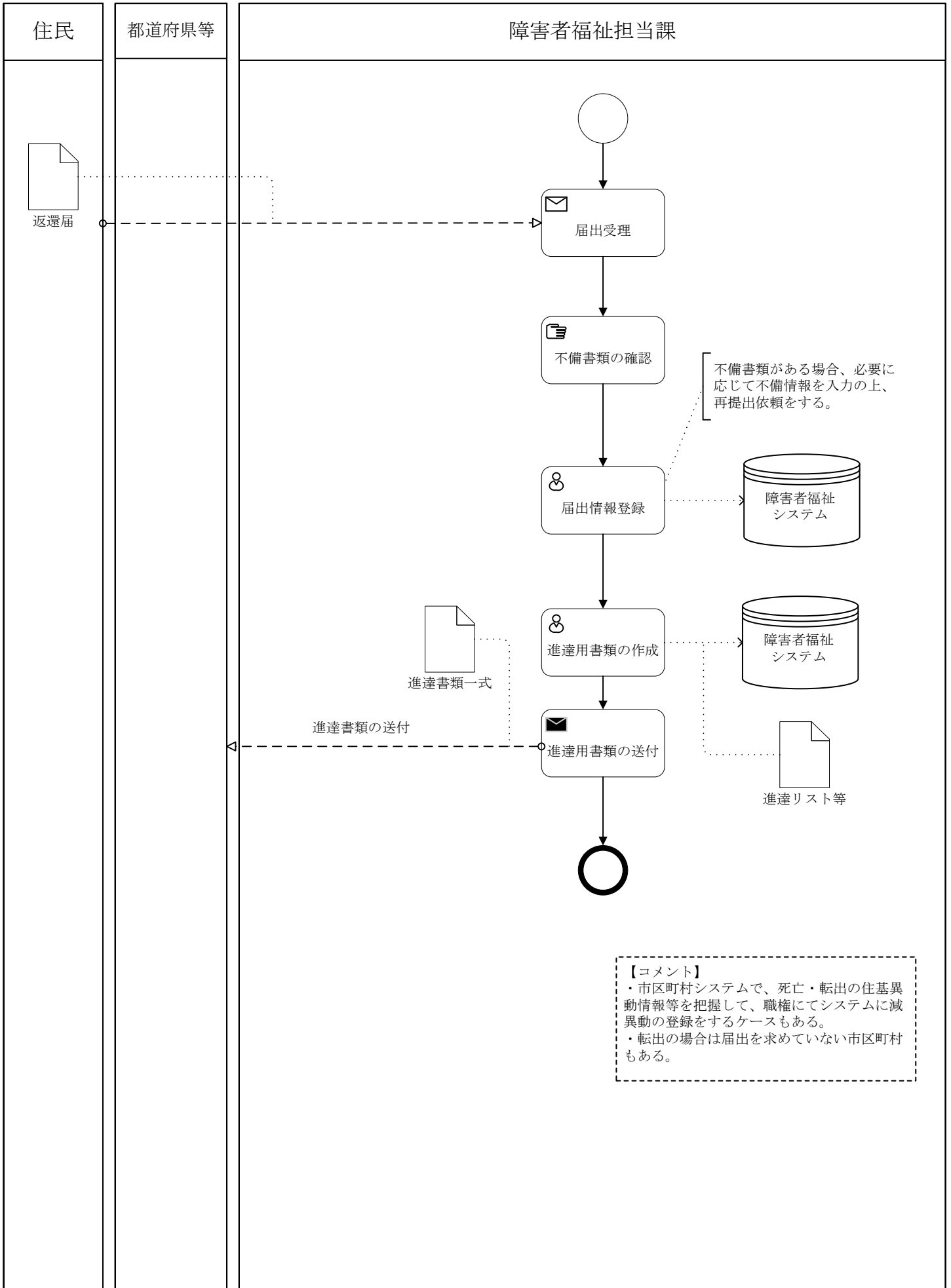

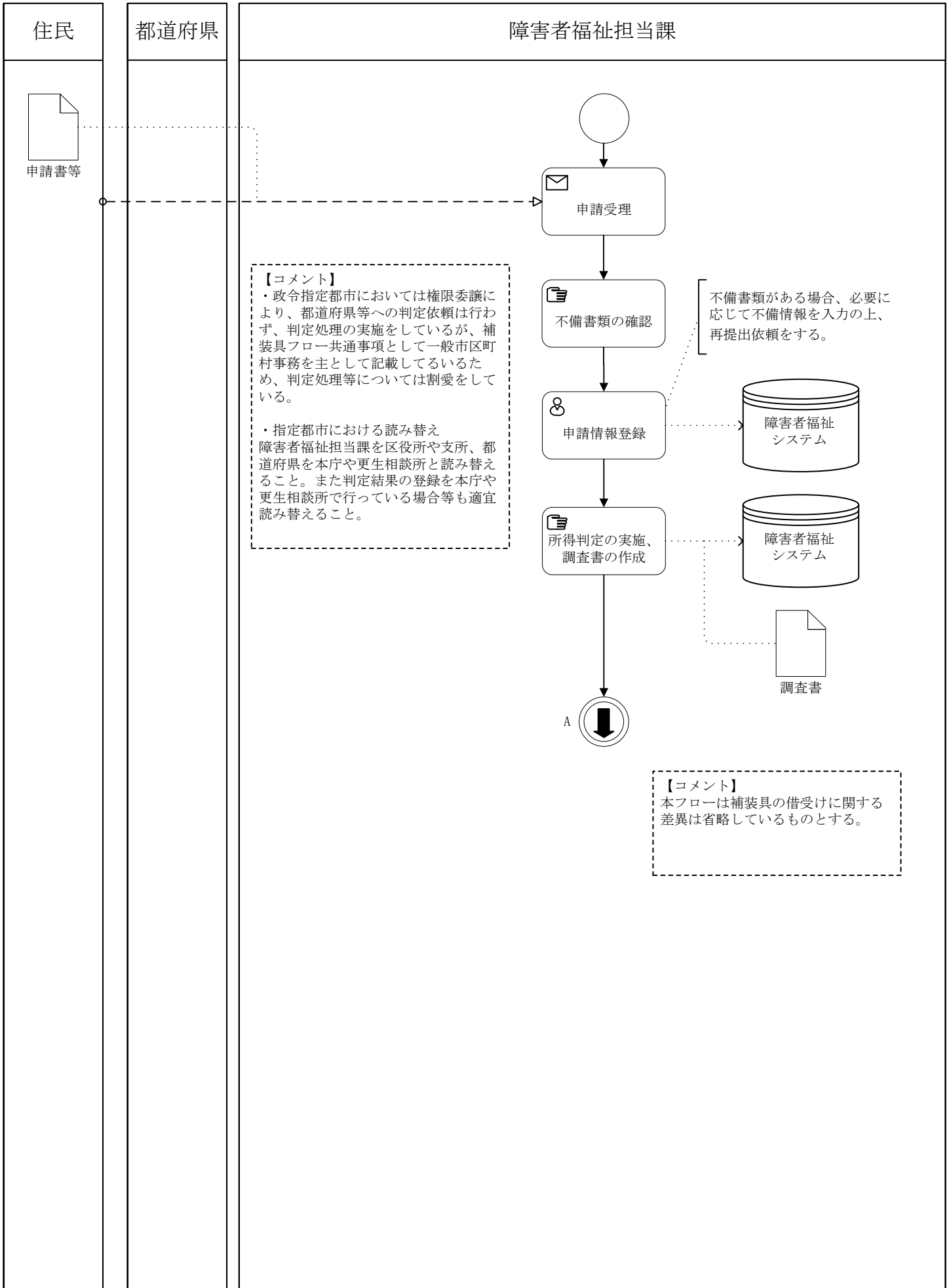

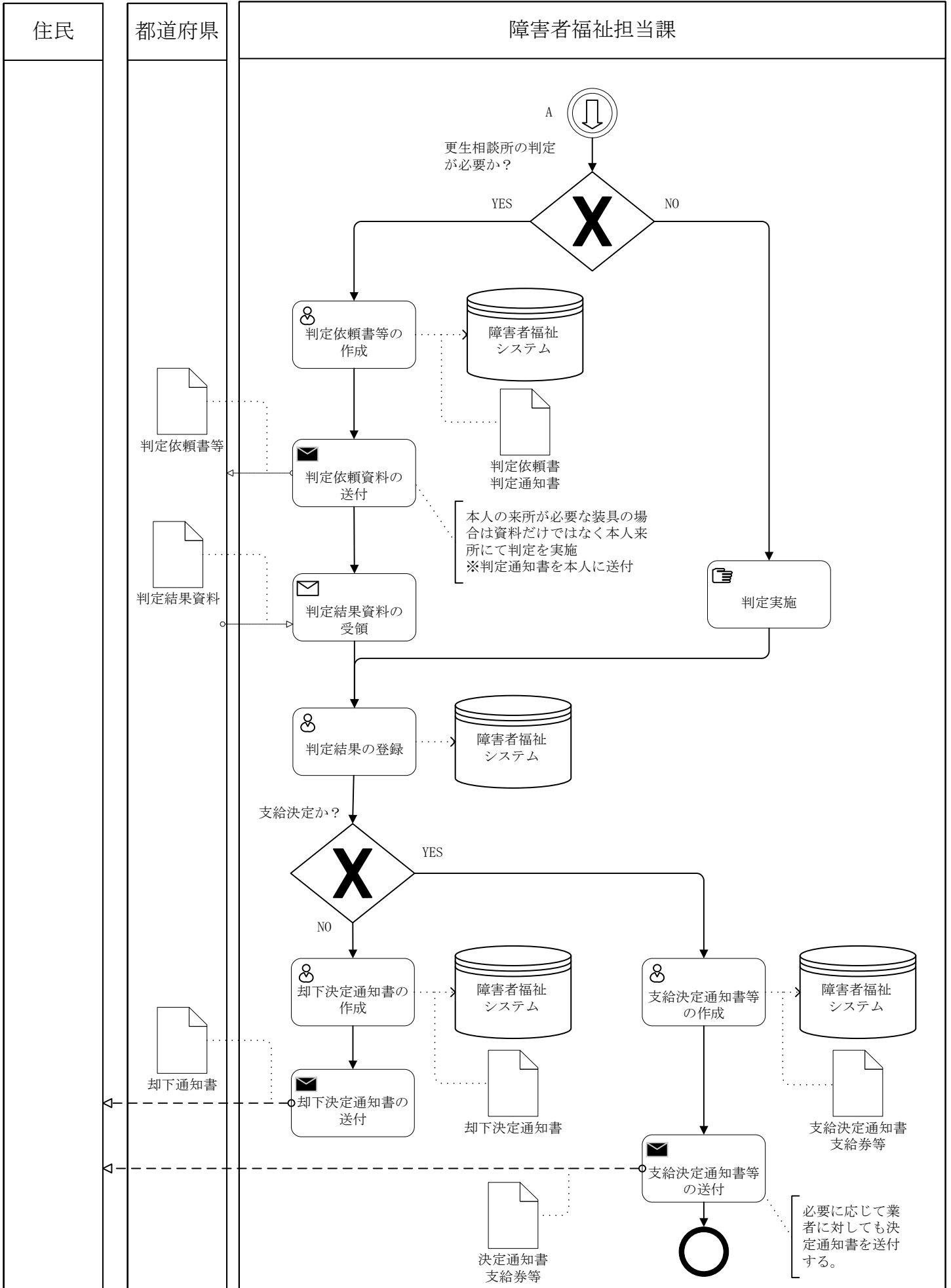

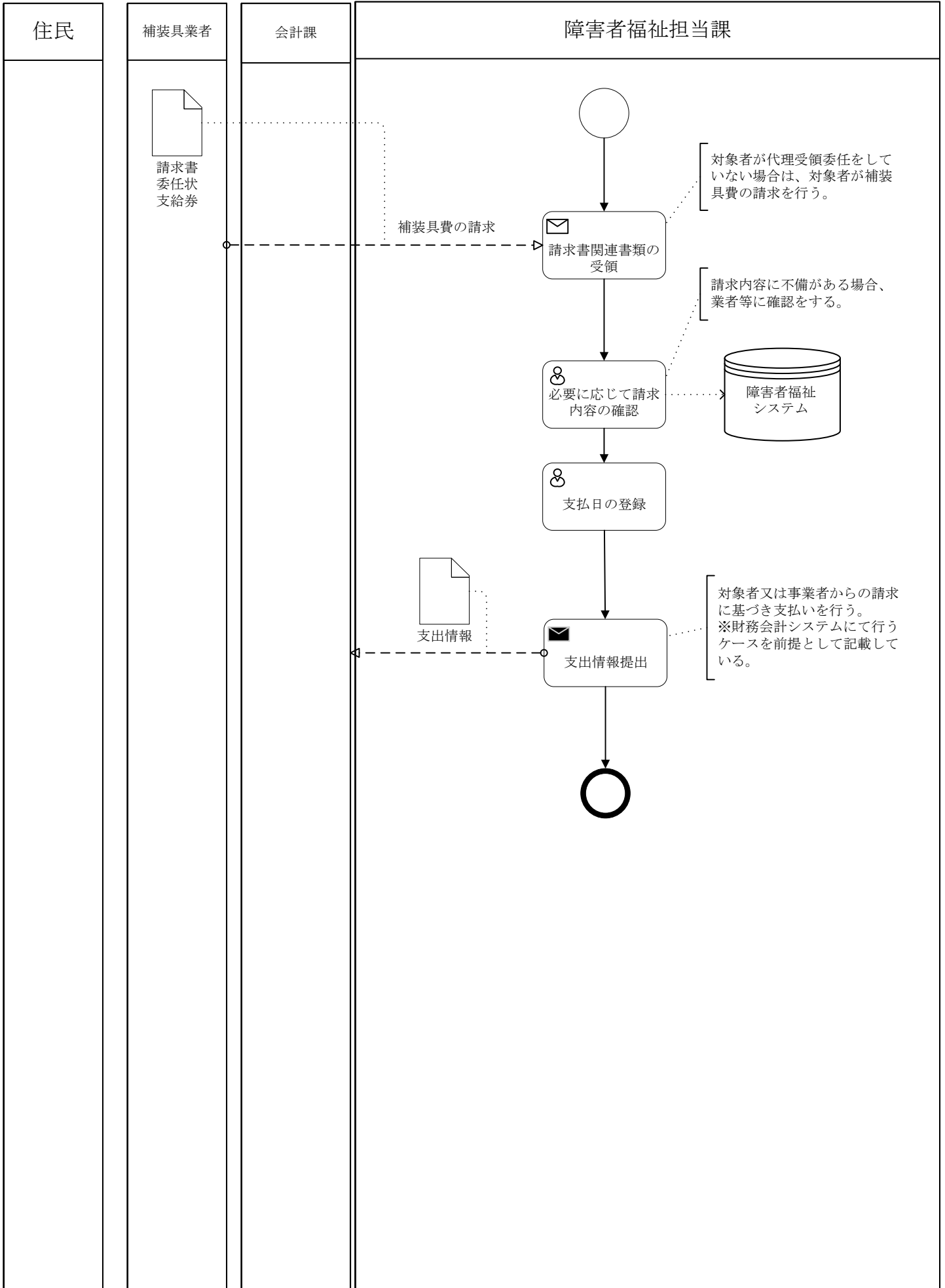

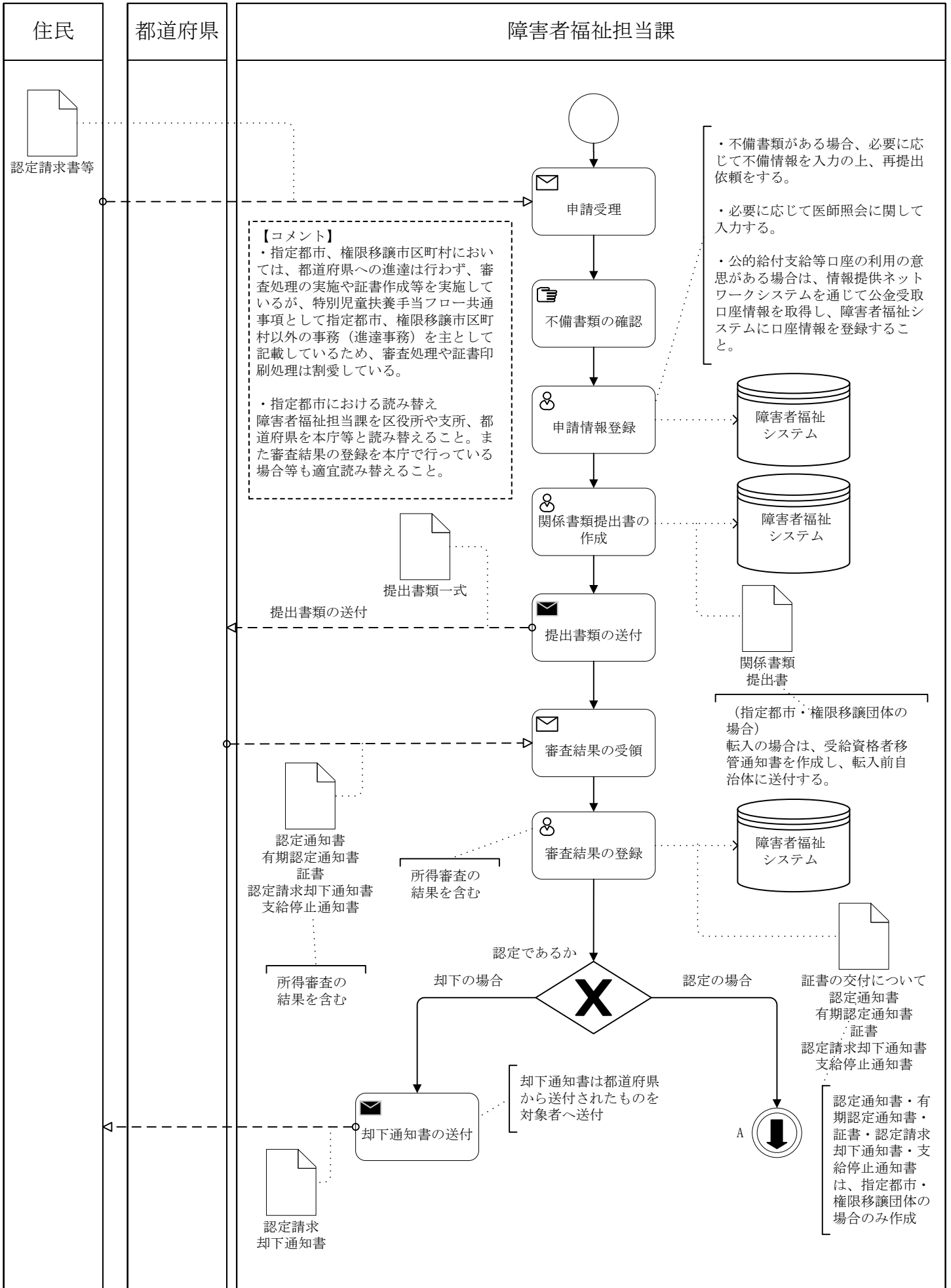



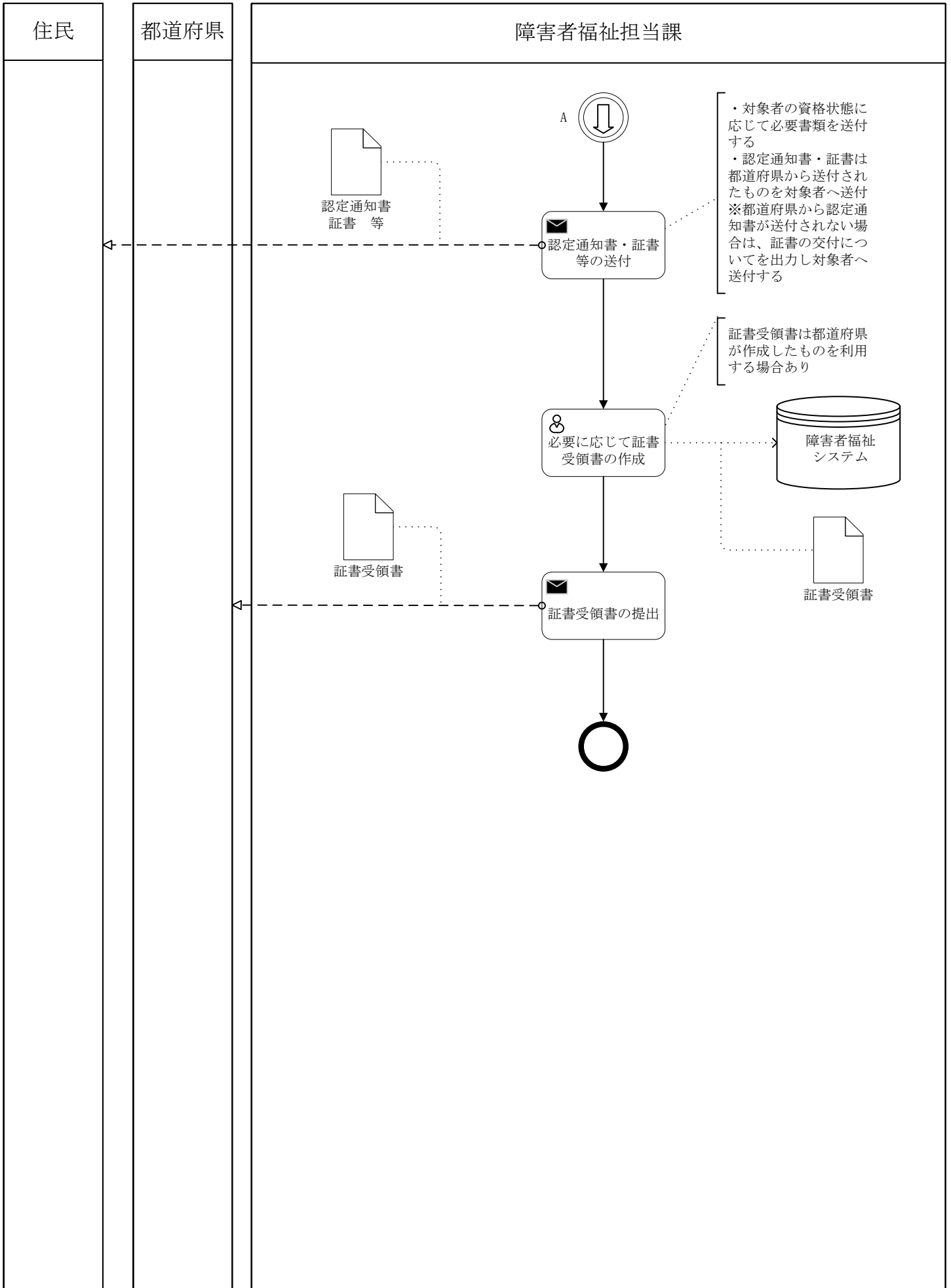

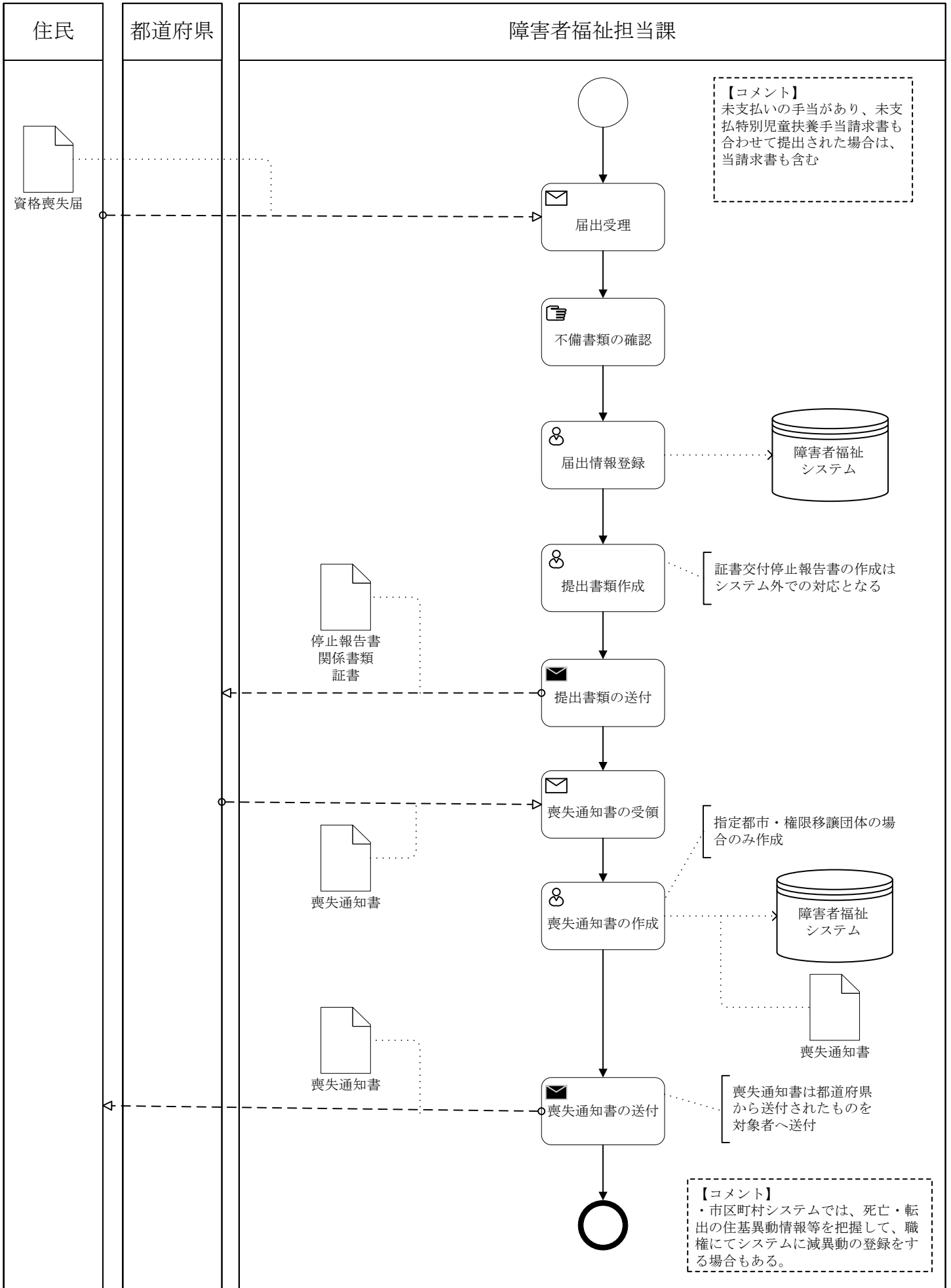

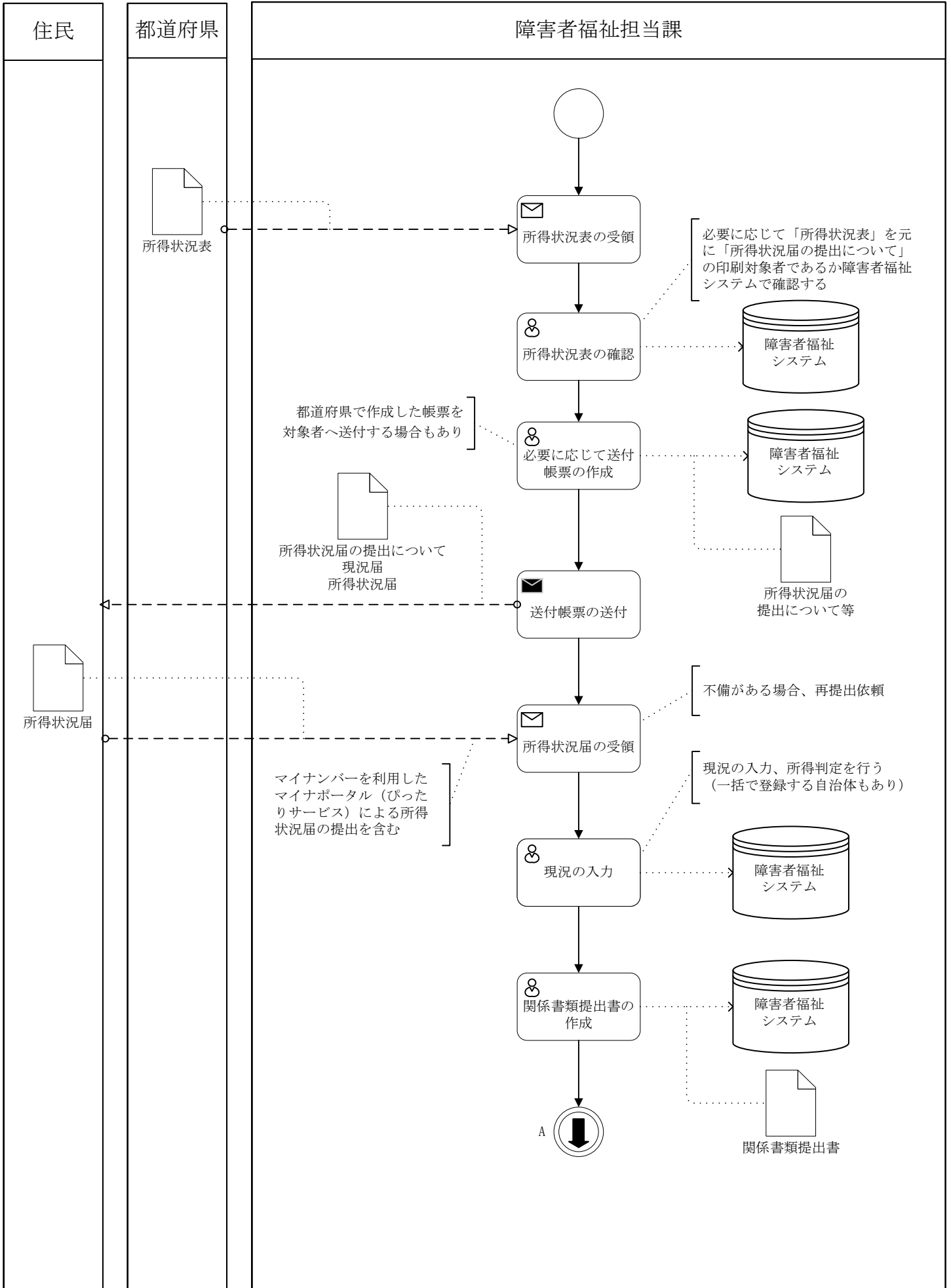

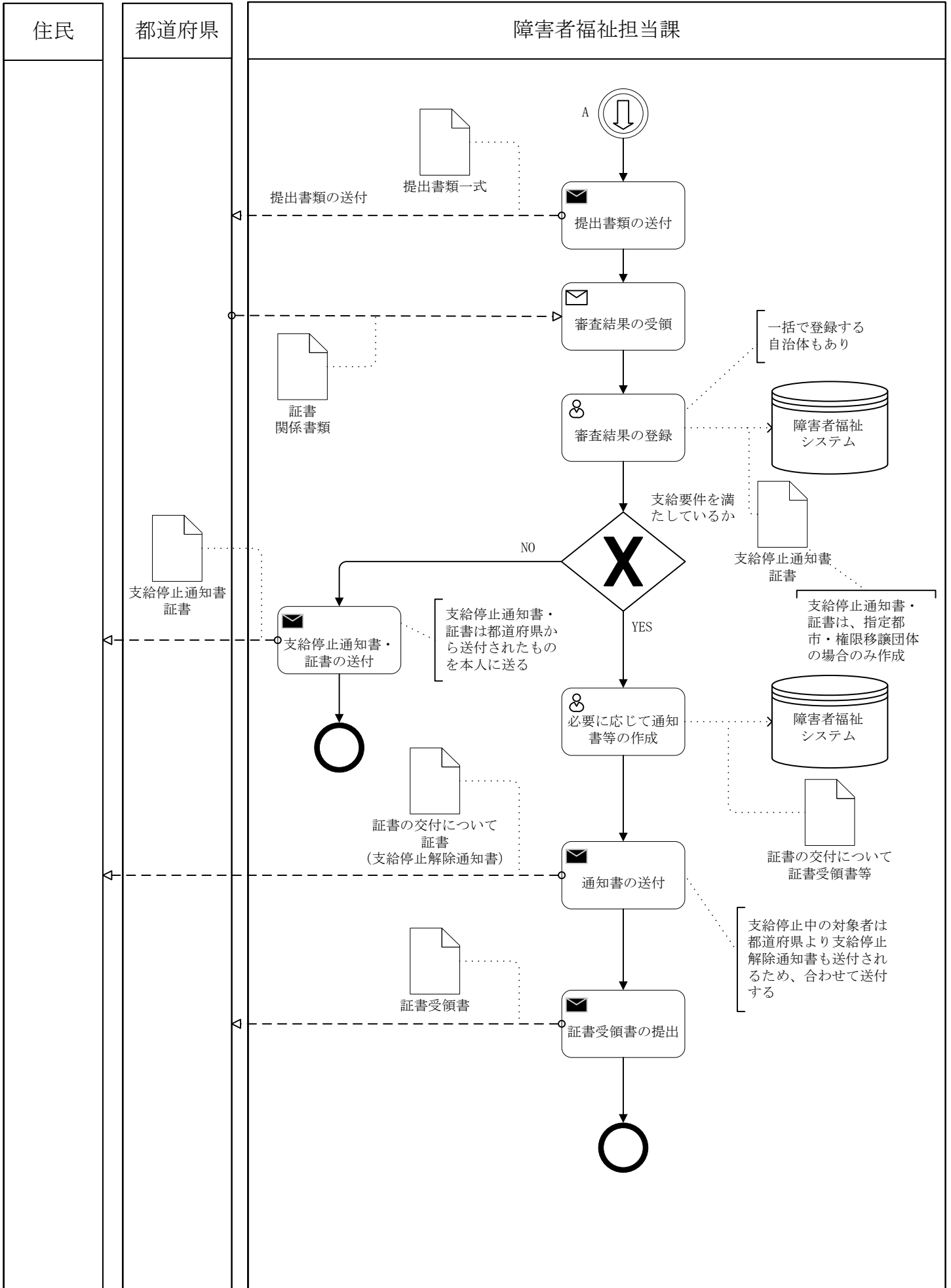

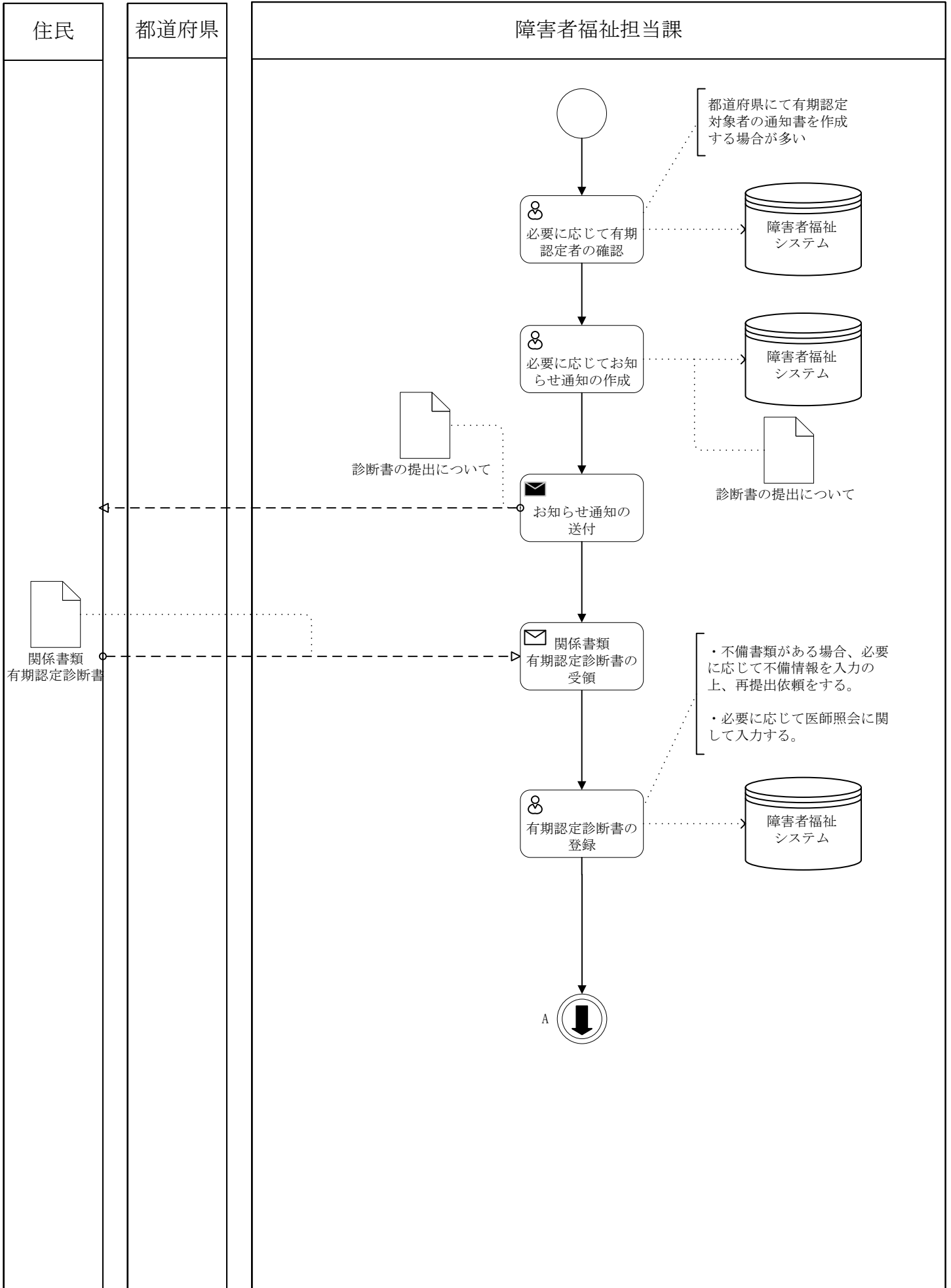

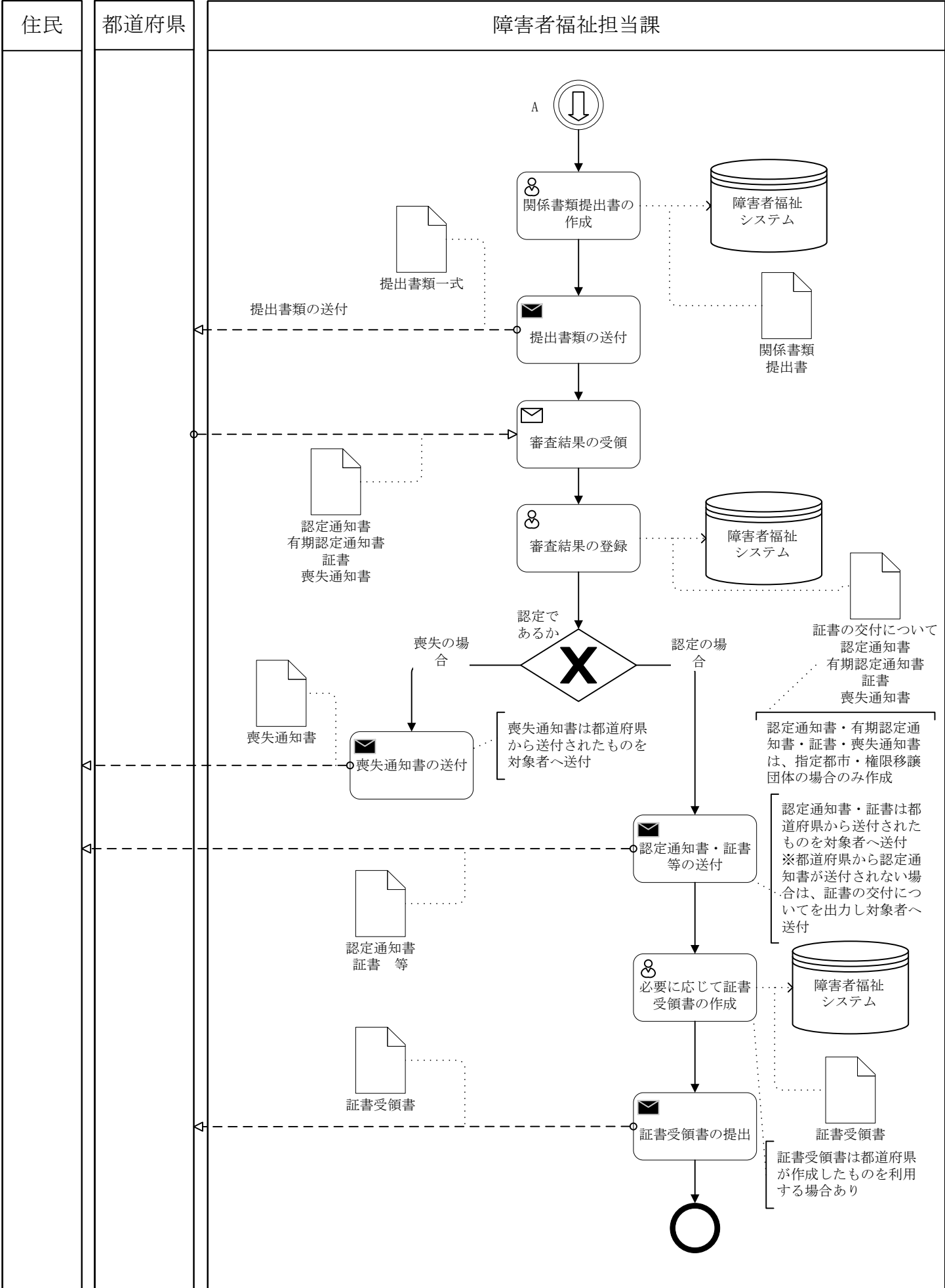

|    |         |     |             |     |                               |
|----|---------|-----|-------------|-----|-------------------------------|
| 区分 | 1 障害者福祉 | 大分類 | 12 特別児童扶養手当 | 小分類 | 05 変更届（氏名・住所・口座・再交付申請・証書亡失届等） |
|----|---------|-----|-------------|-----|-------------------------------|

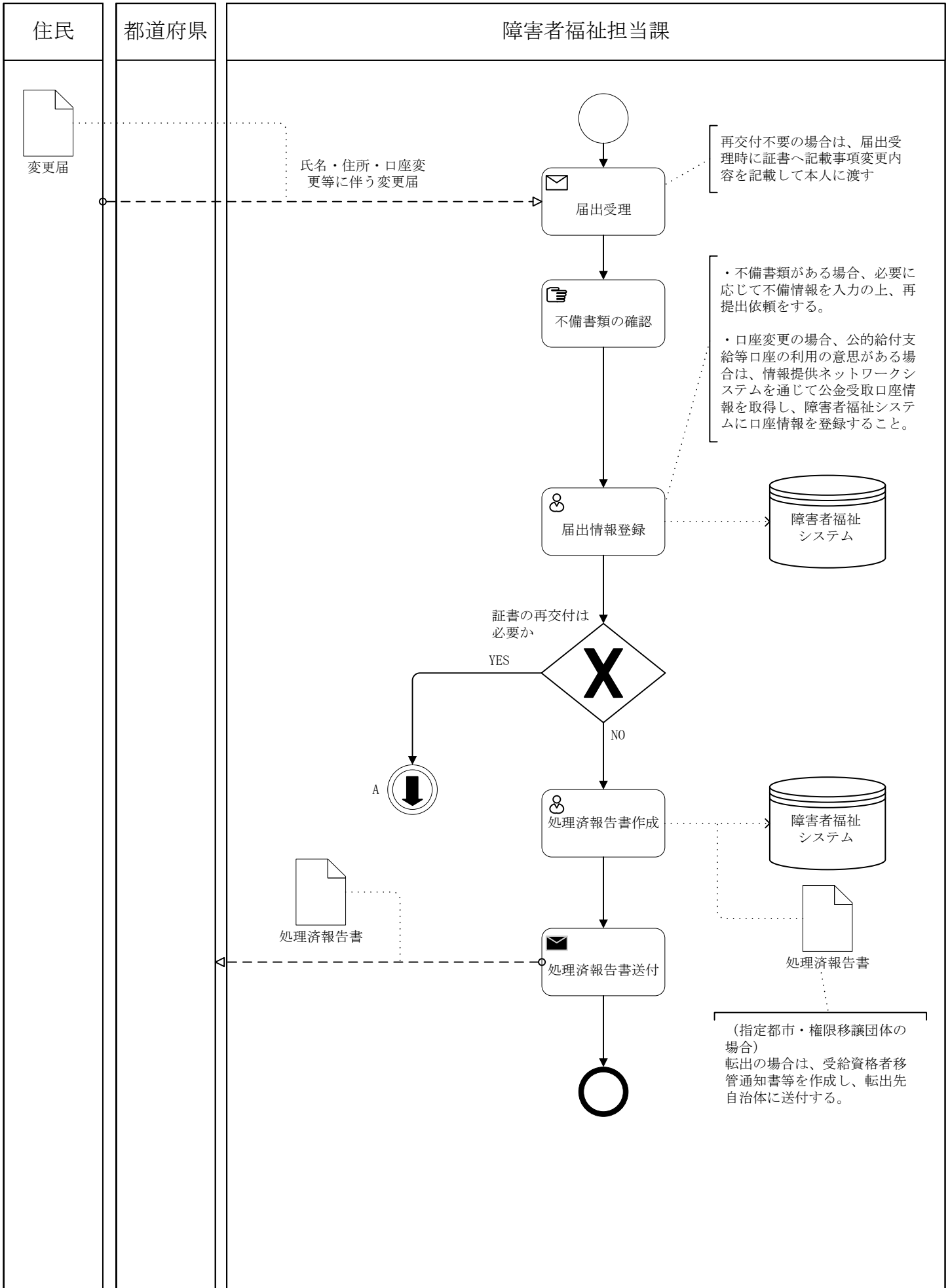

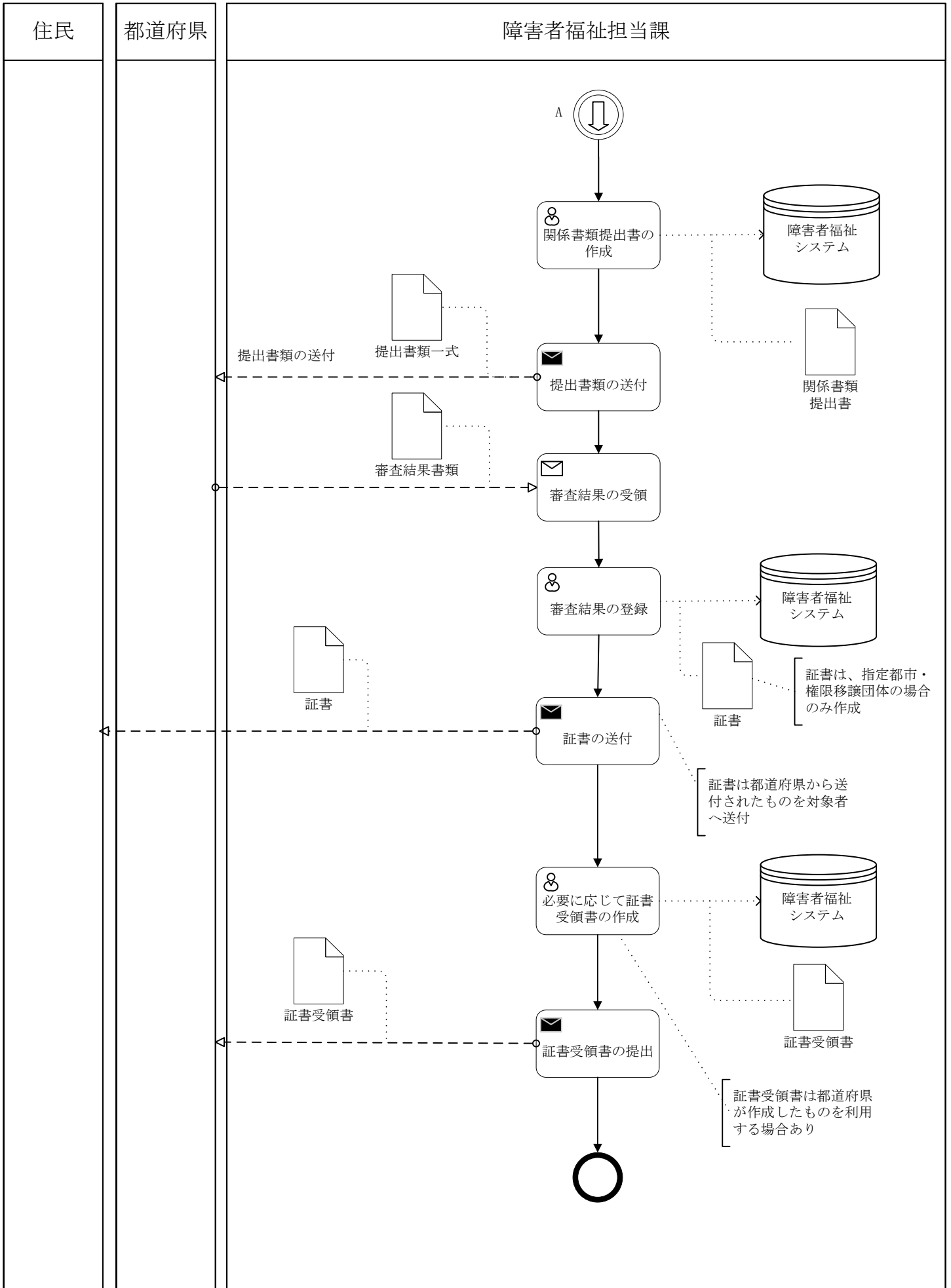



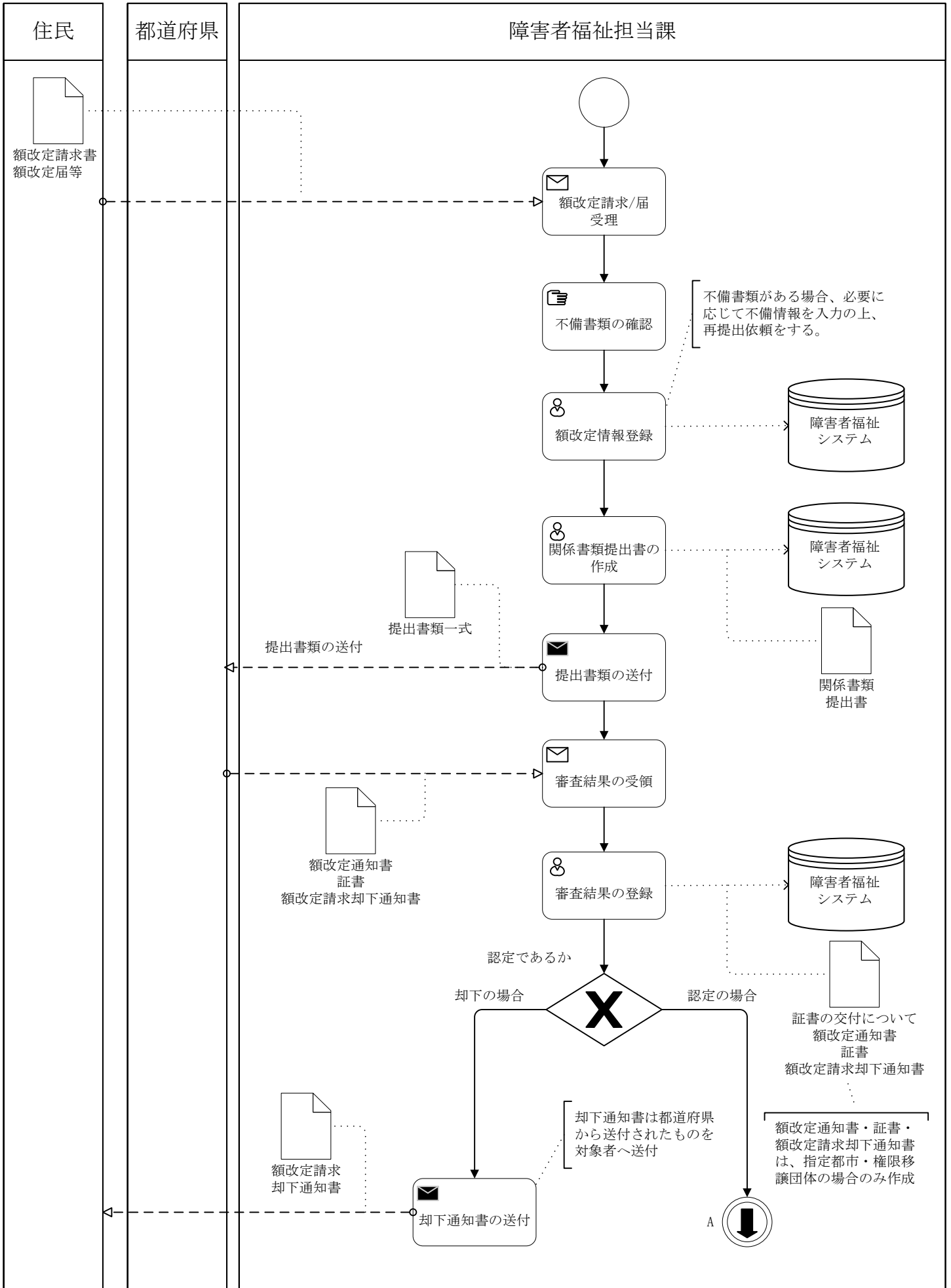

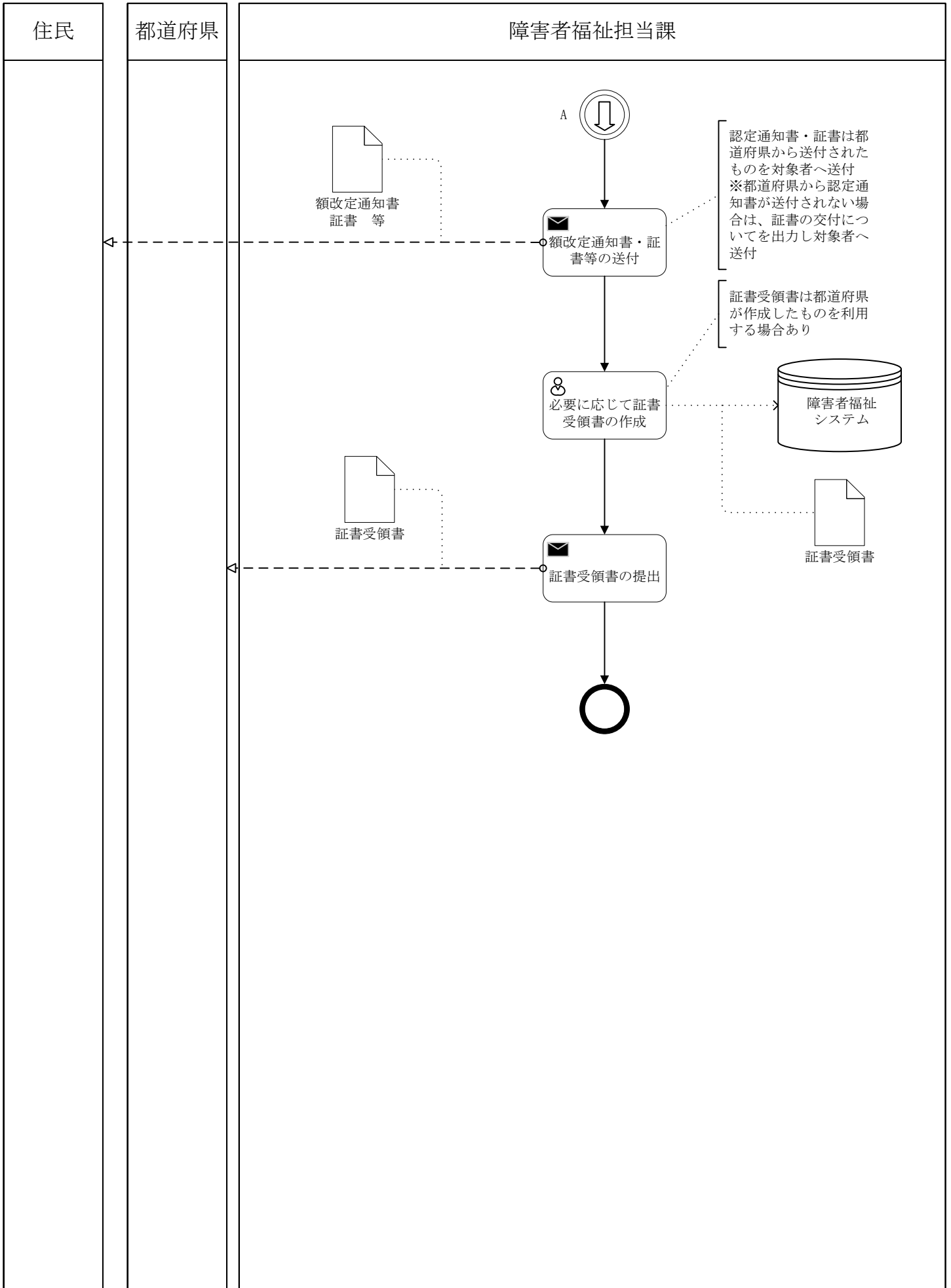

|    |         |     |             |     |         |
|----|---------|-----|-------------|-----|---------|
| 区分 | 1 障害者福祉 | 大分類 | 12 特別児童扶養手当 | 小分類 | 07 年齢到達 |
|----|---------|-----|-------------|-----|---------|

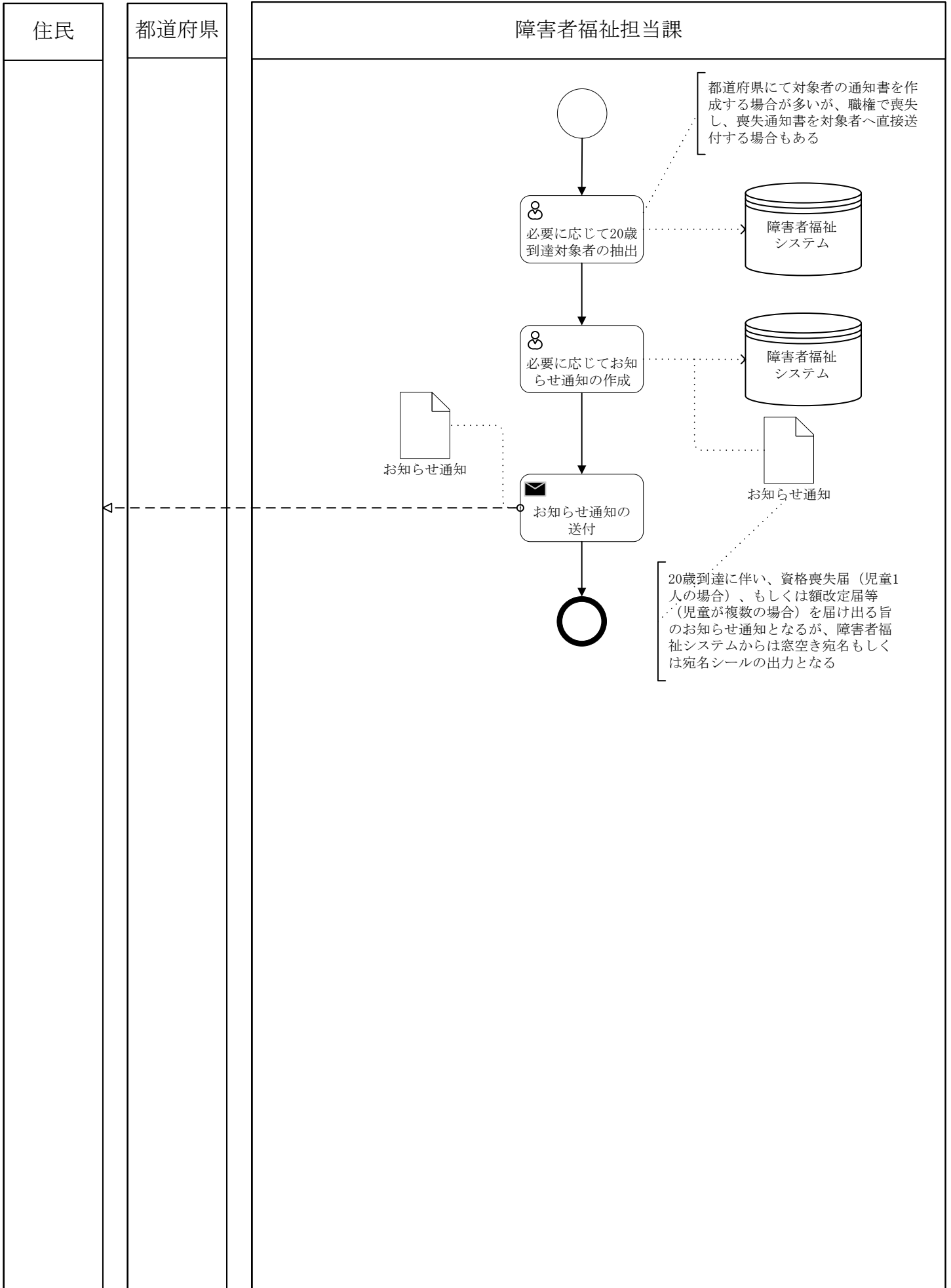

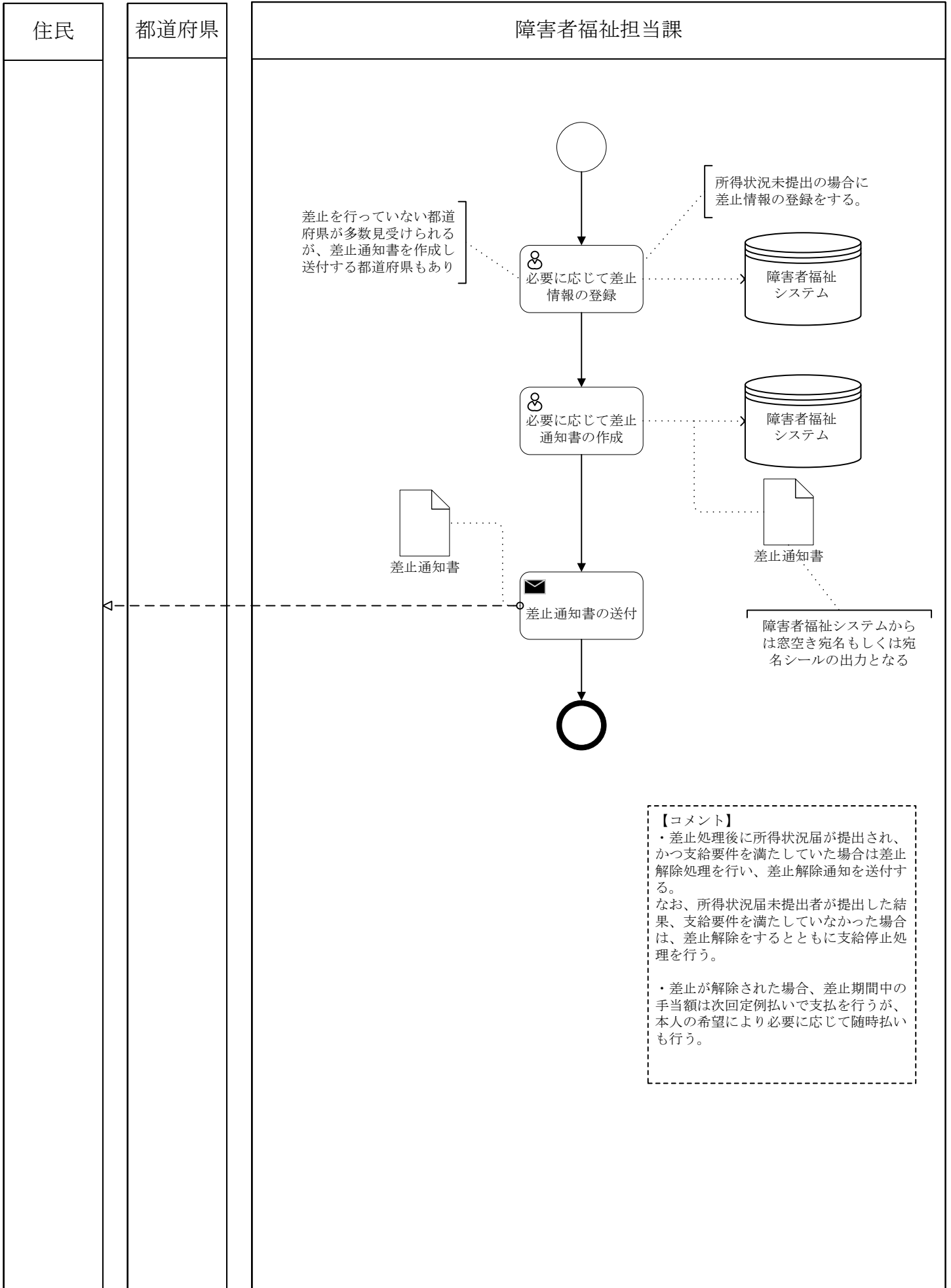

住民

厚生労働省

