

(別紙 1) 業務フロー

業務フロー一覧（58フロー）

区分	大分類	小分類	頁番号
1 介護保険	02 被保険者資格	01 住民情報異動等に伴う資格異動	1
		02 被保険者証等再交付	
		03 自市町村住所地特例者把握	
		04 他市町村住所地特例者把握	
		05 適用除外施設入所者把握	
	03 保険料賦課	02 仮算定	6
		03 仮徴収額変更	
		04 本算定	
		05 月割賦課	
		06 口座振替依頼	
07 代理納付管理			
08 減免・猶予管理			
08 減免・猶予管理			
04 保険料収納	02 収納消込（自主納付・代理納付）	16	
	03 収納消込（口座振替）		
	04 収納消込（特別徴収）		
	05 還付・充当		
	06 納付証明書発行		
	06 納付証明書発行		
05 滞納管理	02 督促	22	
	03 催告・猶予措置		
	04 滞納処分		
	04 滞納処分		
06 受給者管理	01 減免／減額認定	27	
	02 負担割合		
	03 給付制限（償還払い化）		
	04 給付制限（一時差止）		
	05 給付制限（給付額減額）		
	06 給付制限（2号被保険者における保険給付差止）		
	07 国保連受給者異動		
07 認定管理	01 要介護／要支援認定申請	38	
	02 認定調査		
	03 意見書作成		
	04 一次判定／二次判定（審査会）		
	05 要介護／要支援認定		
	06 認定更新勧奨		
	07 情報提供		
	08 処分延期通知		
	09 謝金・報酬支払		
08 給付管理	02 居宅届出	47	
	03 償還（住宅改修費）		
	04 償還（福祉用具購入費）		
	05 償還（その他償還）		
	06 高額サービス費		
	07 支払通知		
	08 給付実績		
	09 高額合算（交付申請）		
	10 高額合算（支給申請）		
	11 介護給付費通知		
	11 介護給付費通知		
09 統計・報告等	01 報告資料作成	63	
10 総合事業	02 事業対象者	64	
	03 負担割合		
	04 国保連受給者異動		
	05 介護予防ケアマネジメント届出		
	06 償還（介護予防・日常生活支援総合事業費）		
	07 高額介護予防サービス費相当事業		
	08 支払通知		
	09 給付実績（介護予防・日常生活支援総合事業費）		
	10 高額医療合算介護予防サービス費相当事業（交付申請）		
	11 高額医療合算介護予防サービス費相当事業（支給申請）		
	12 介護給付費通知		

※ 大分類01は、「介護保険共通」のため対象となる業務フローは無し。

※ 大分類03（保険料賦課）、04（保険料収納）、05（滞納管理）、08（給付管理）、10（総合事業）における小分類01は、各大分類の共通となる業務のため対象となる業務フローは無し。

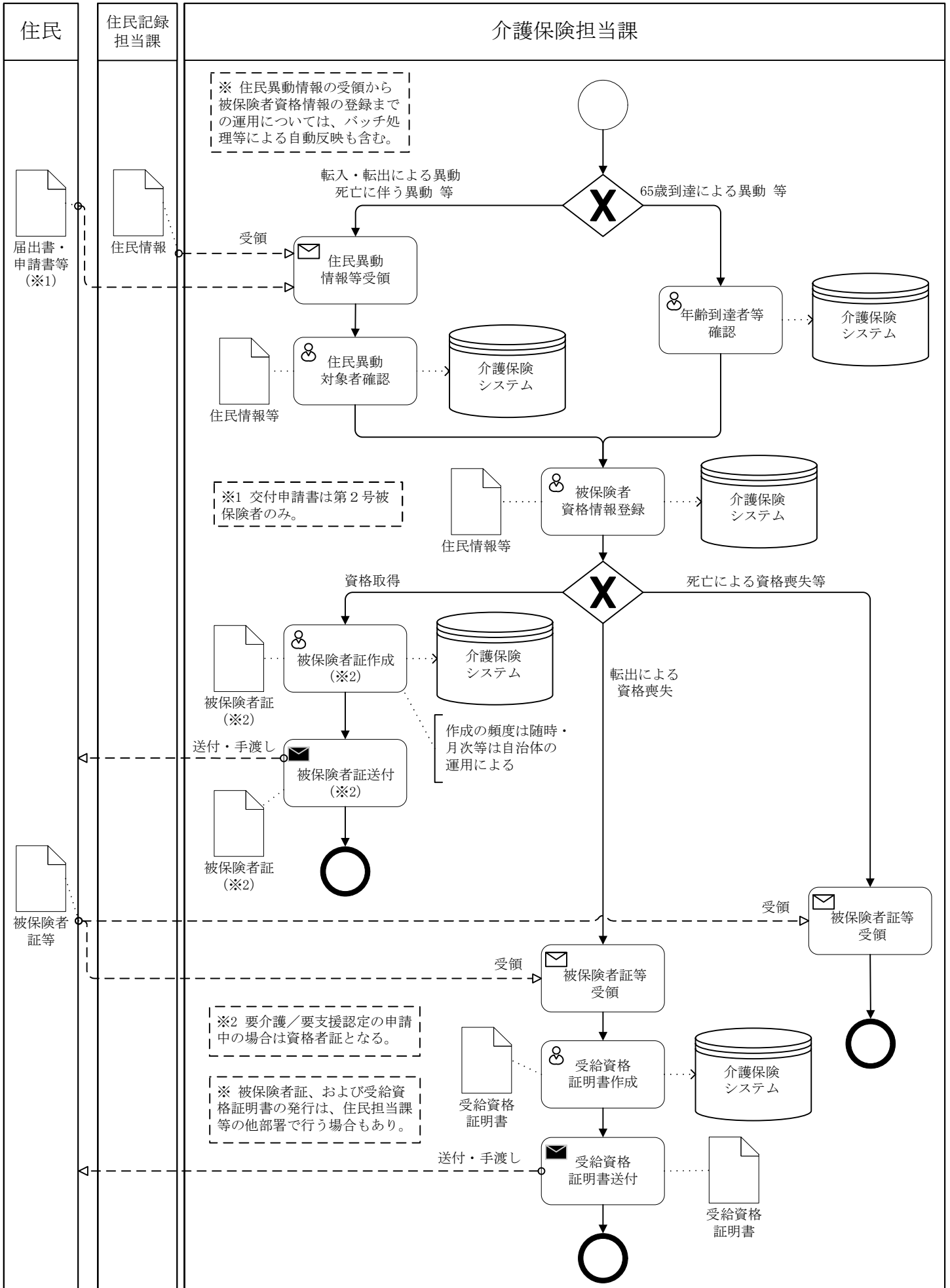

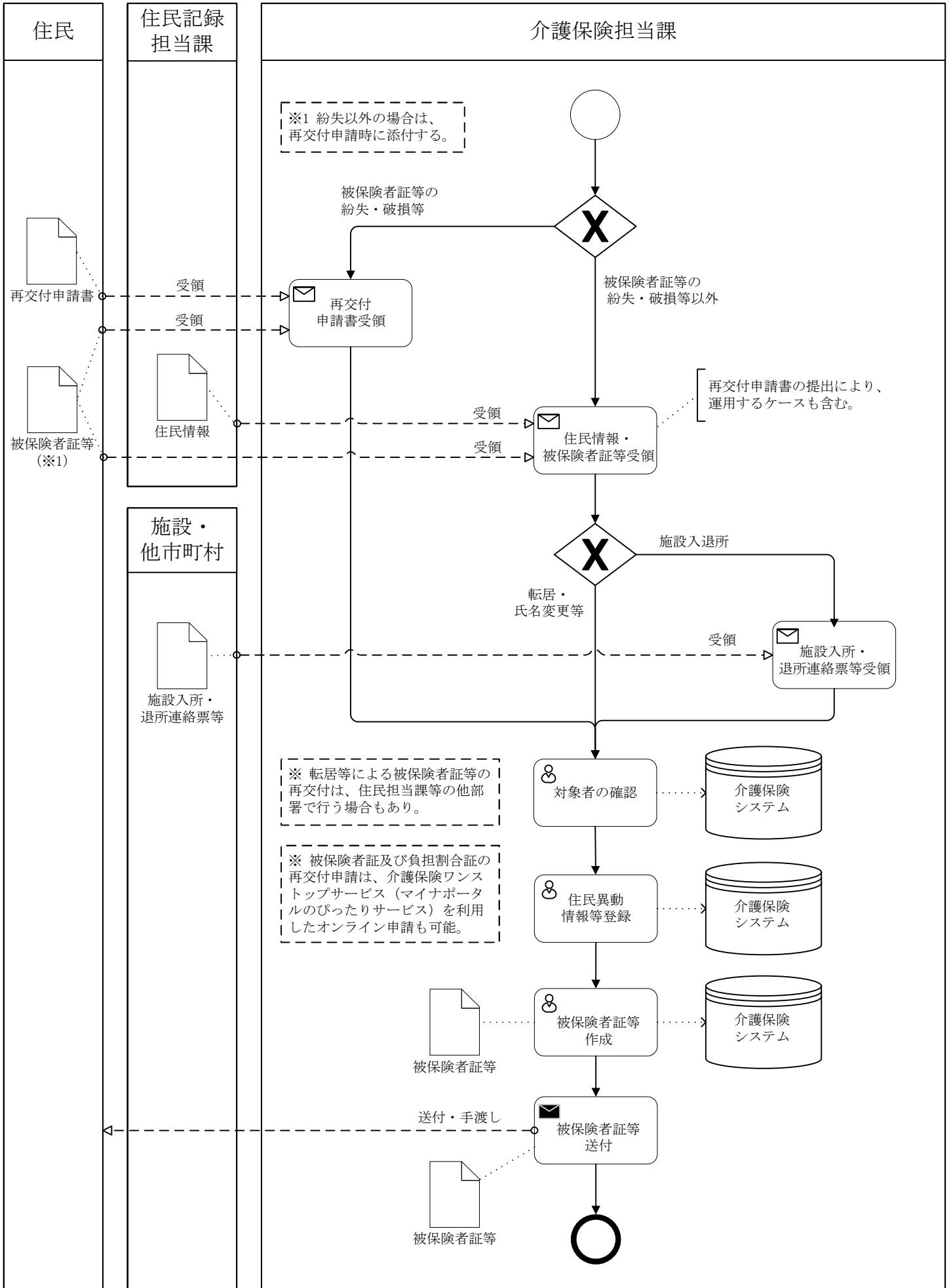

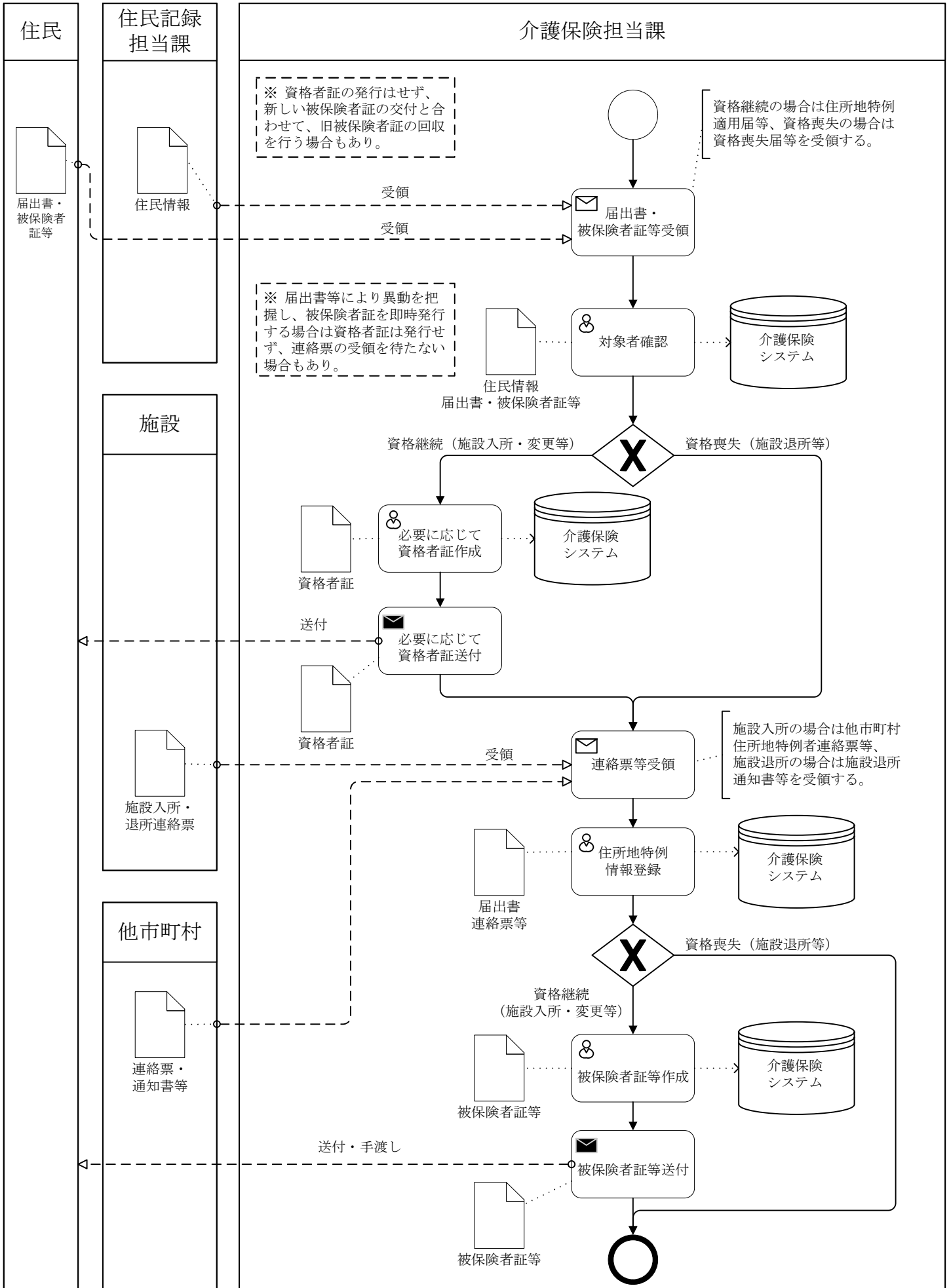

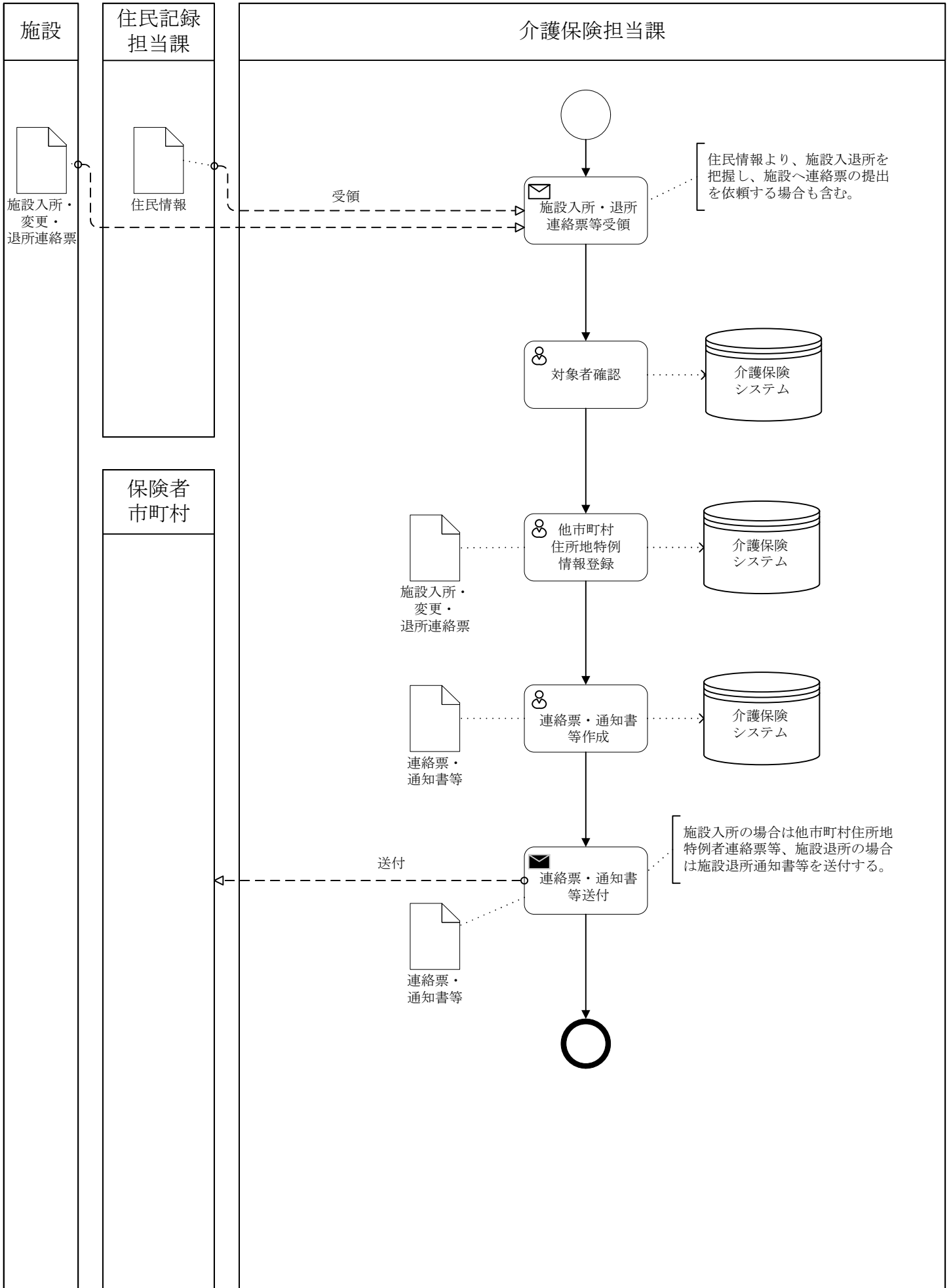

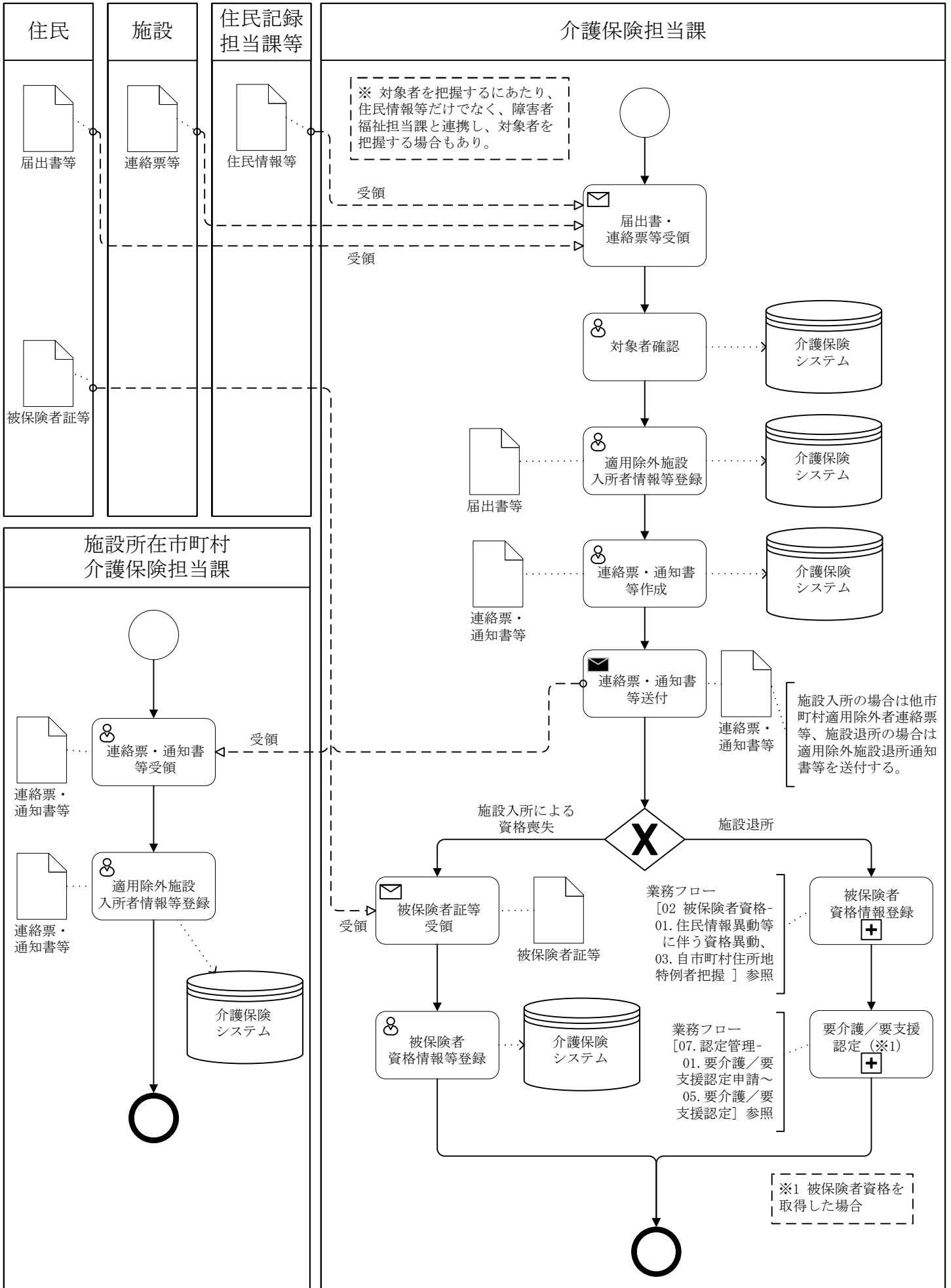

住民

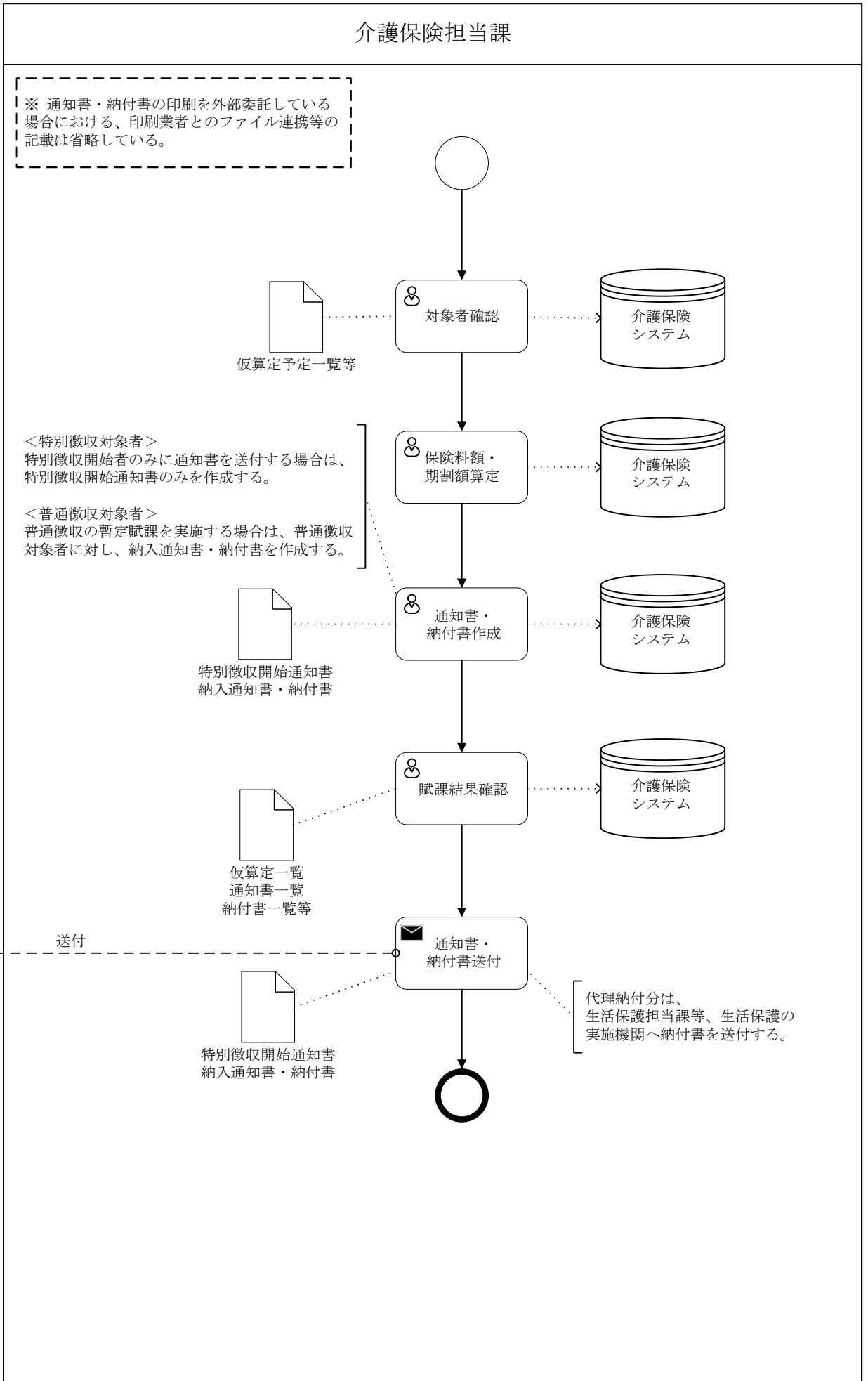

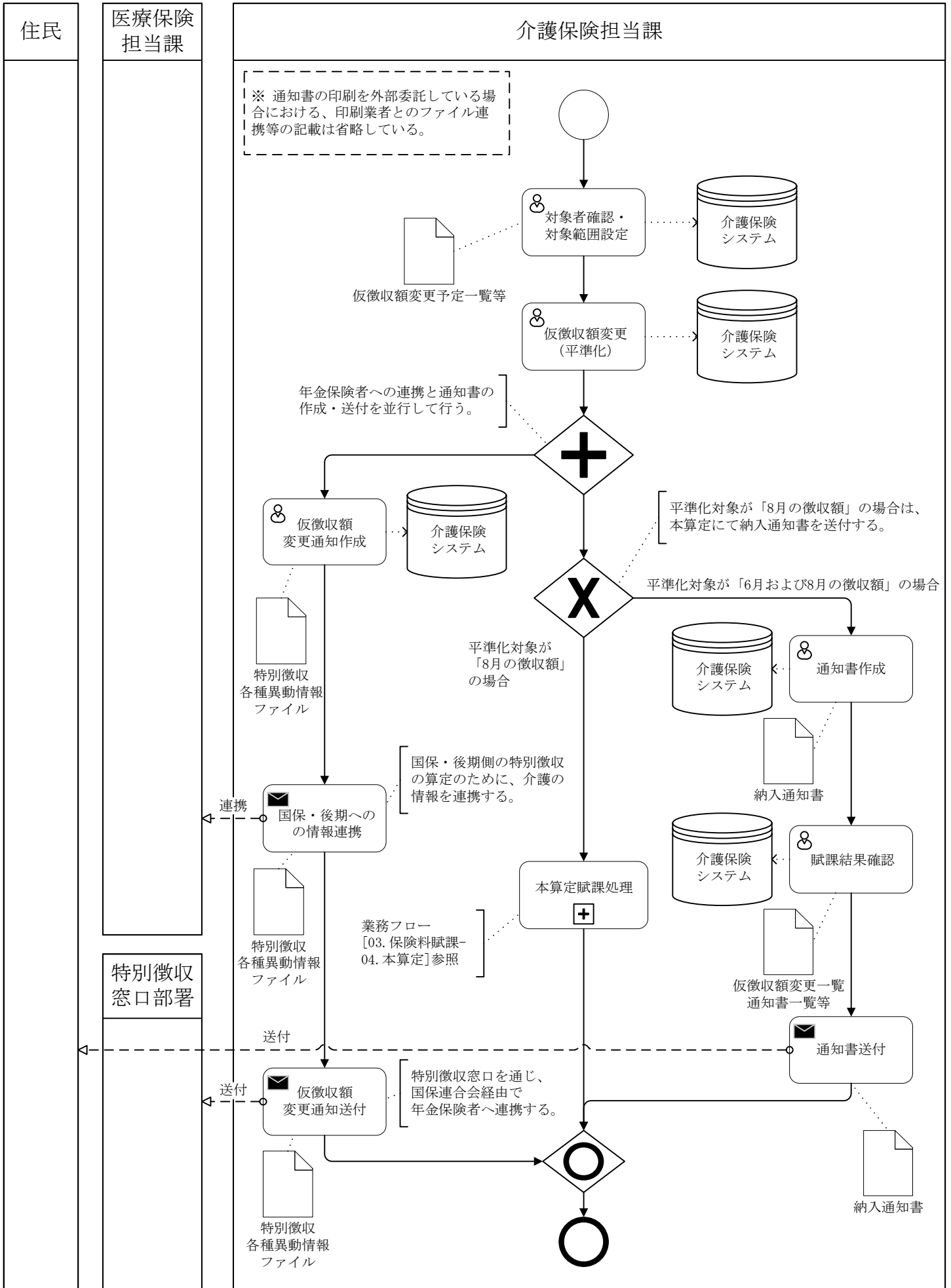

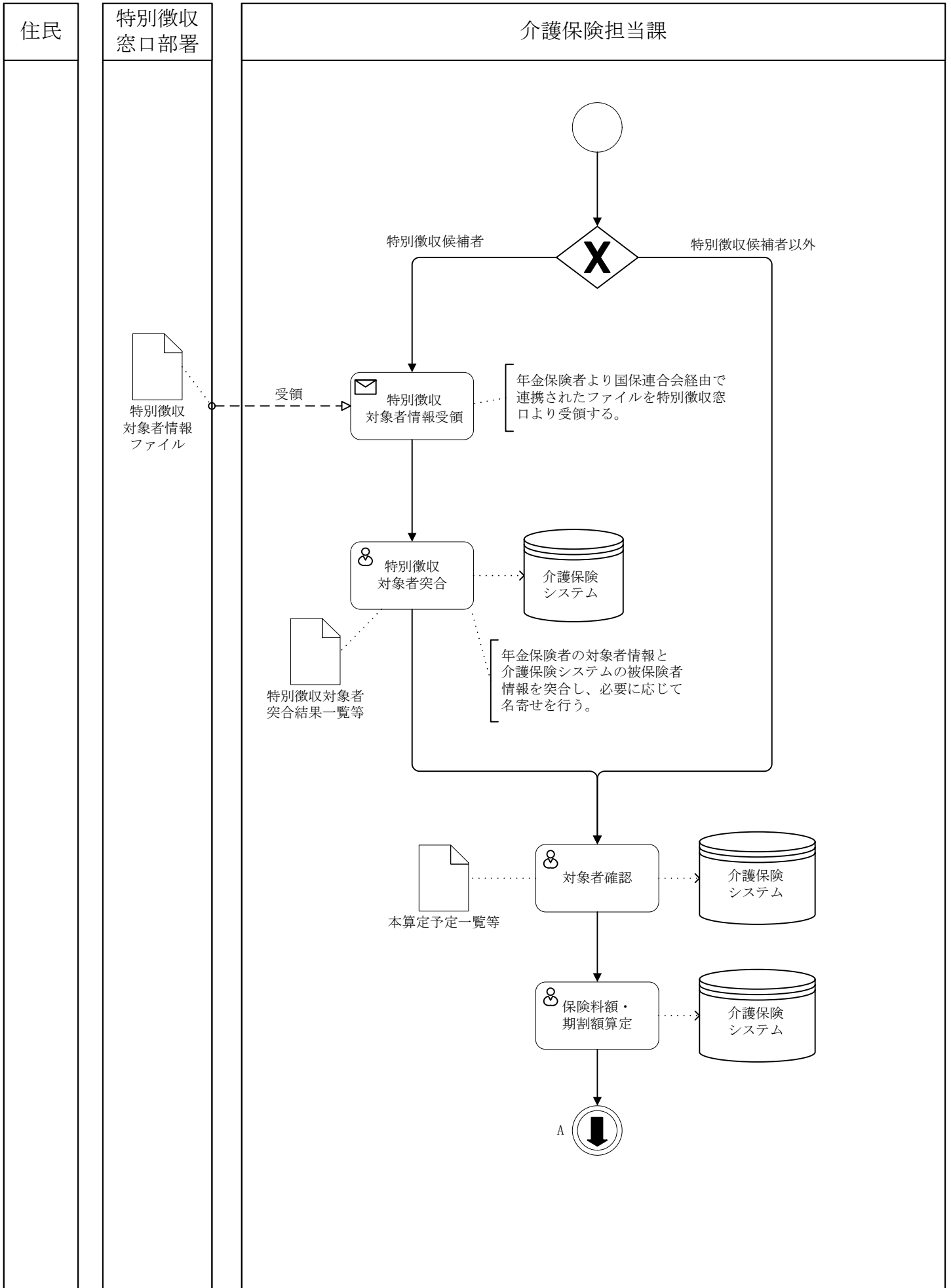

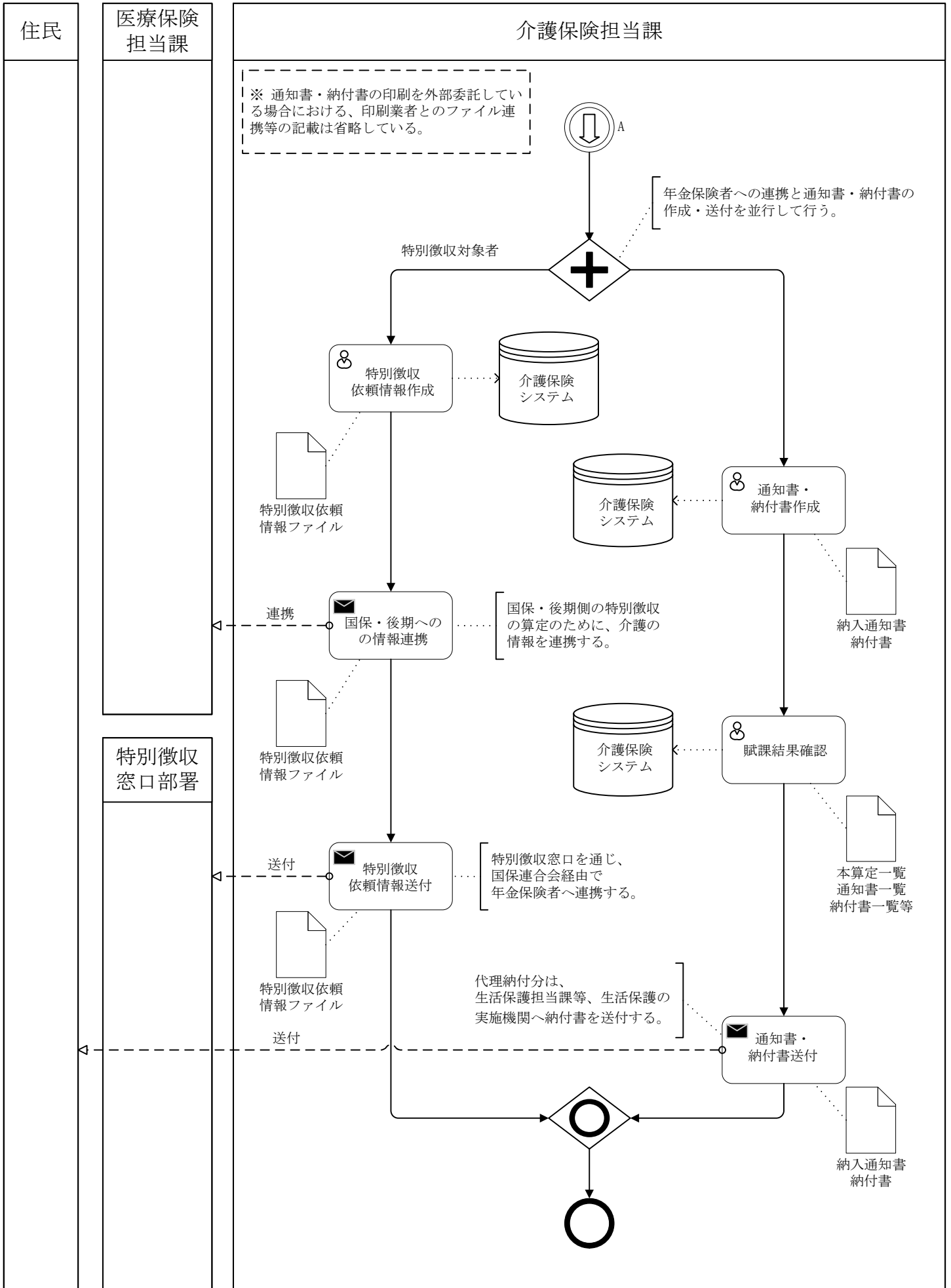

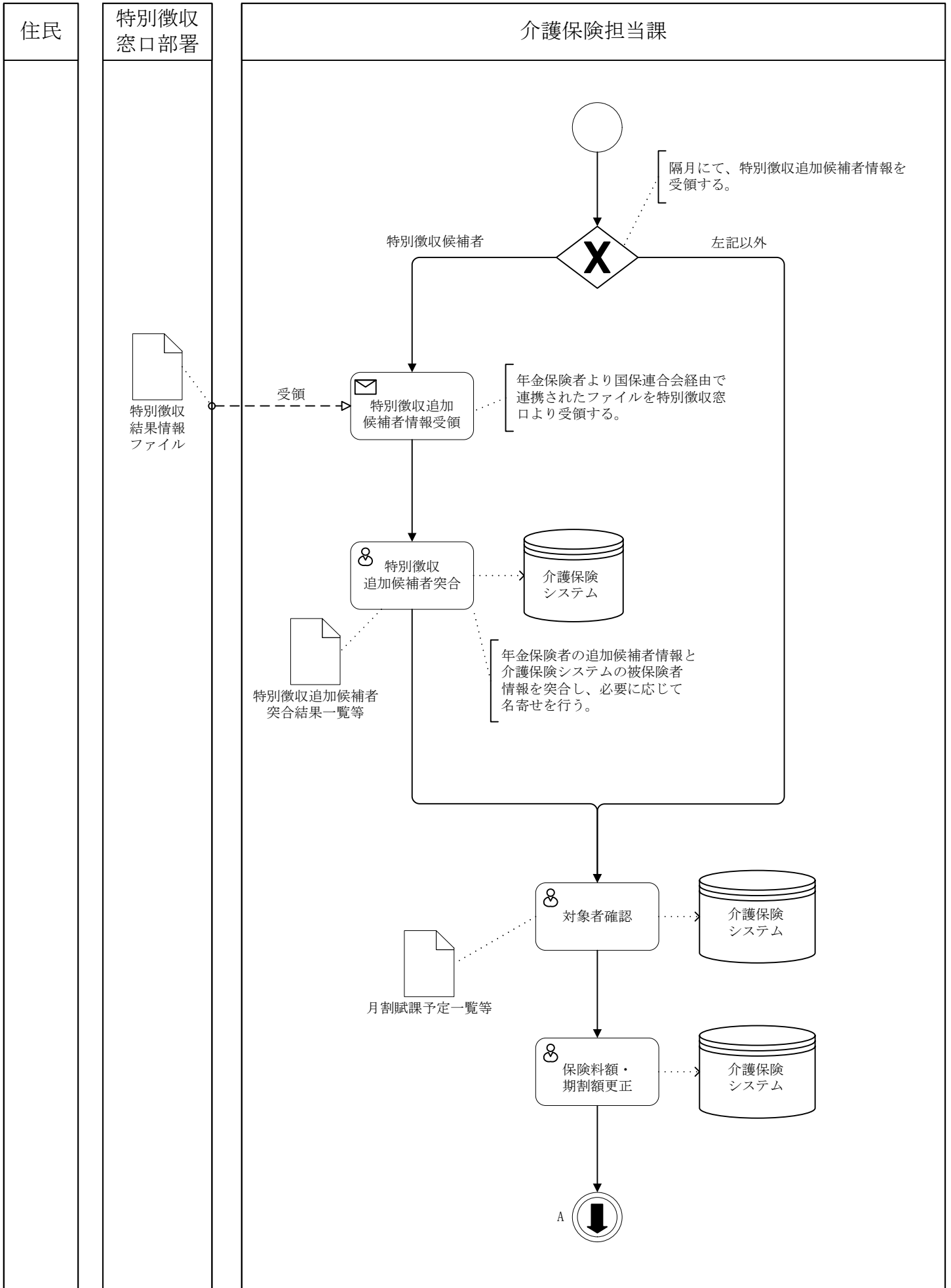

区分	1 介護保険	大分類	03 保険料賦課	小分類	05 月割賦課
----	--------	-----	----------	-----	---------

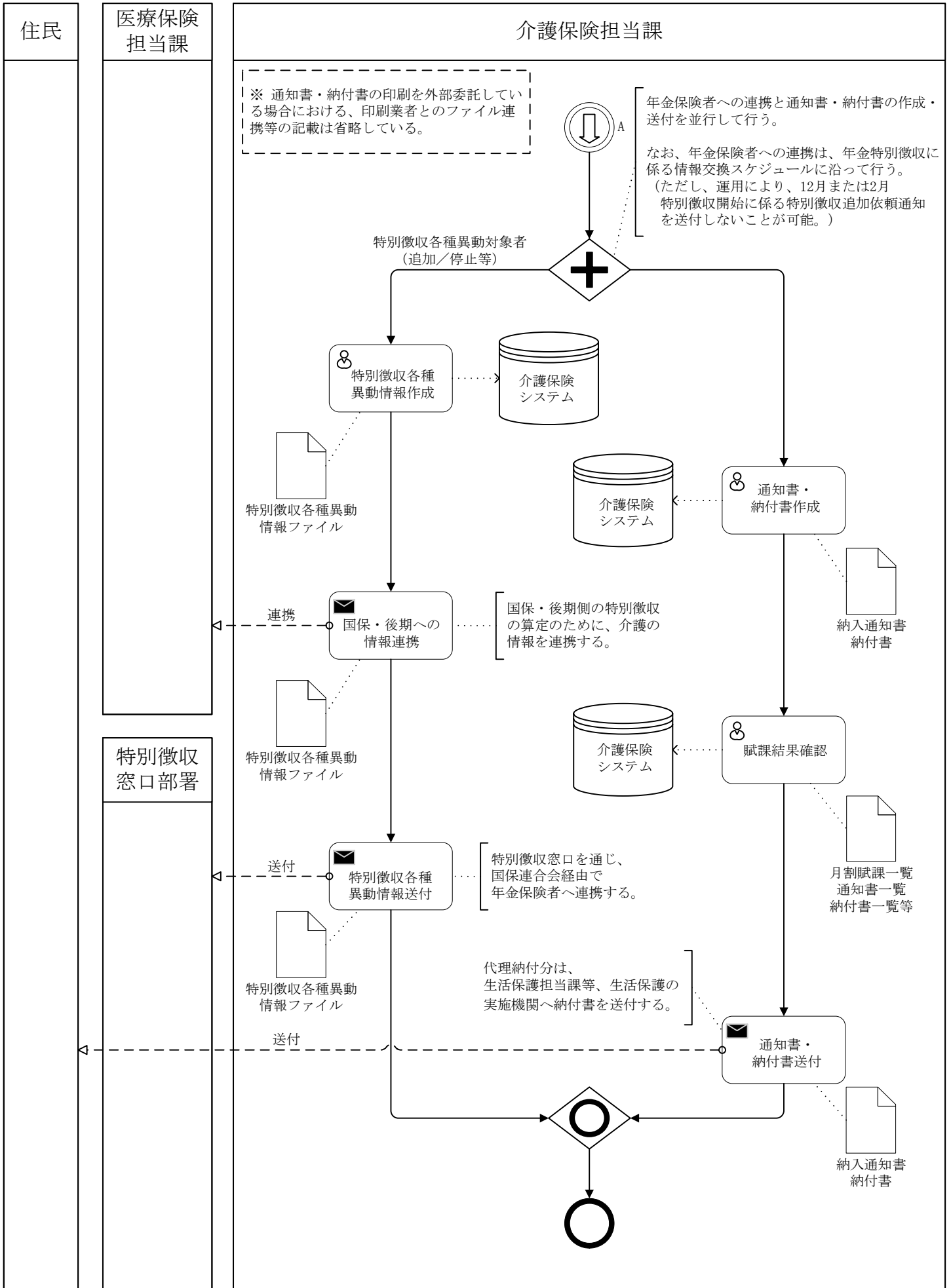

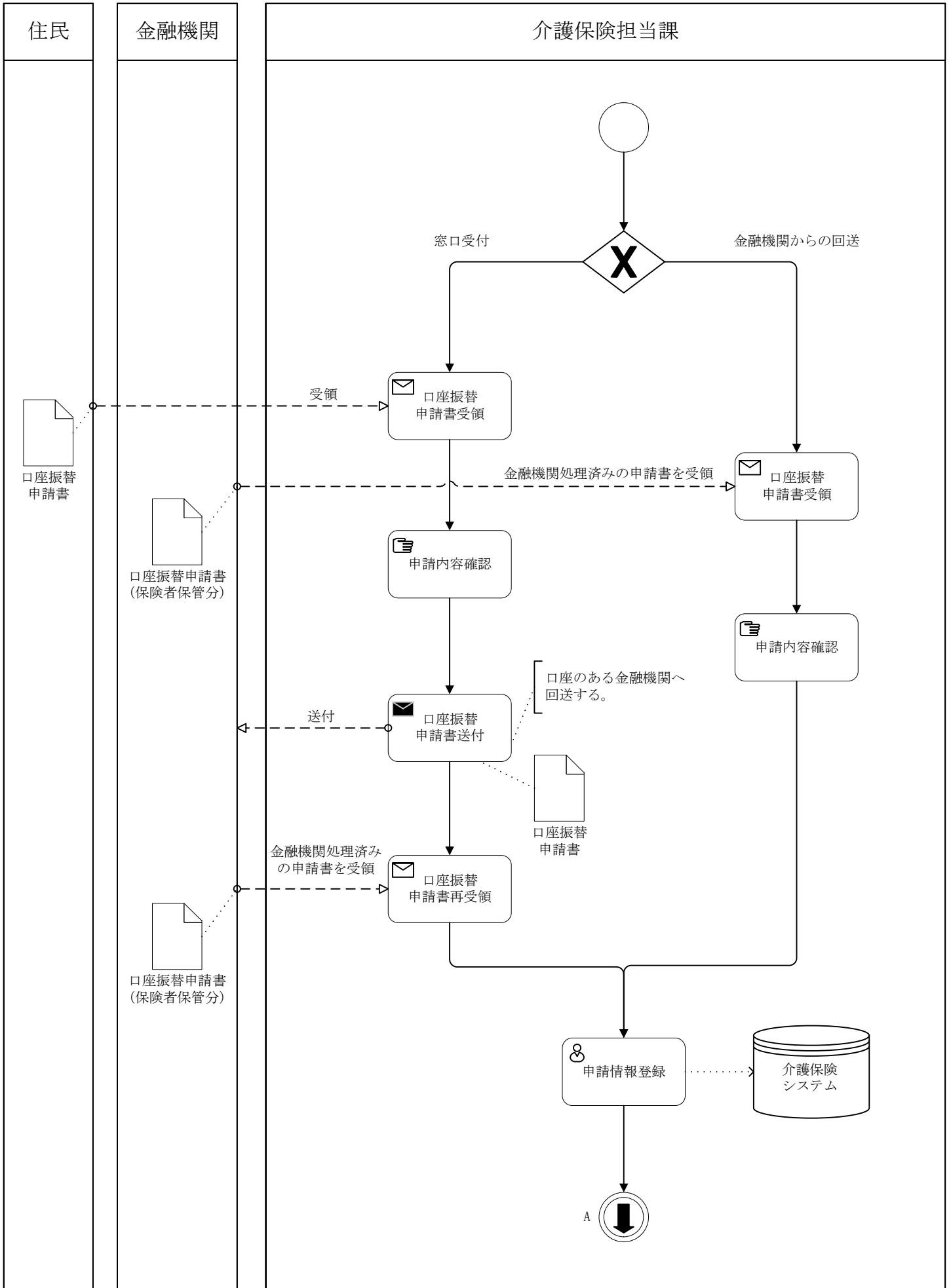

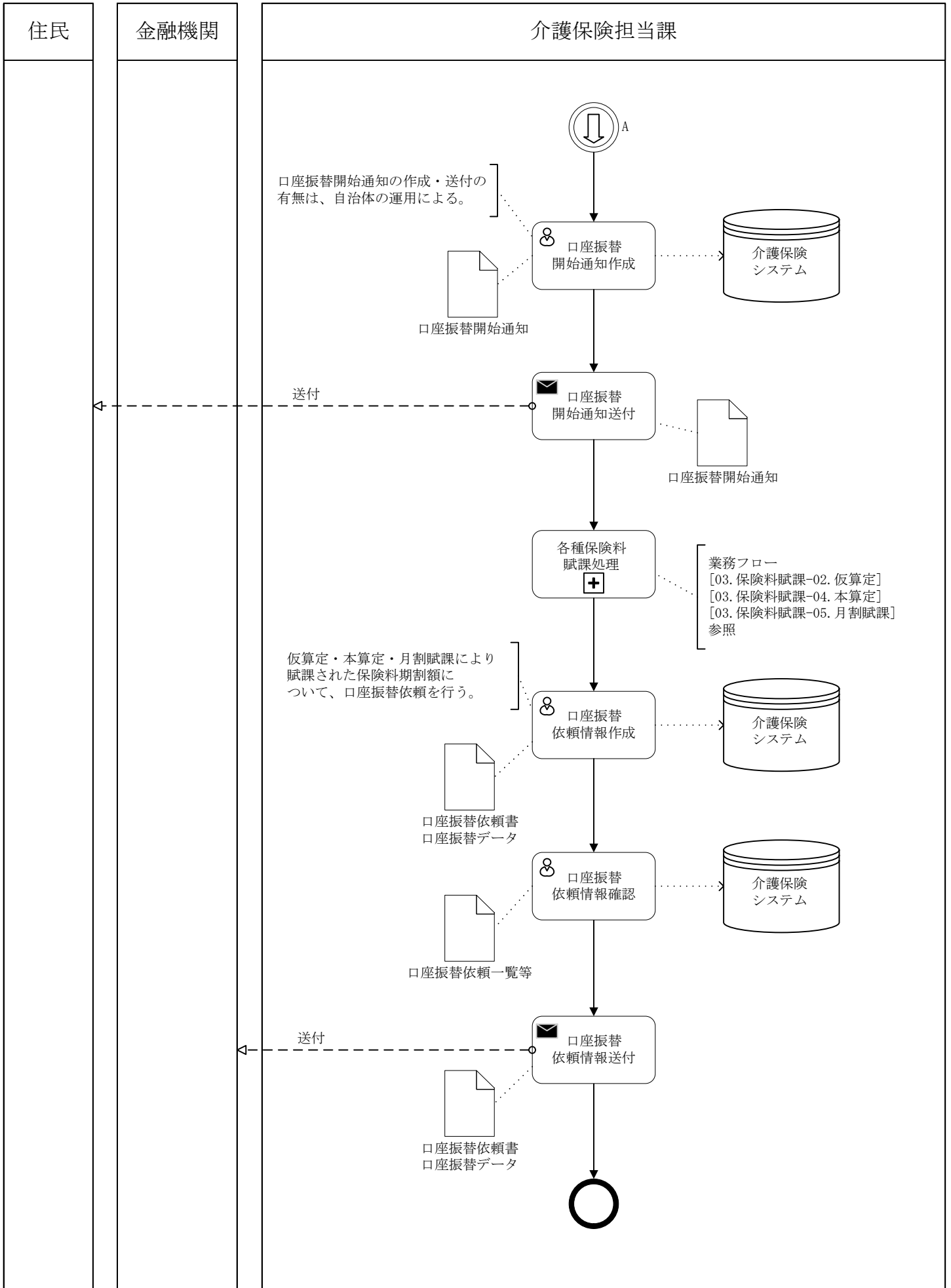

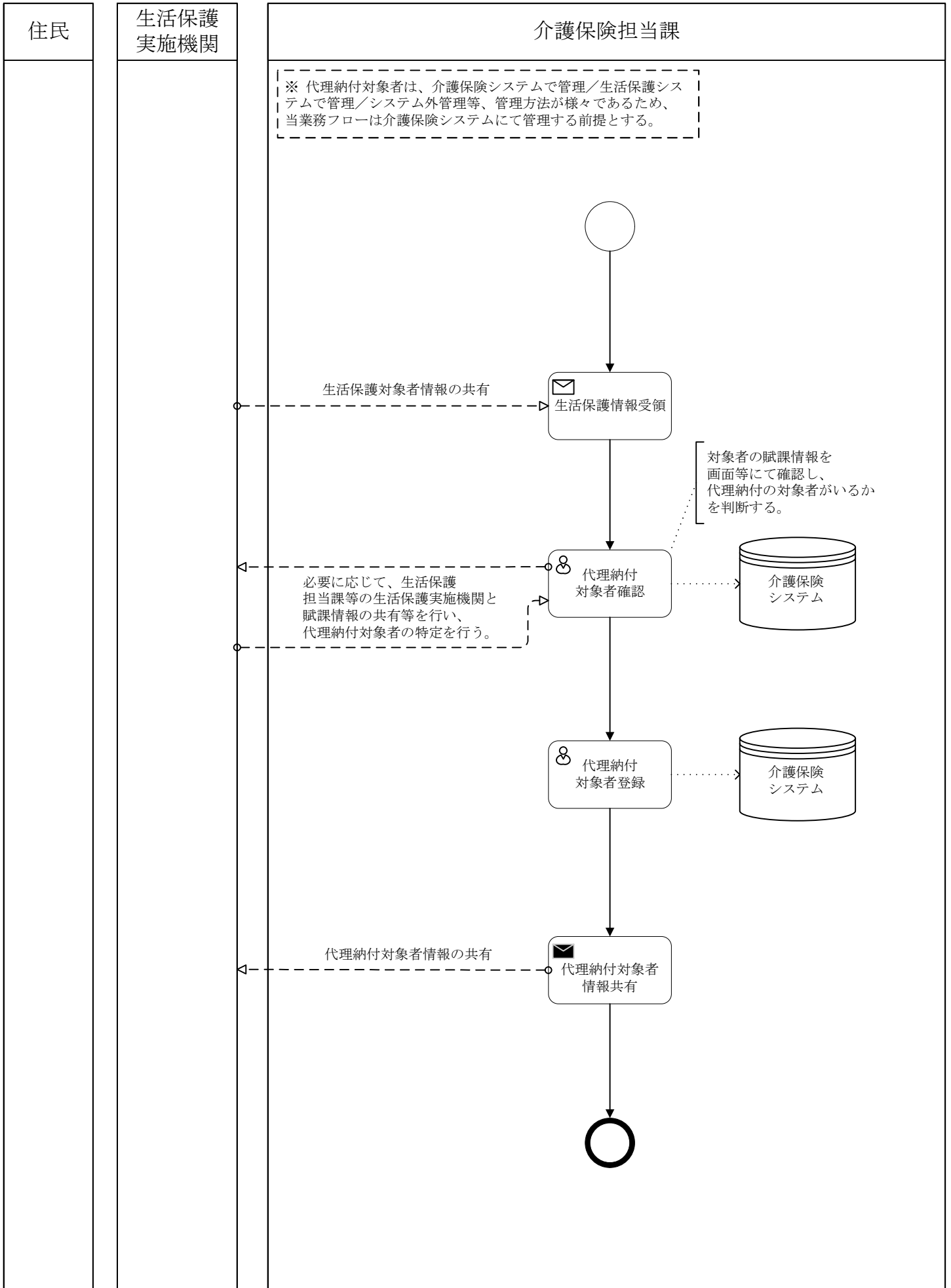

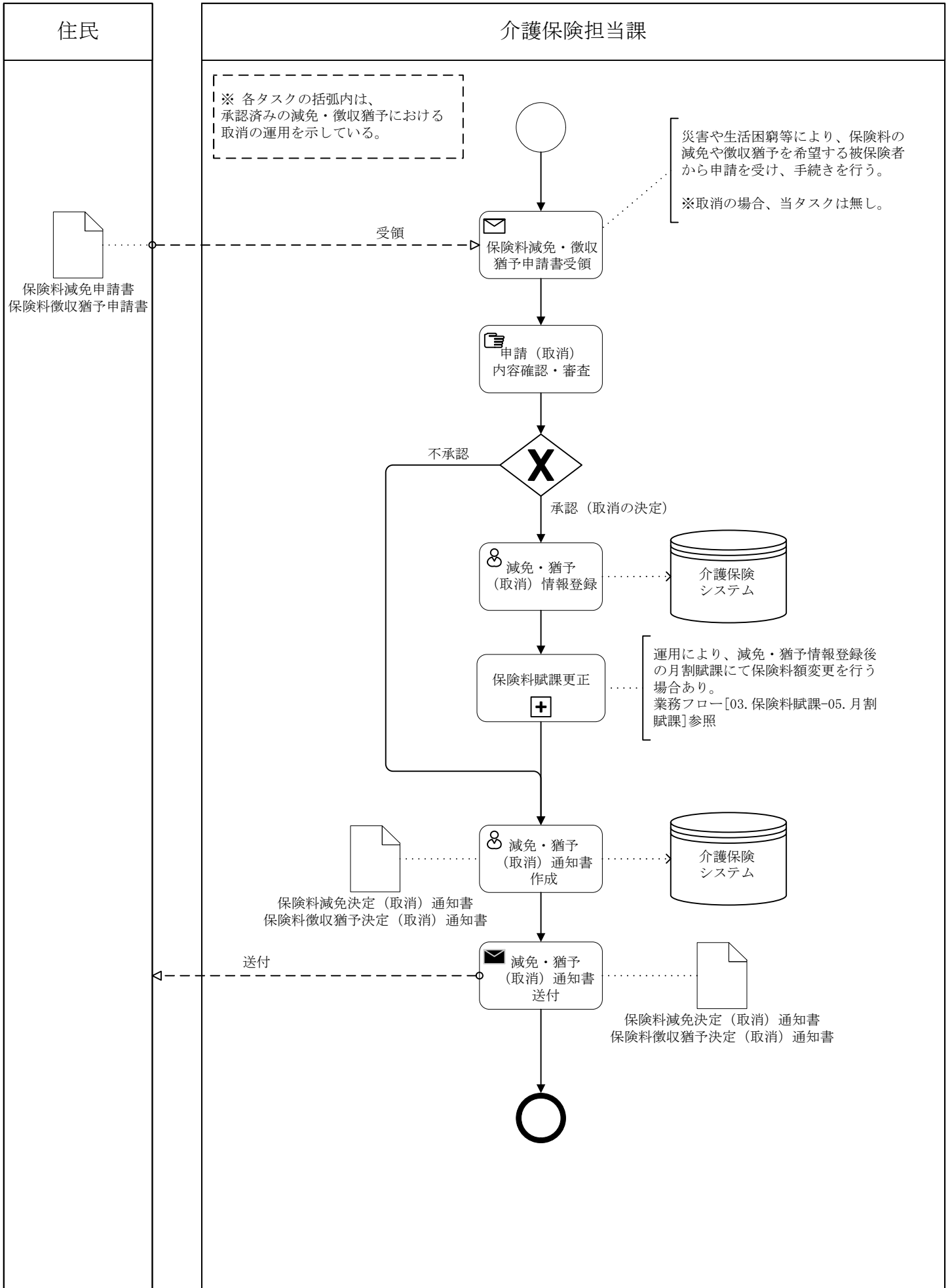

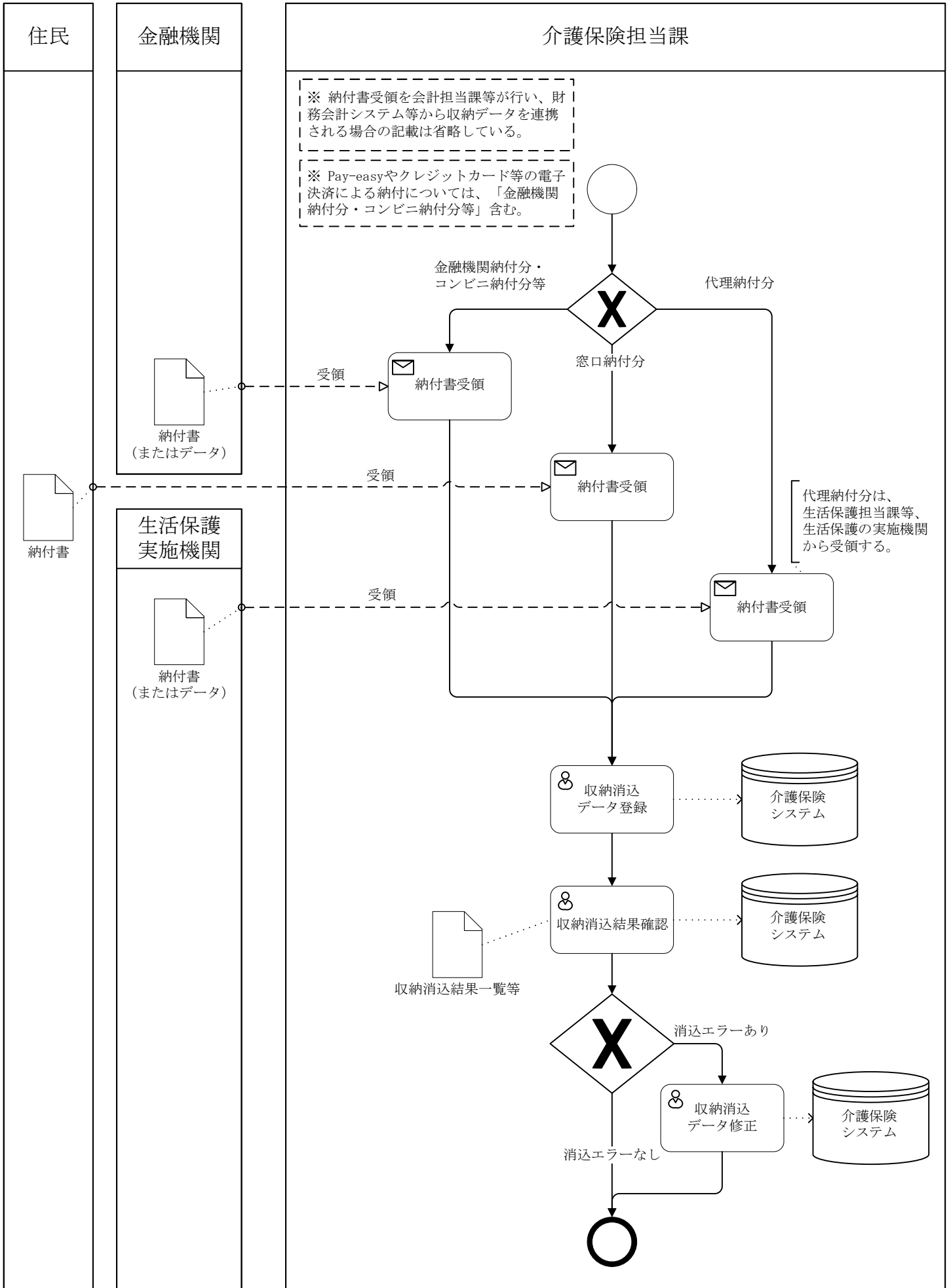

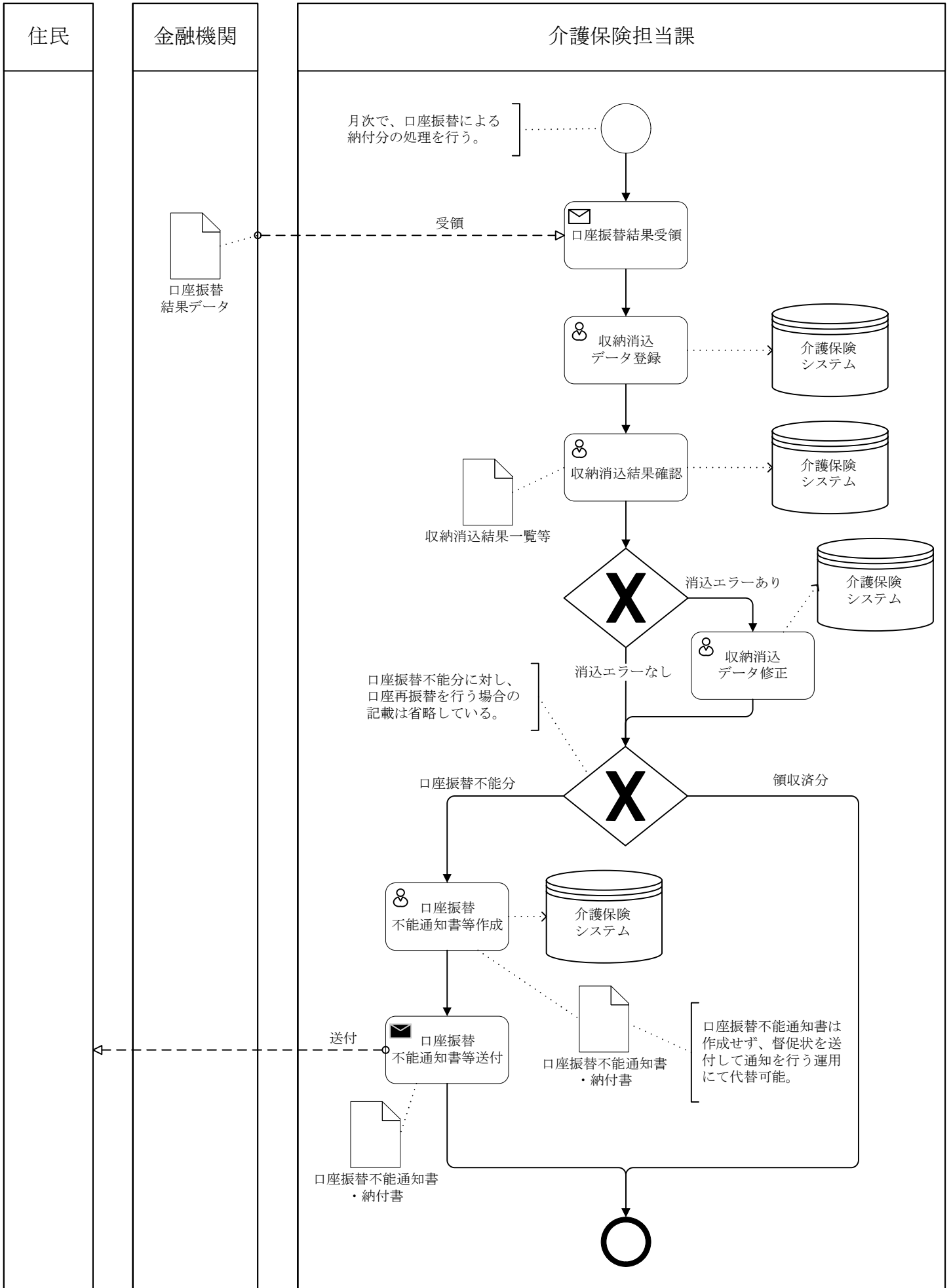

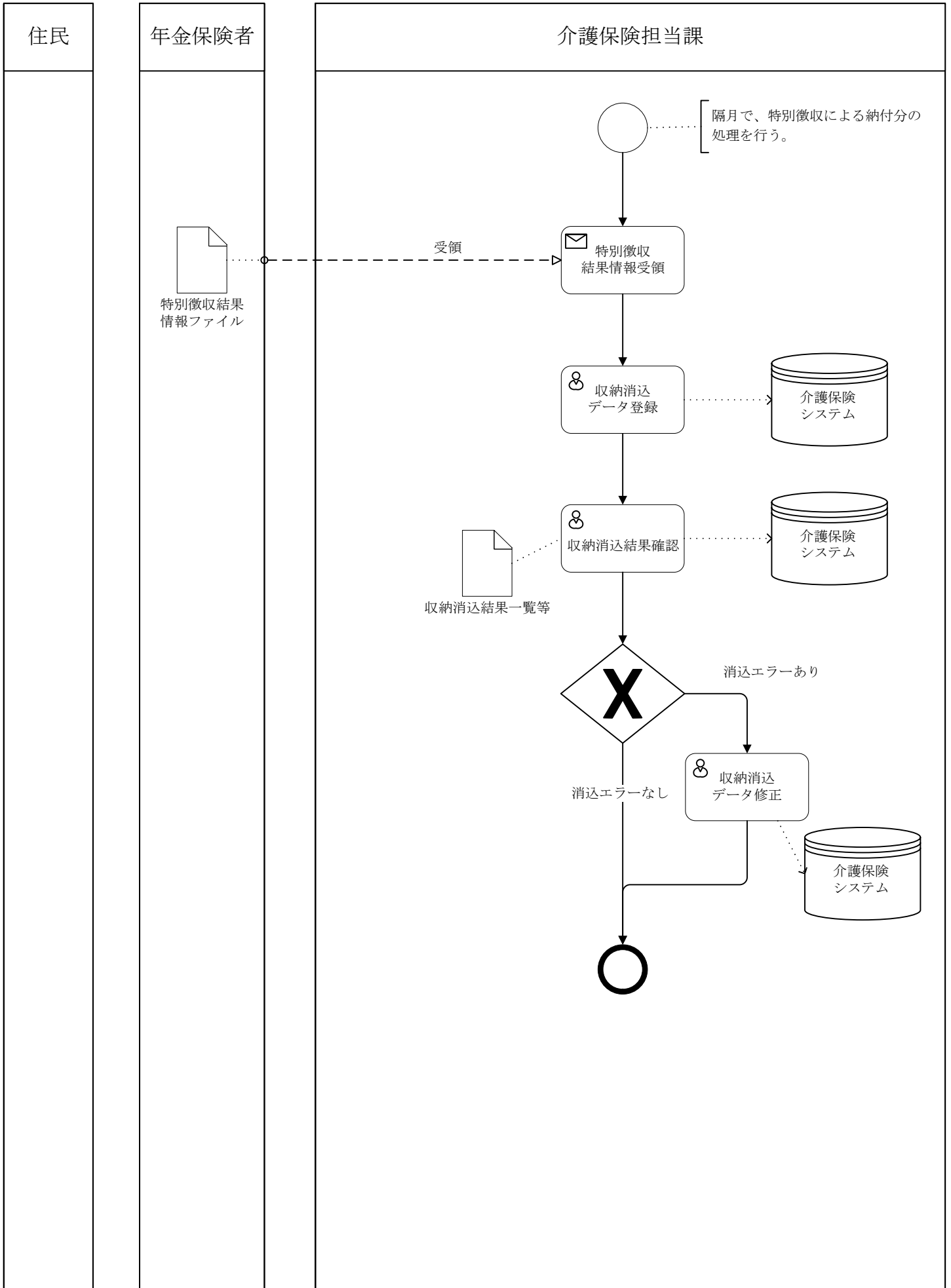

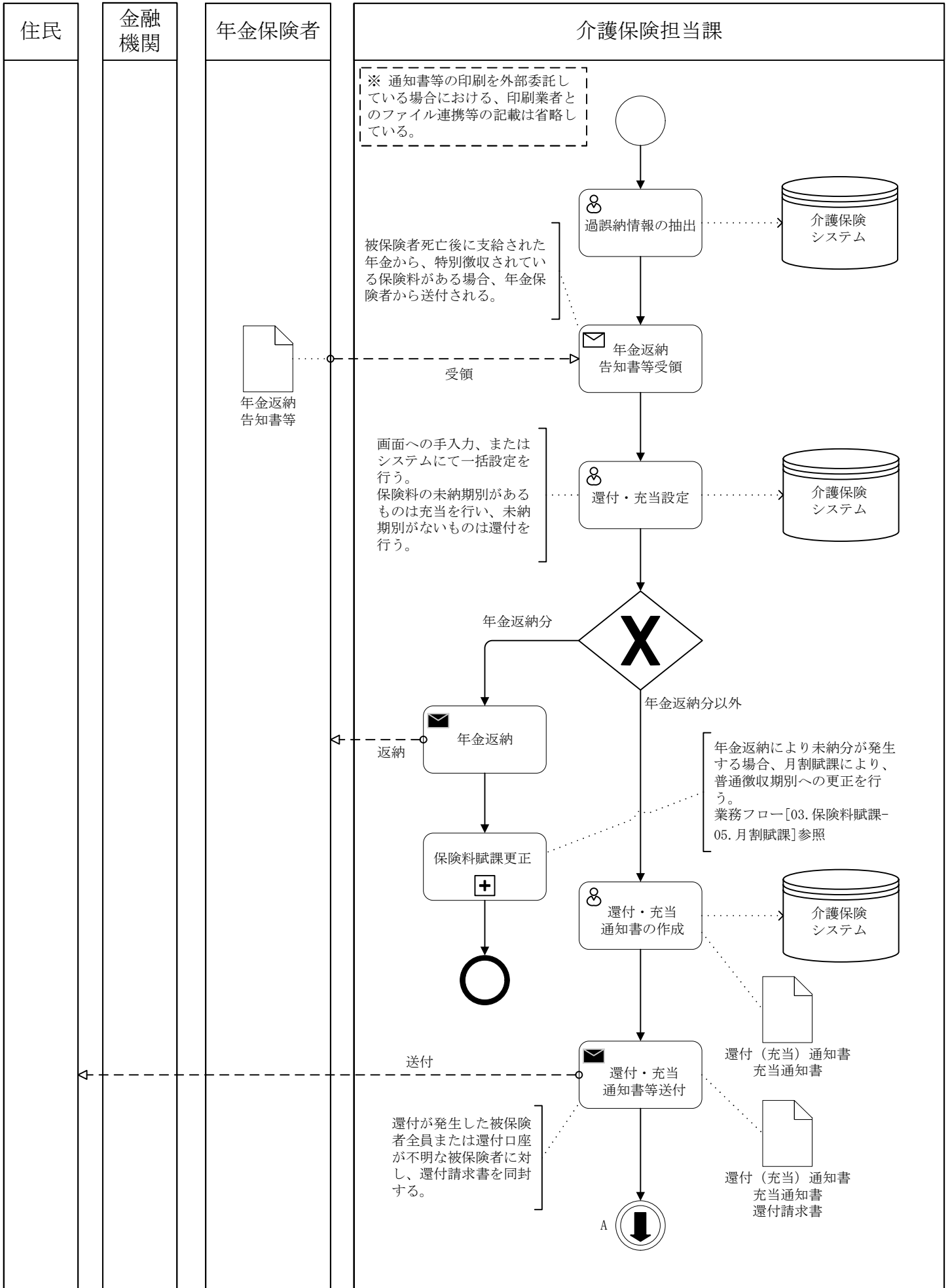

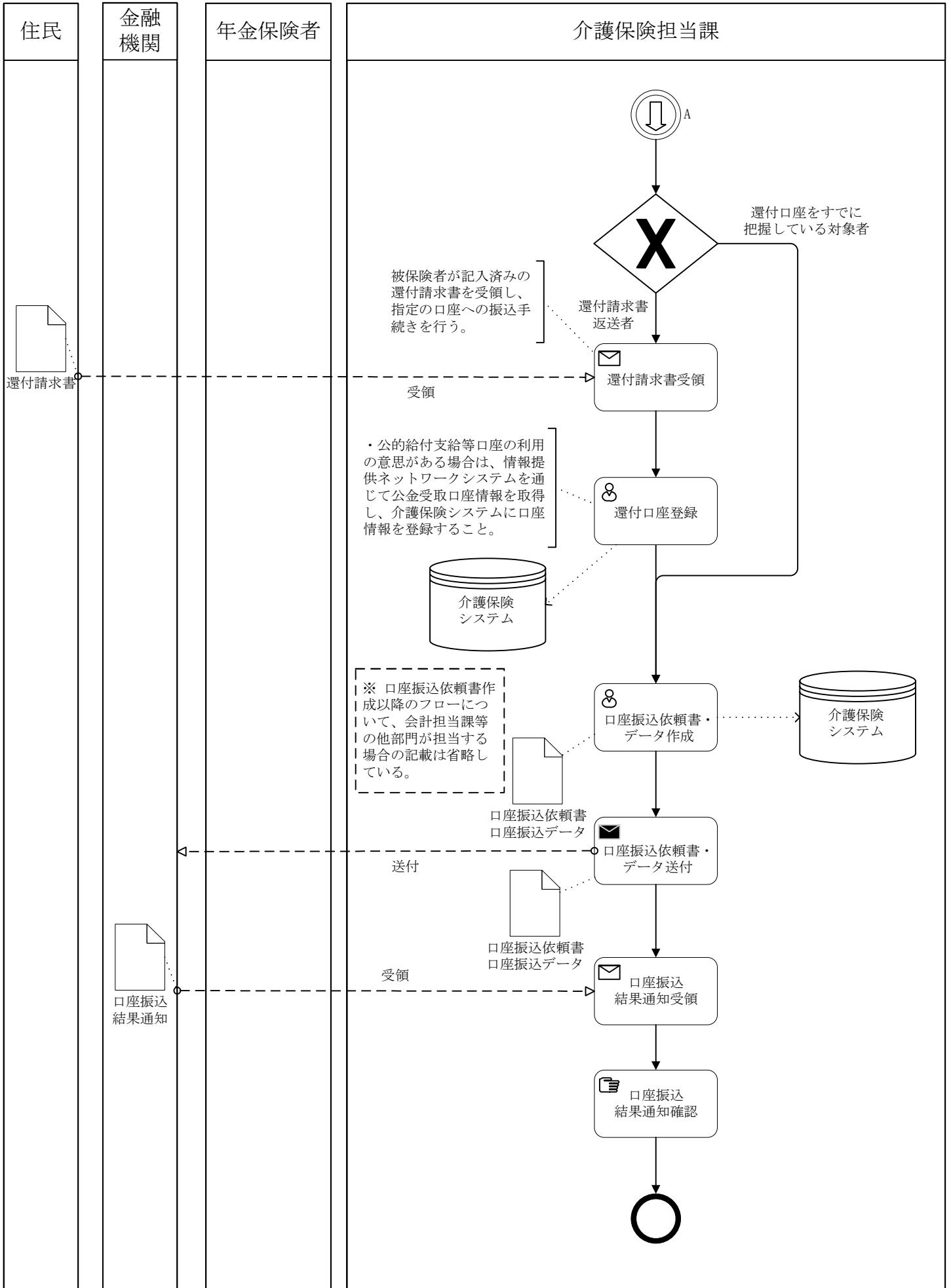

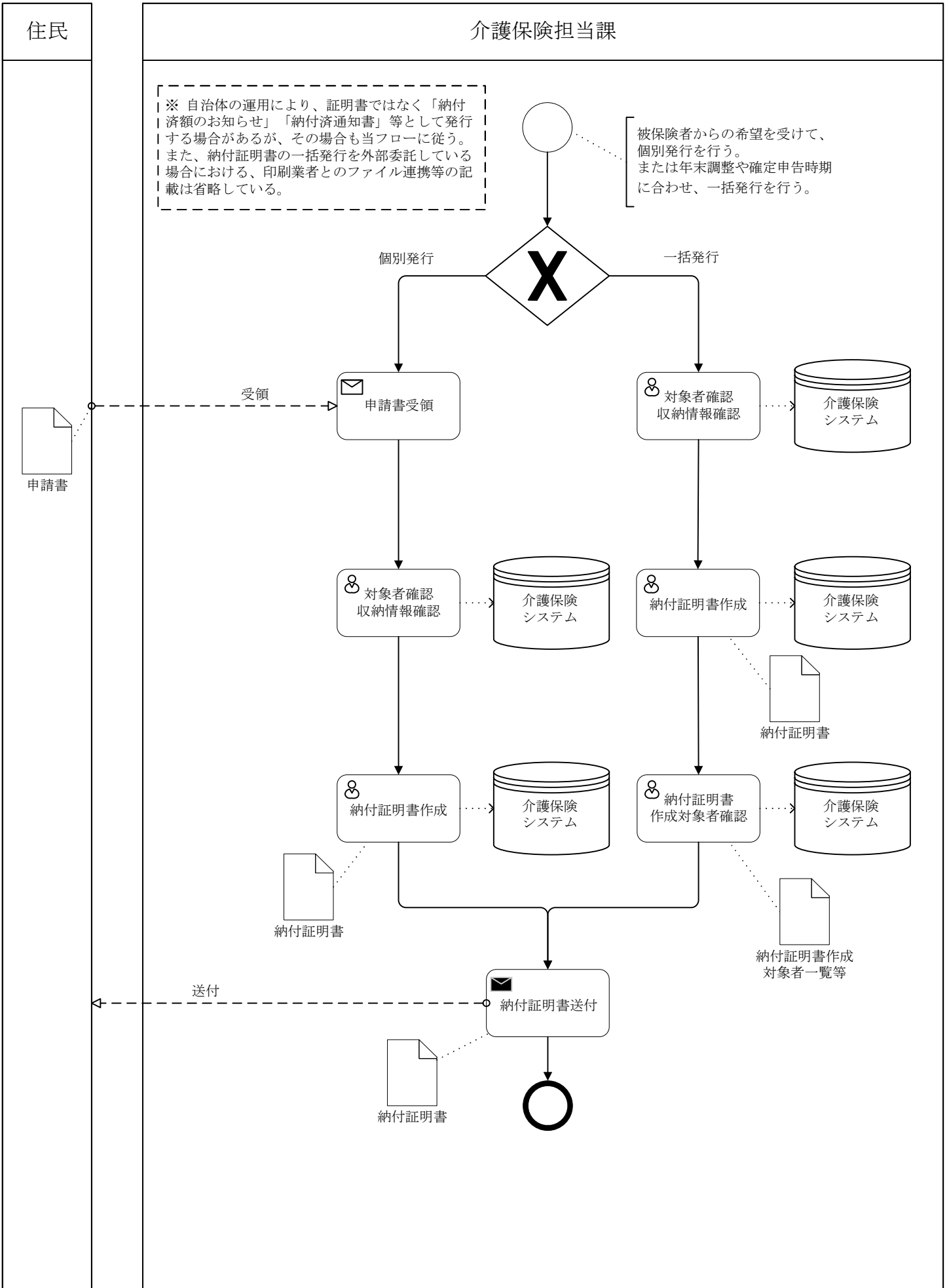

住民

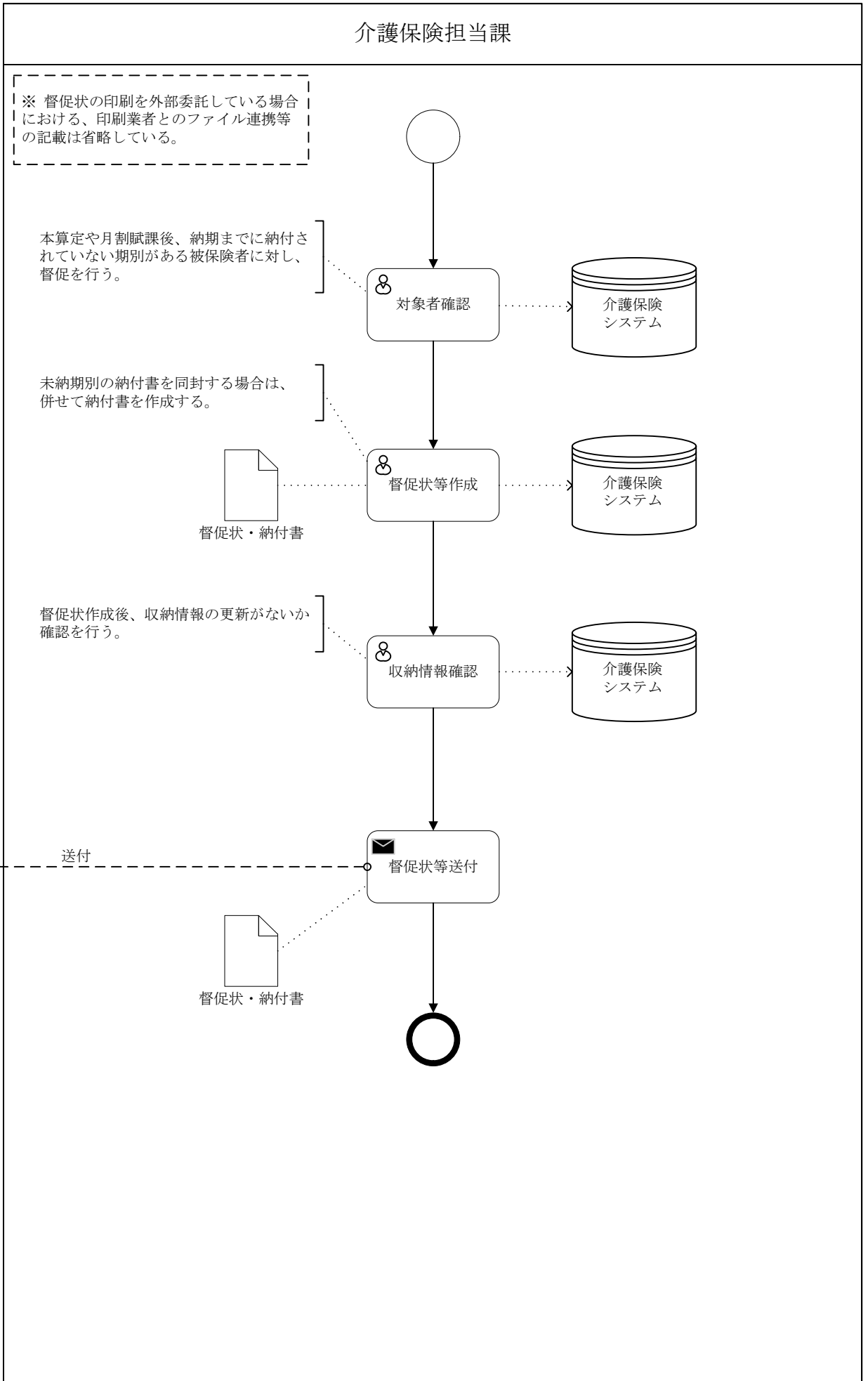

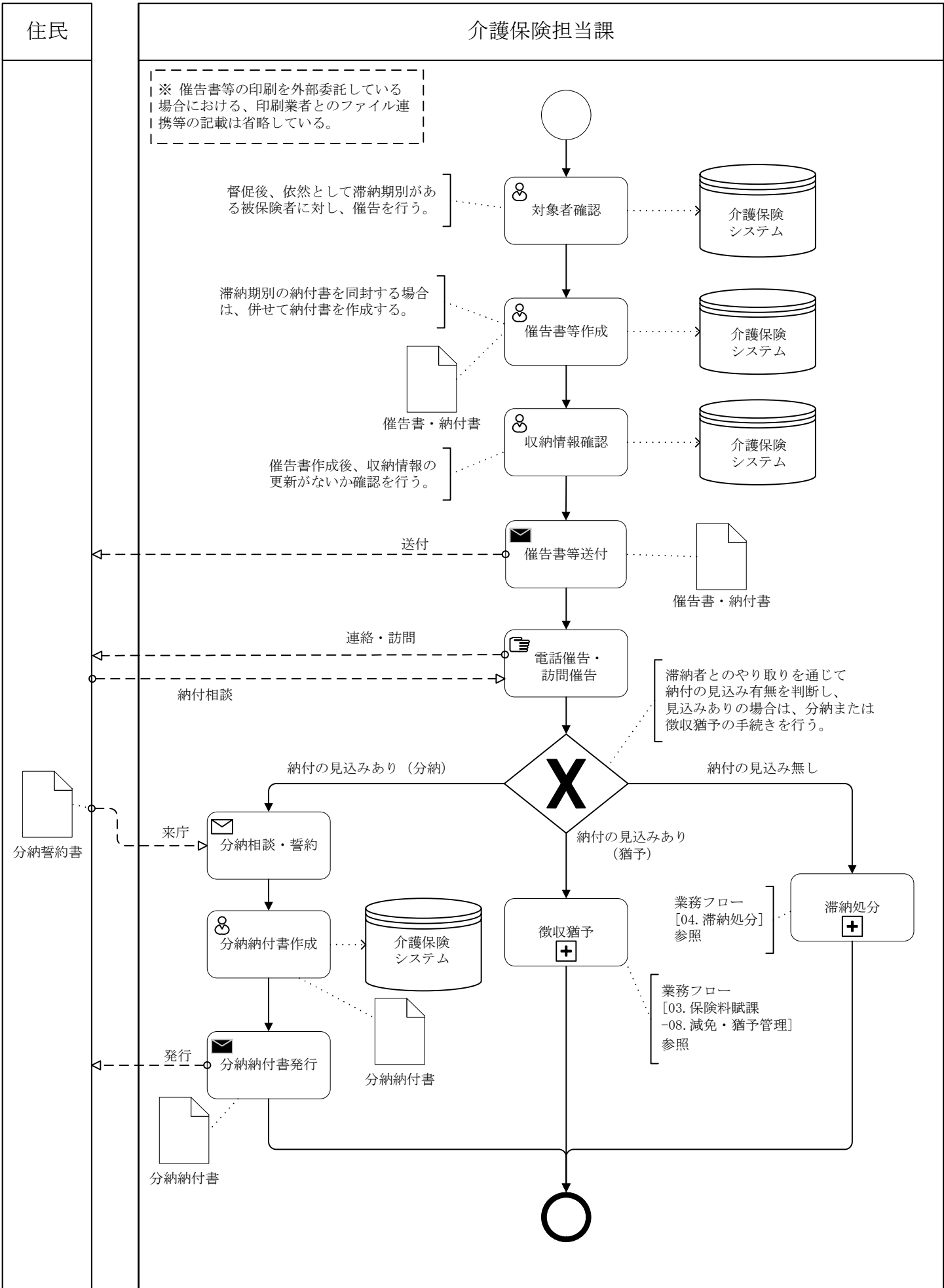

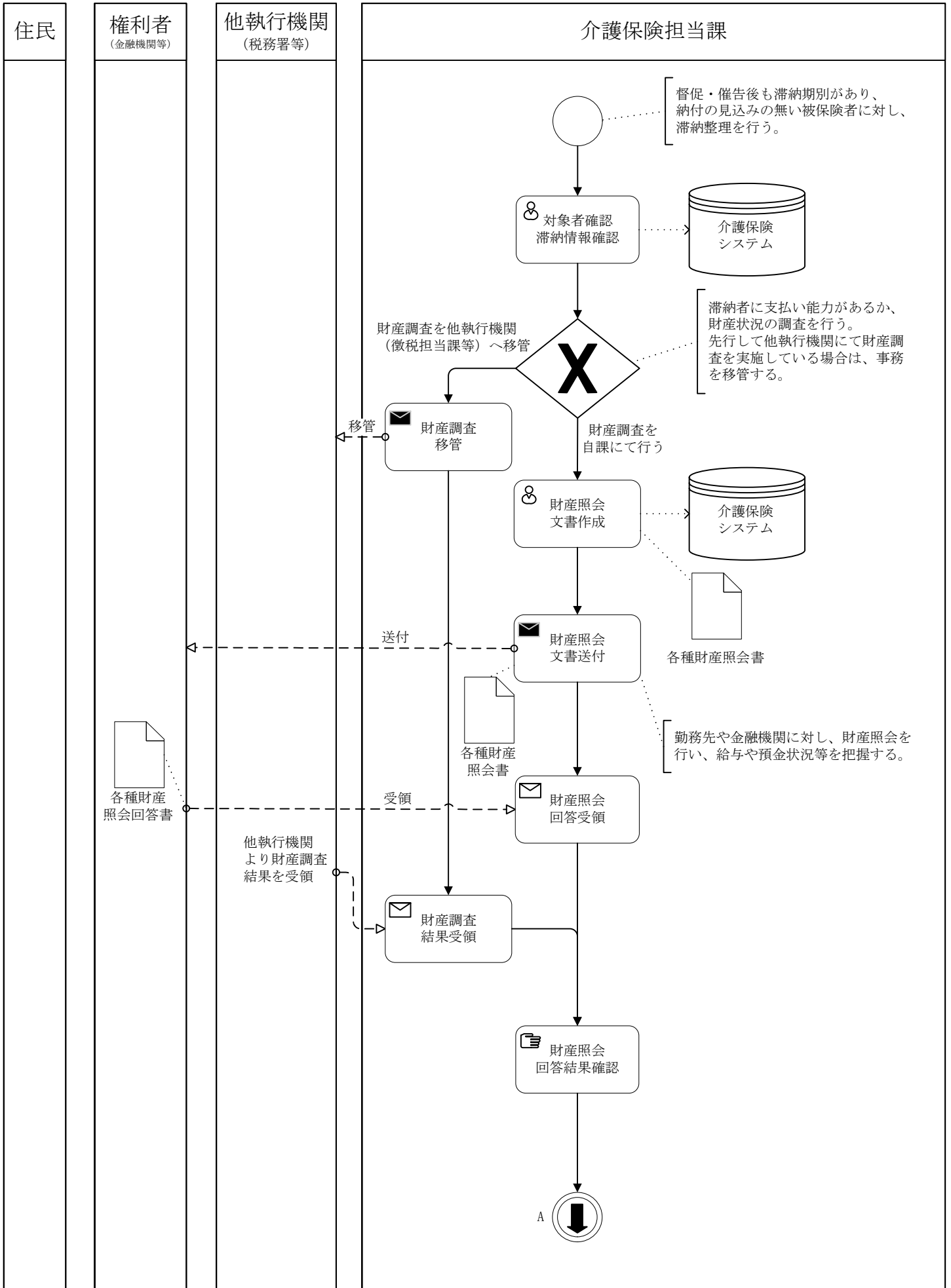

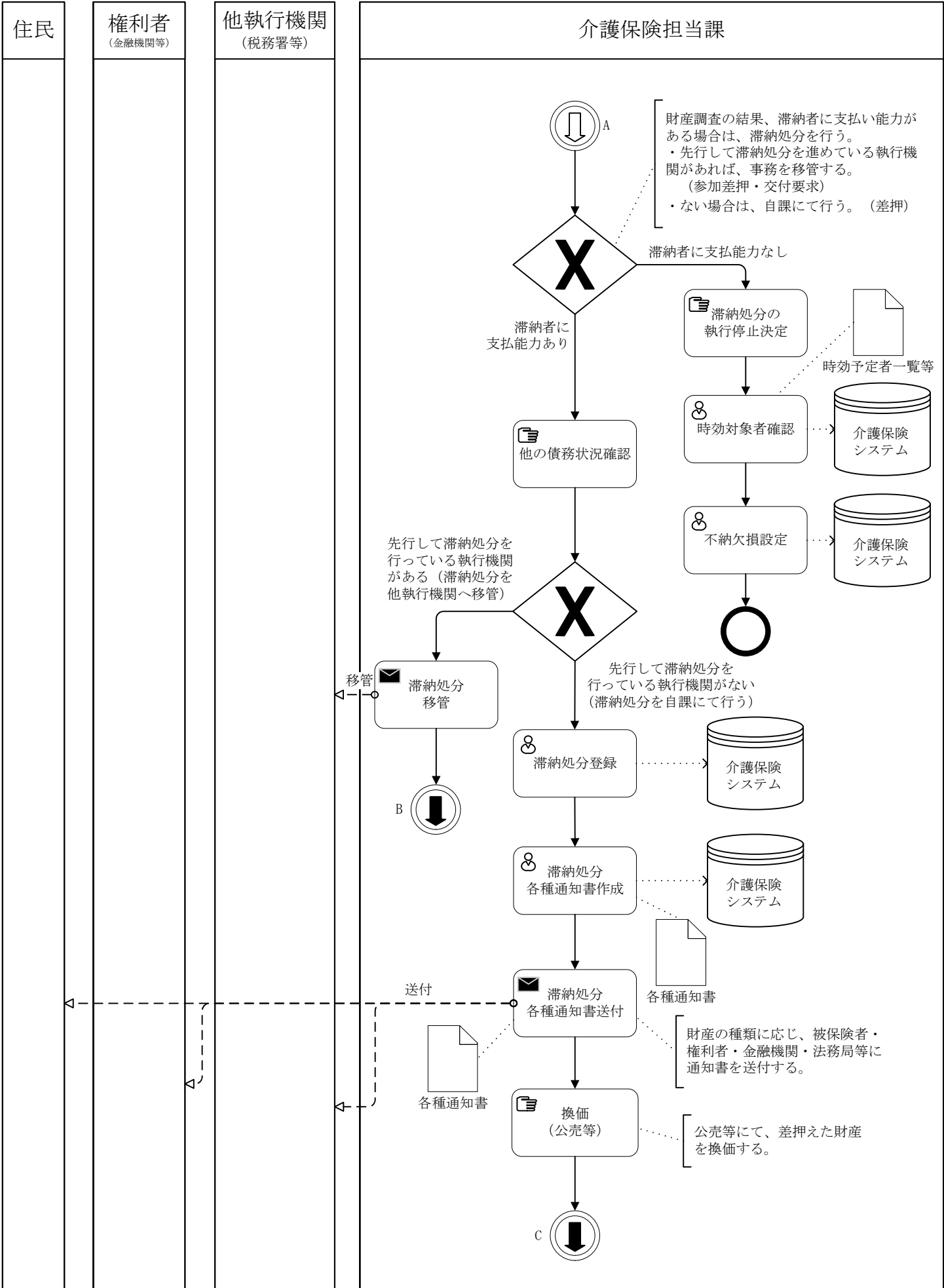

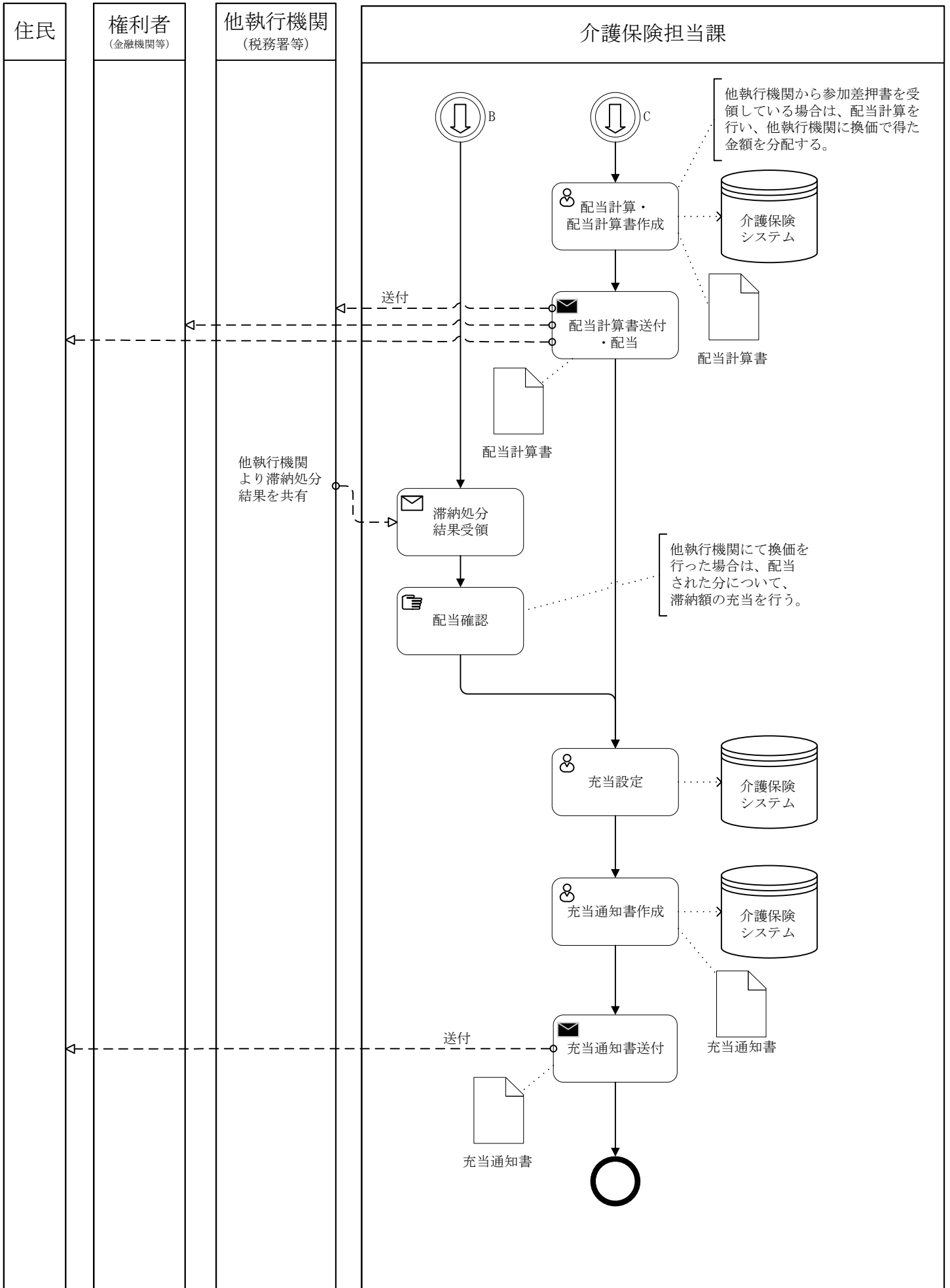

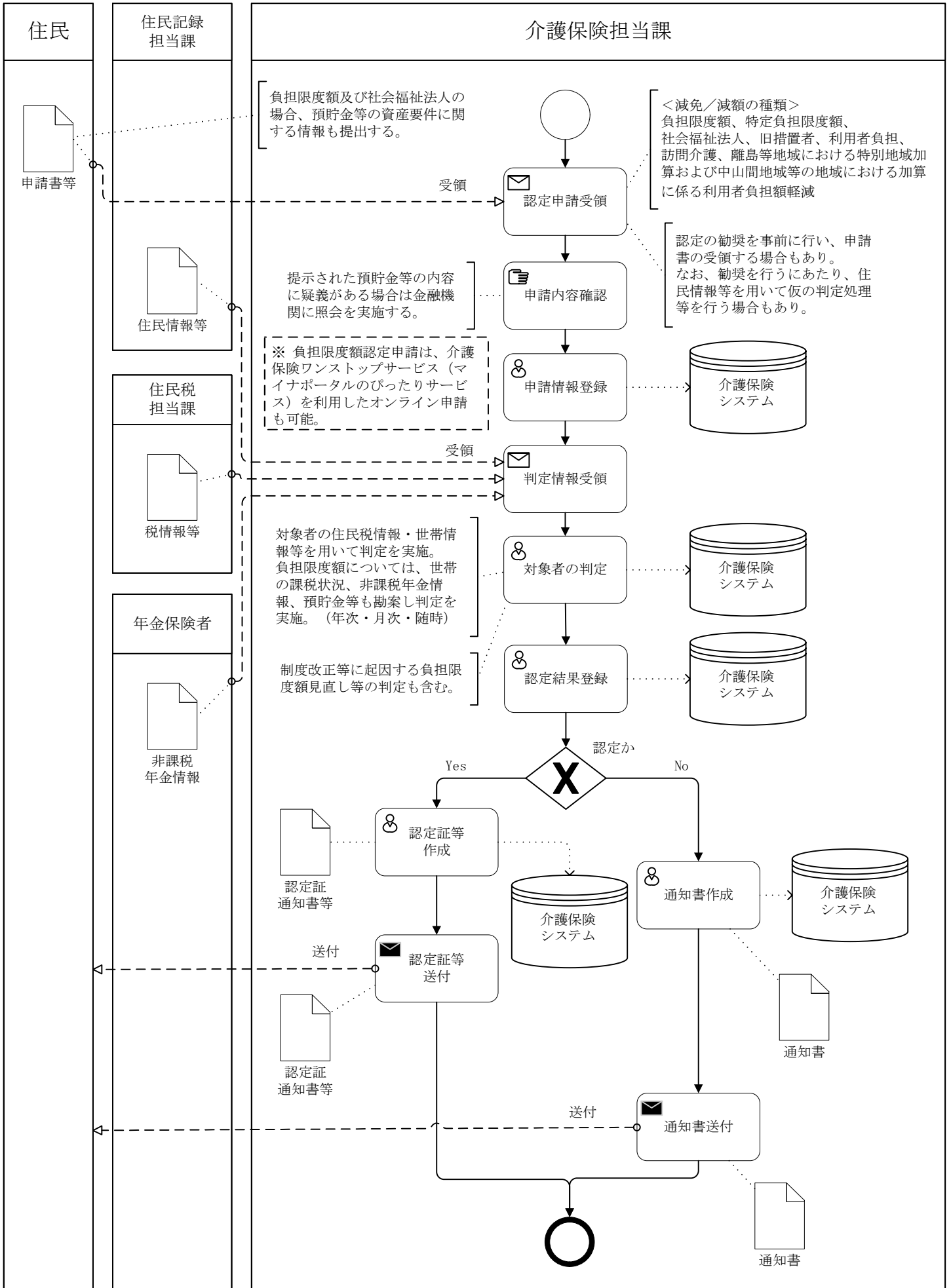

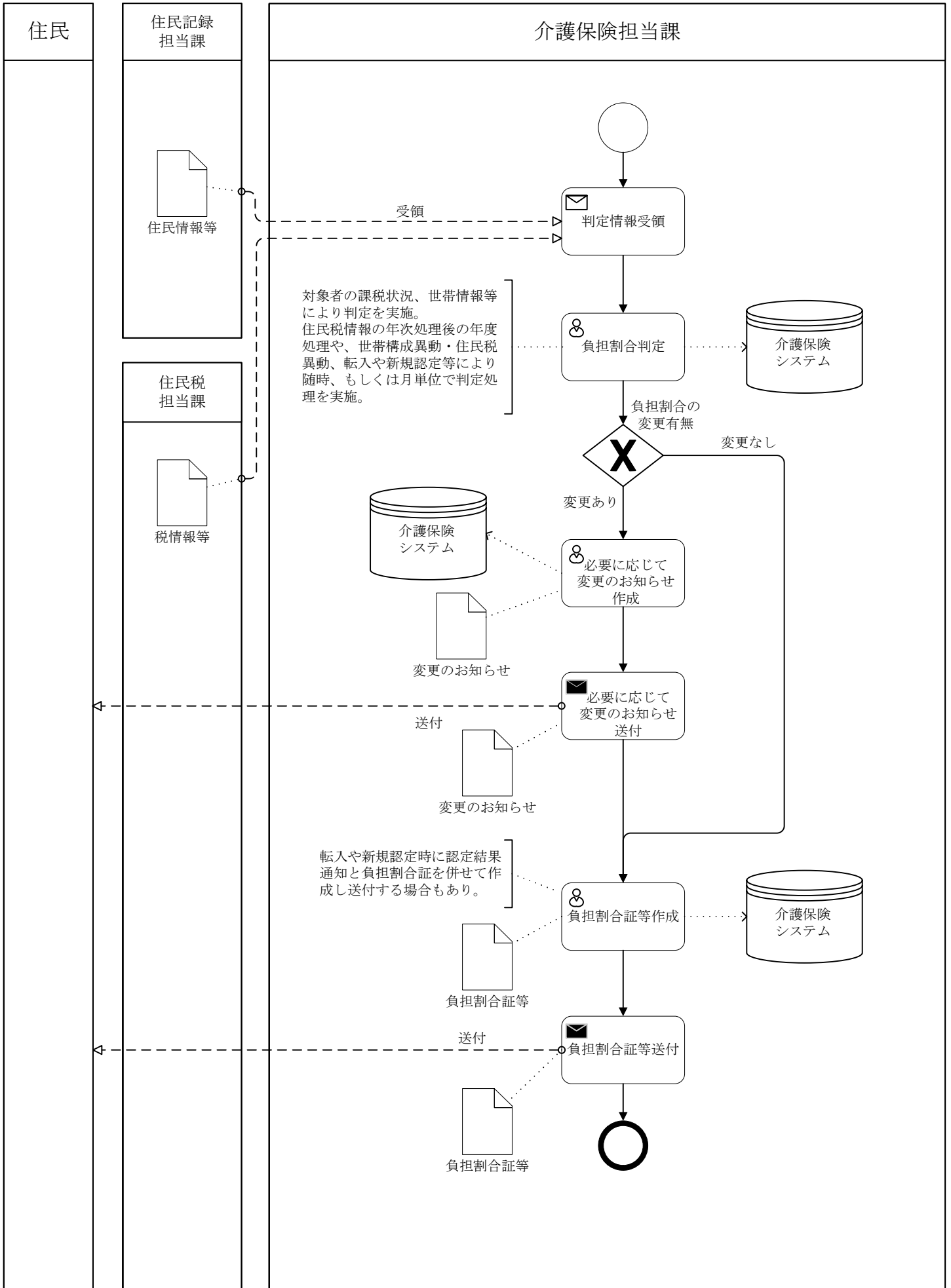

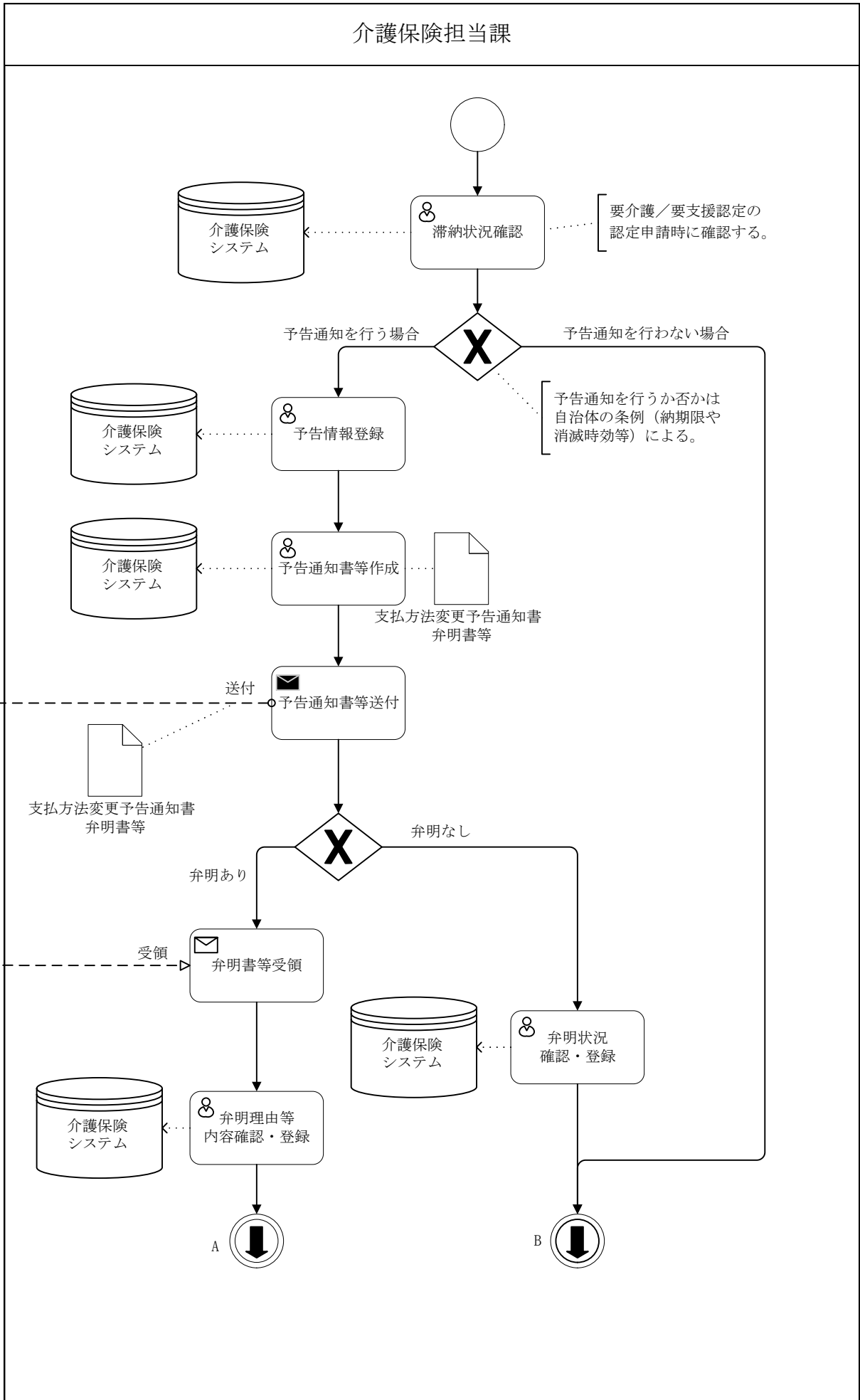
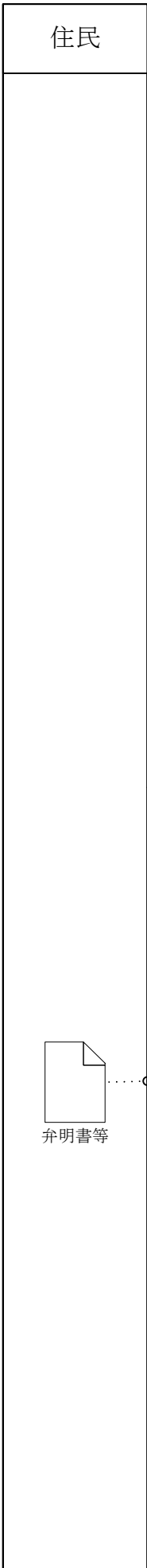

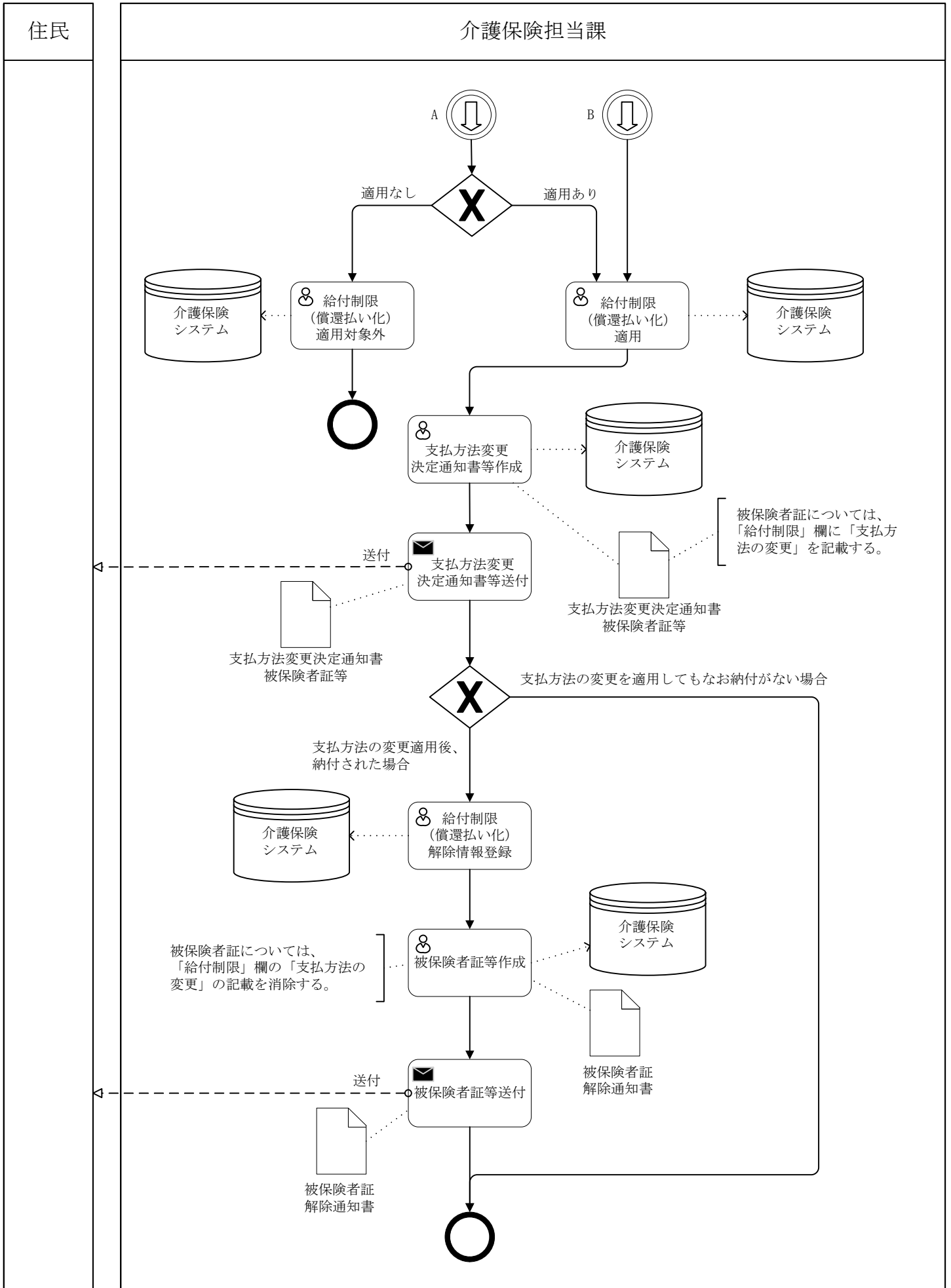

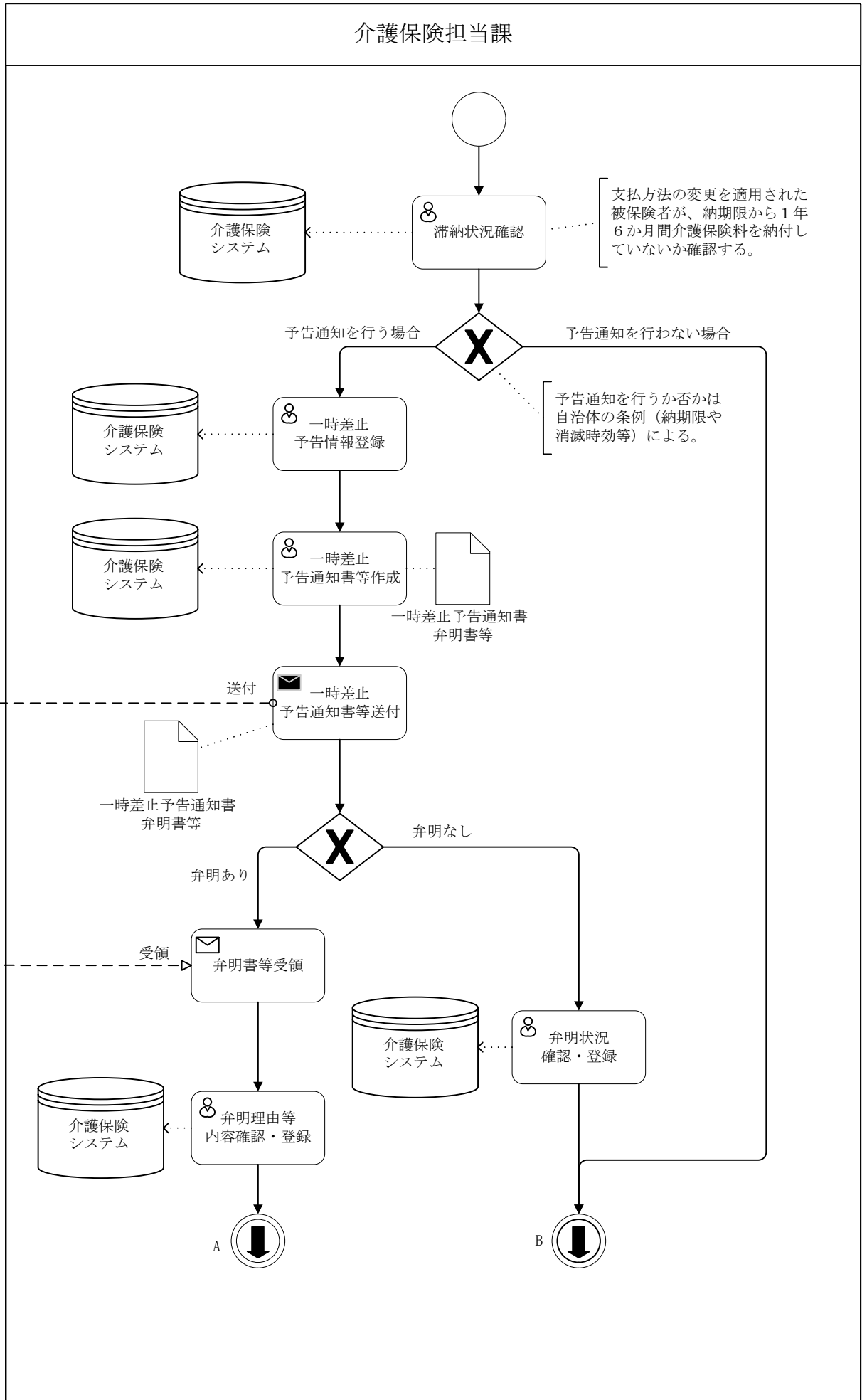
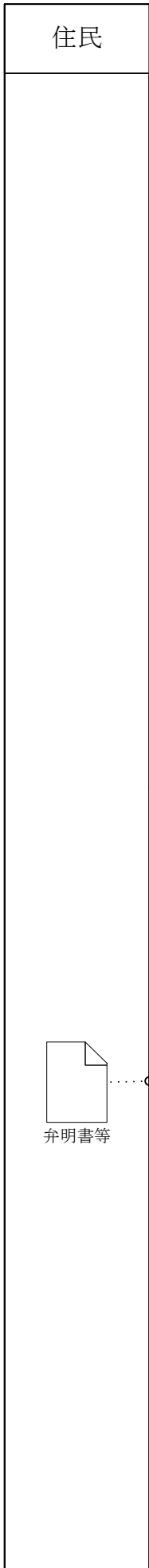

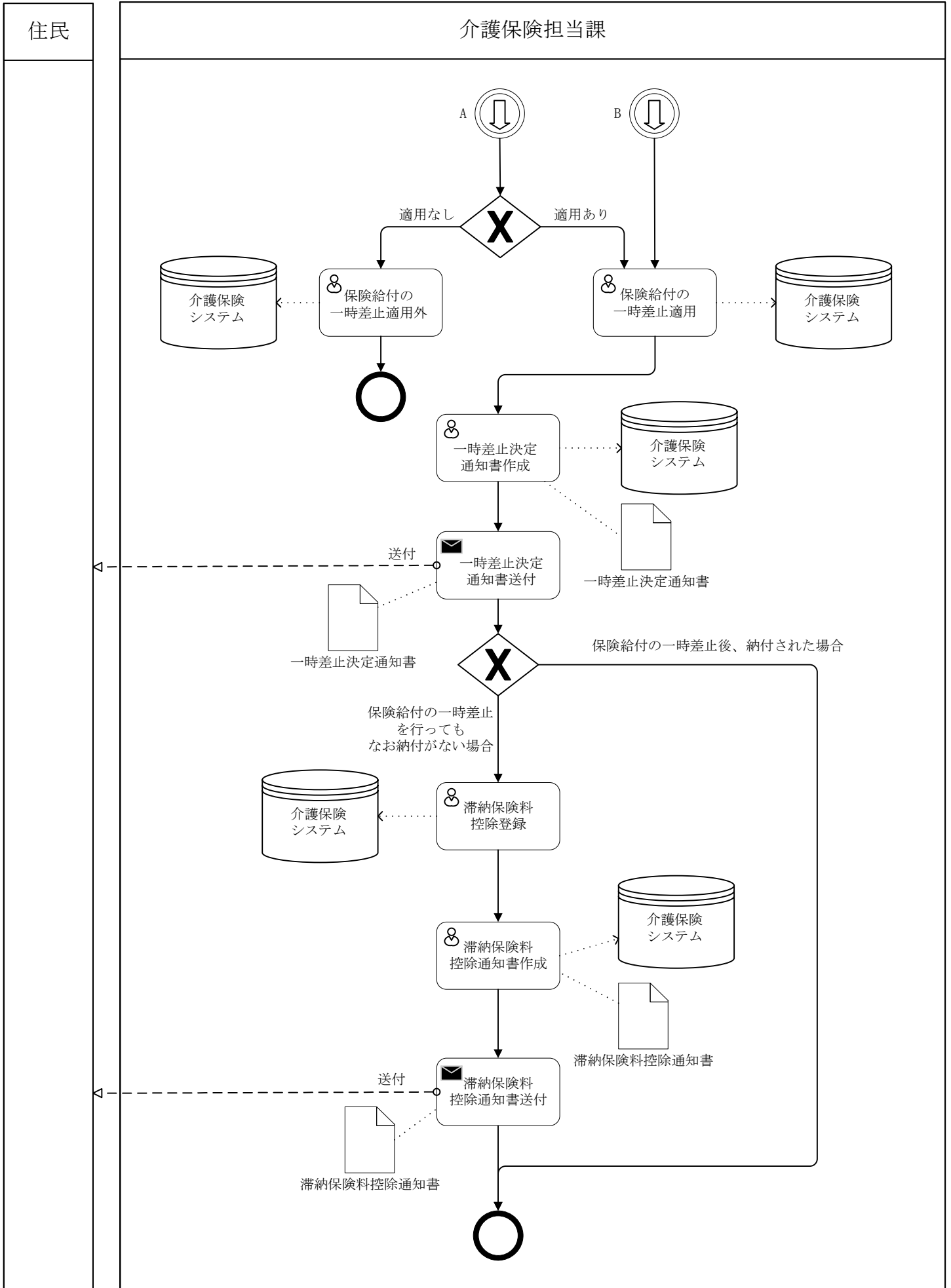

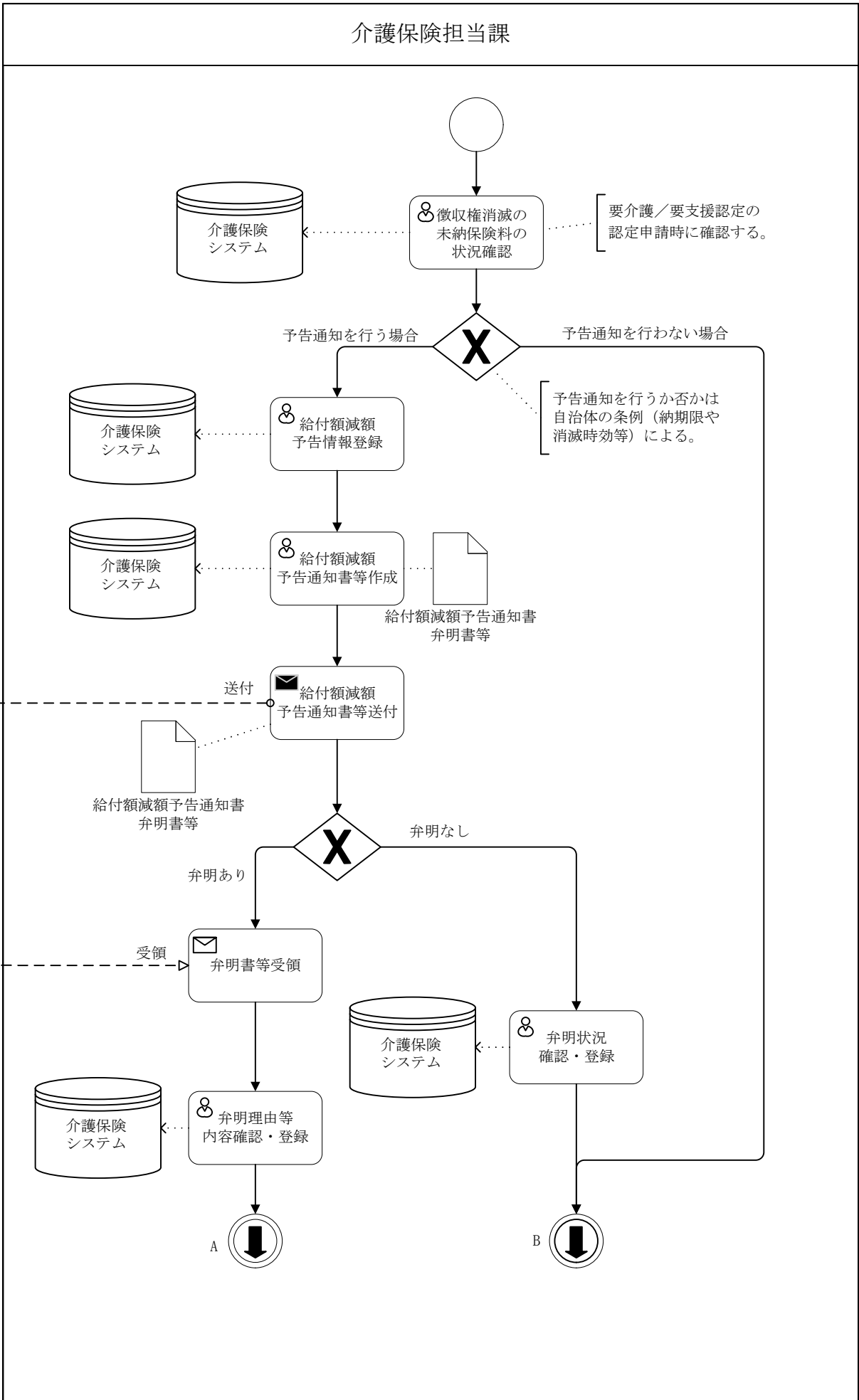
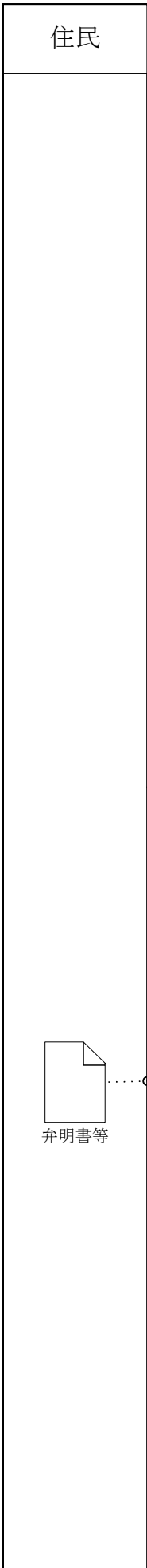

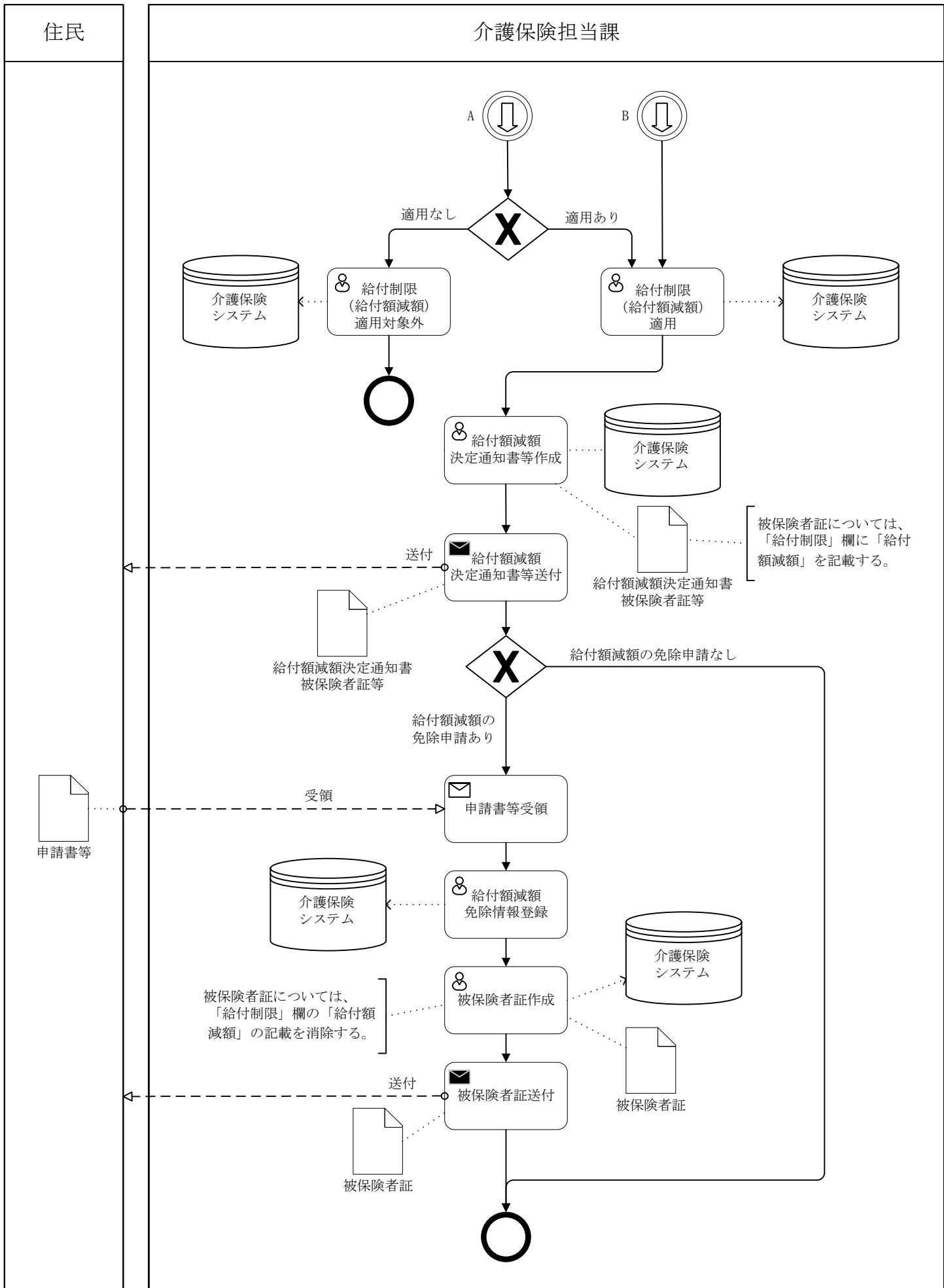

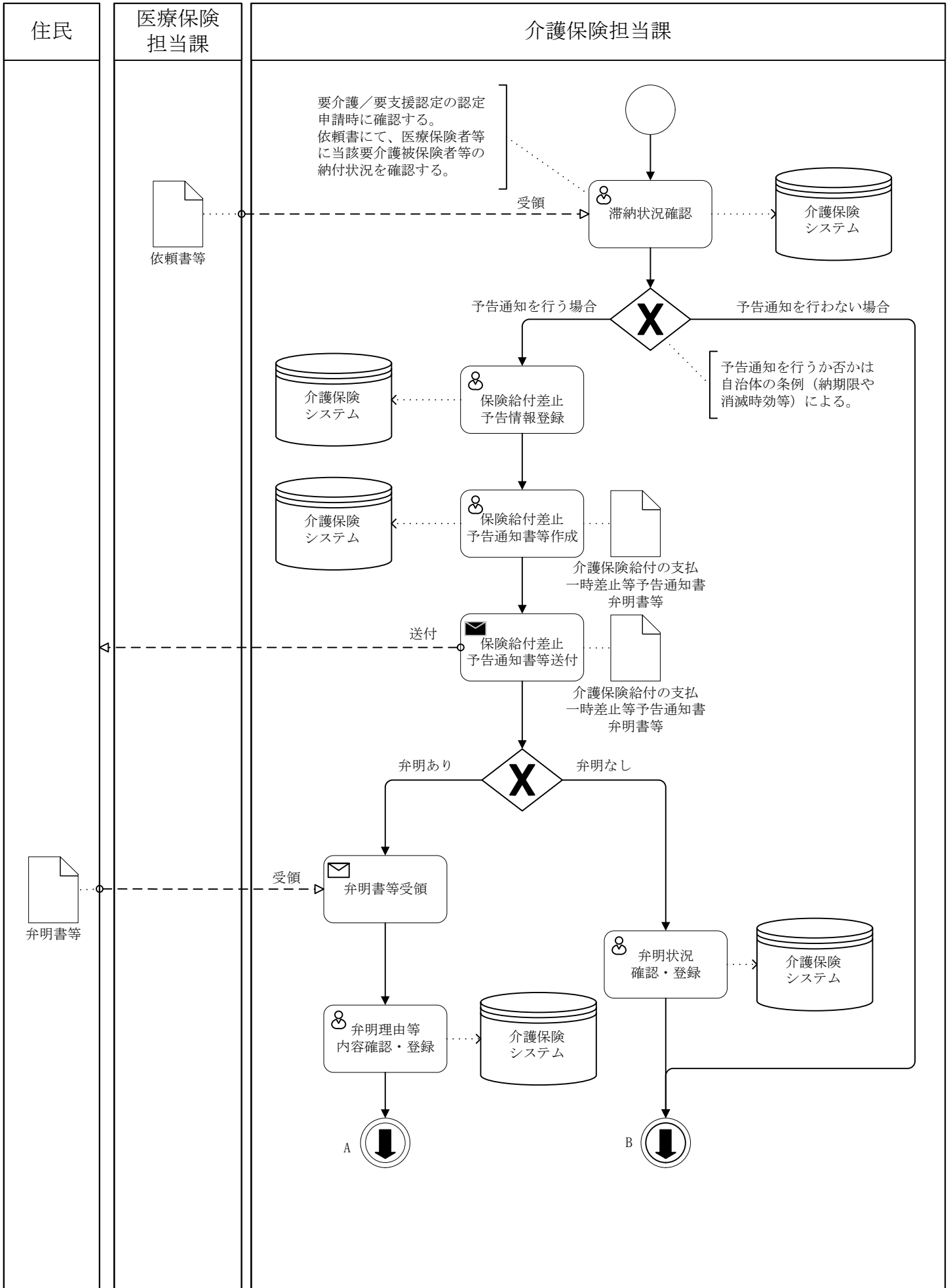

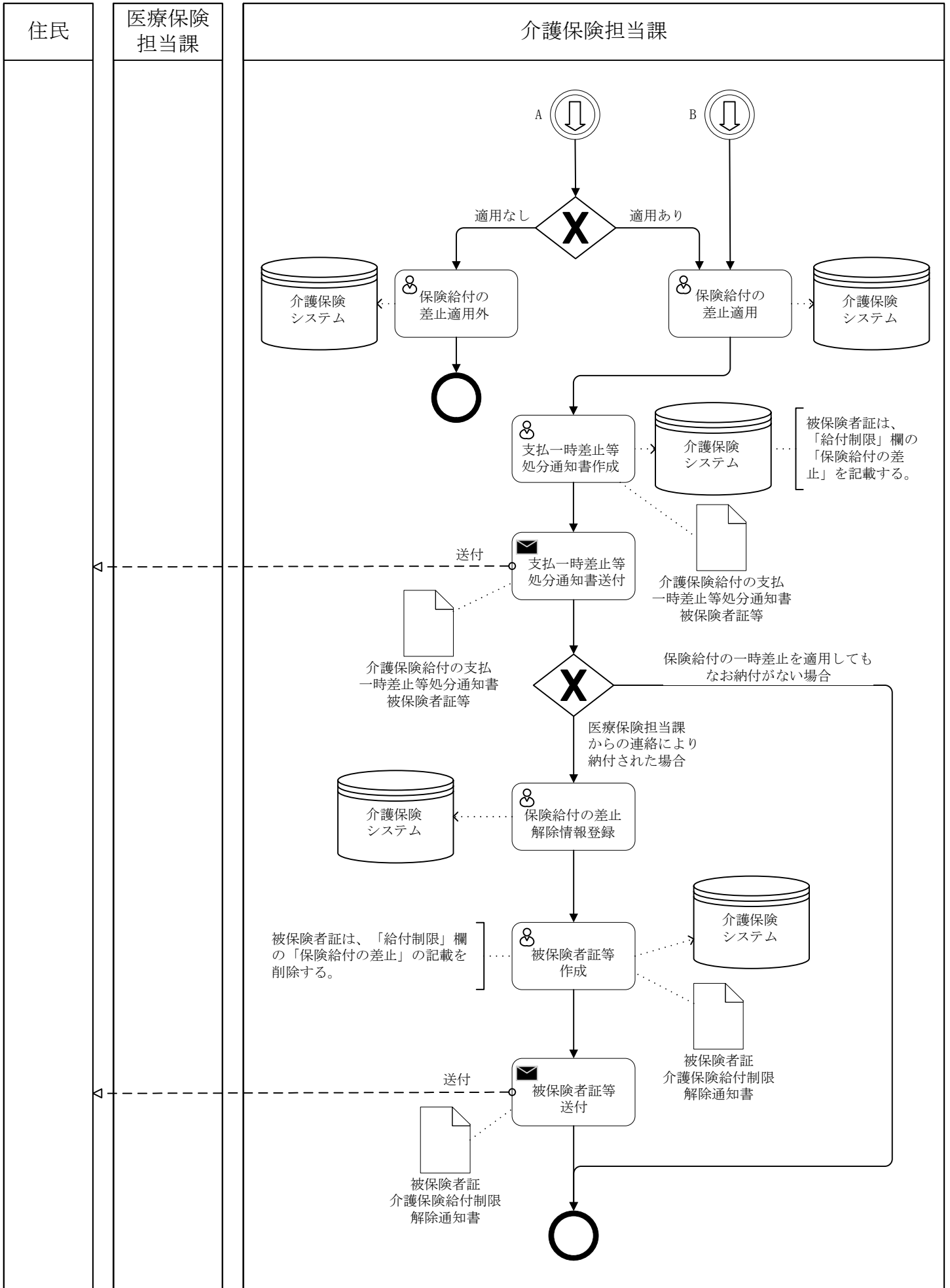

国保連合会

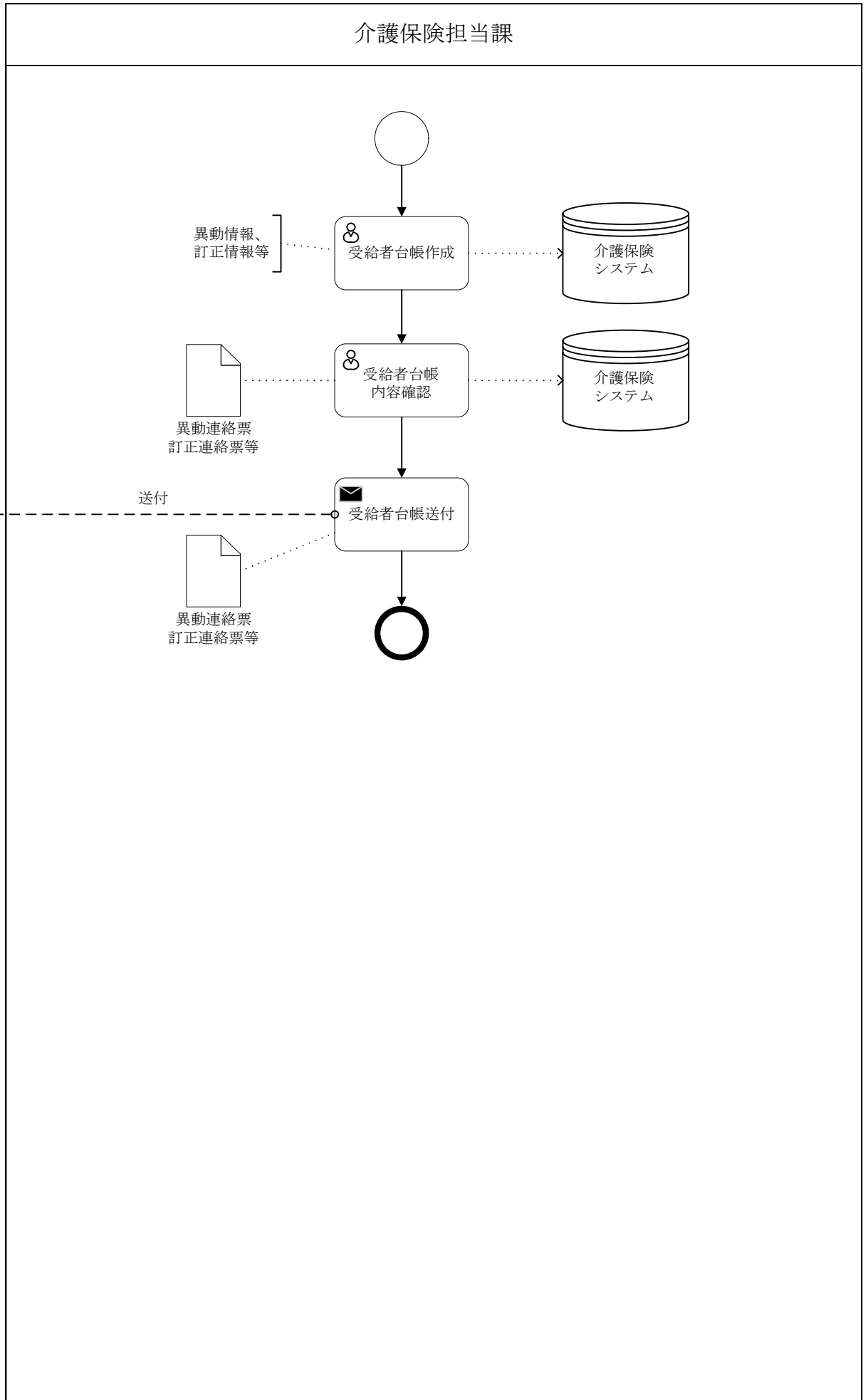

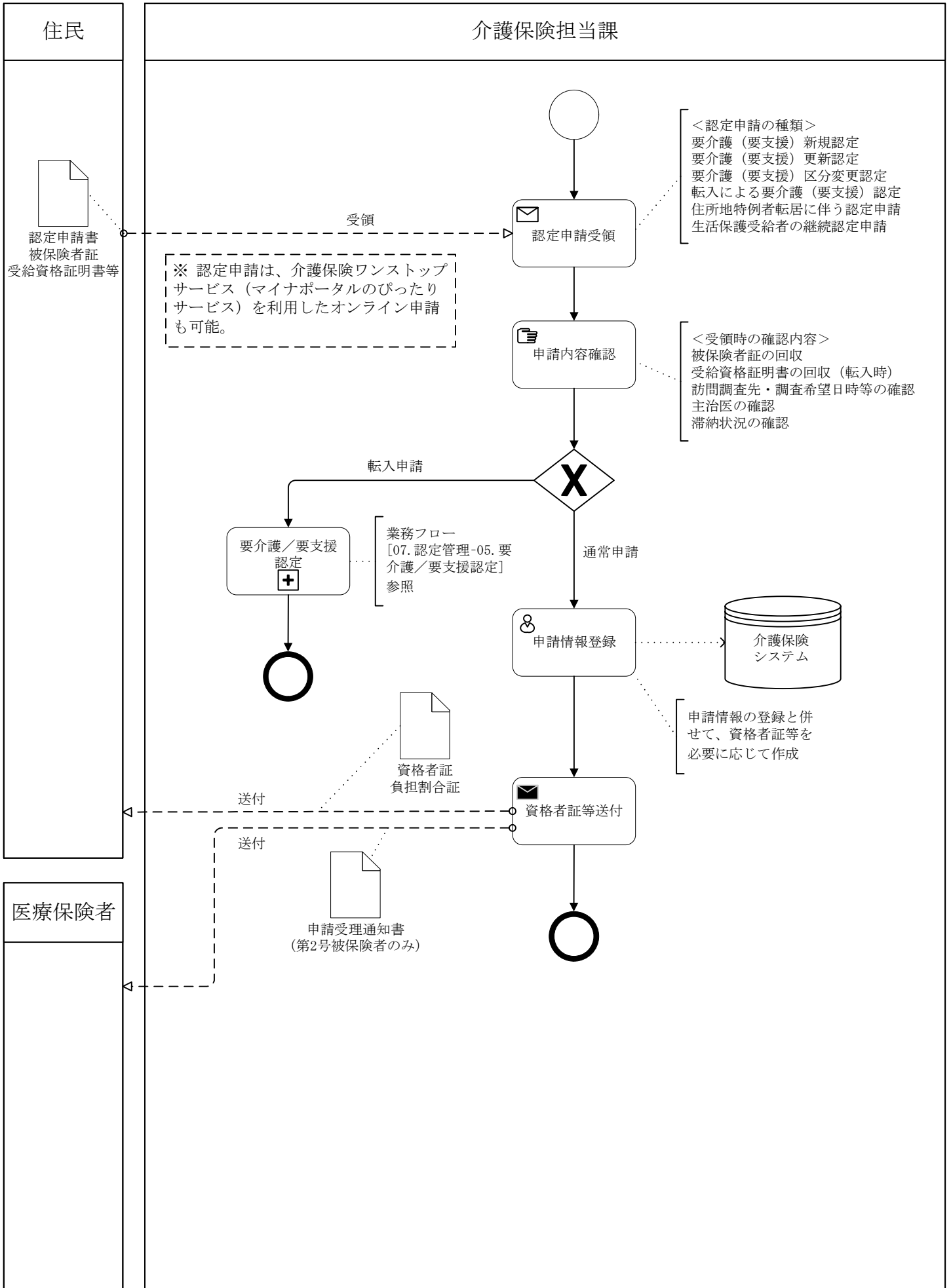

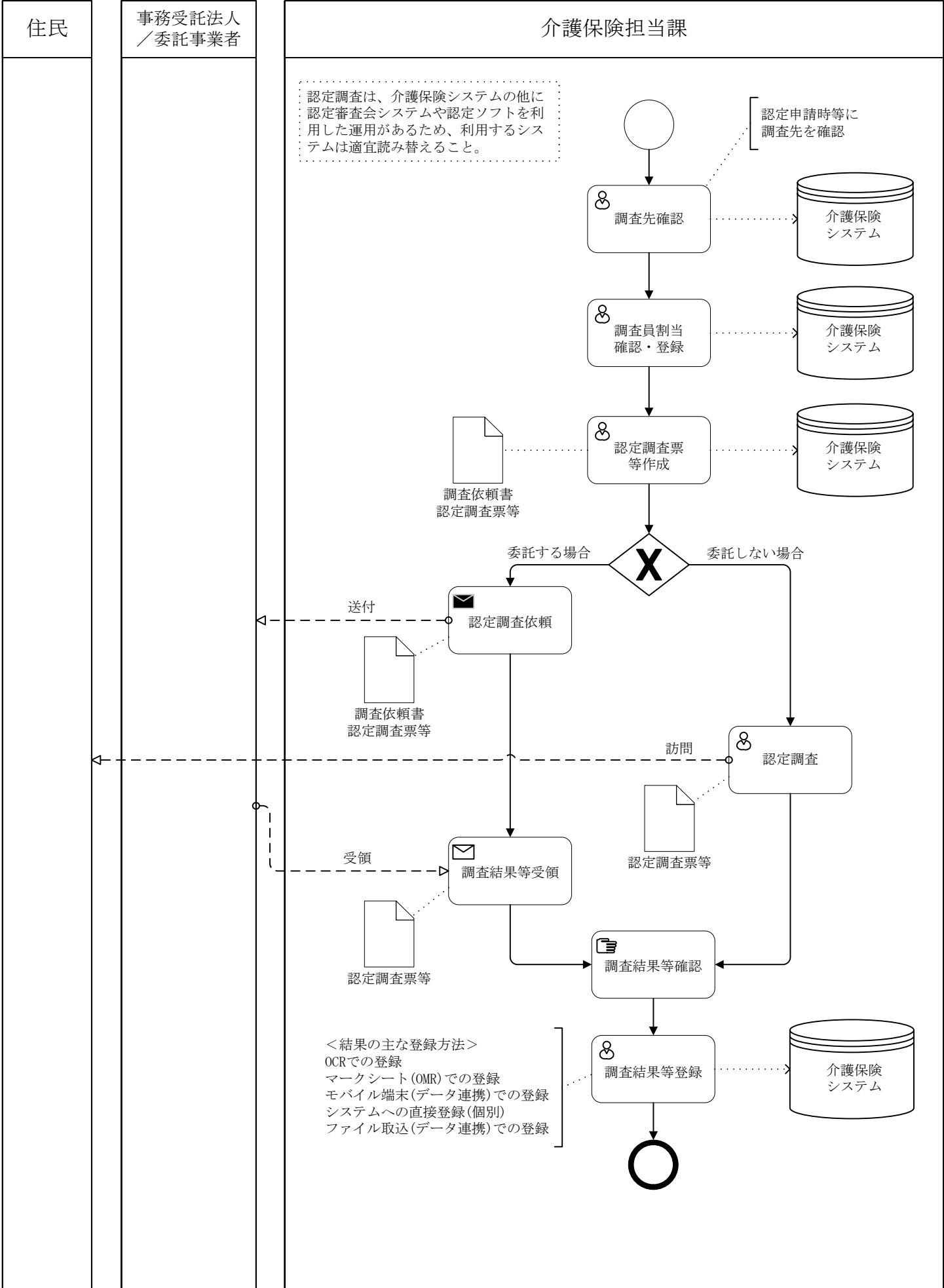

医療機関

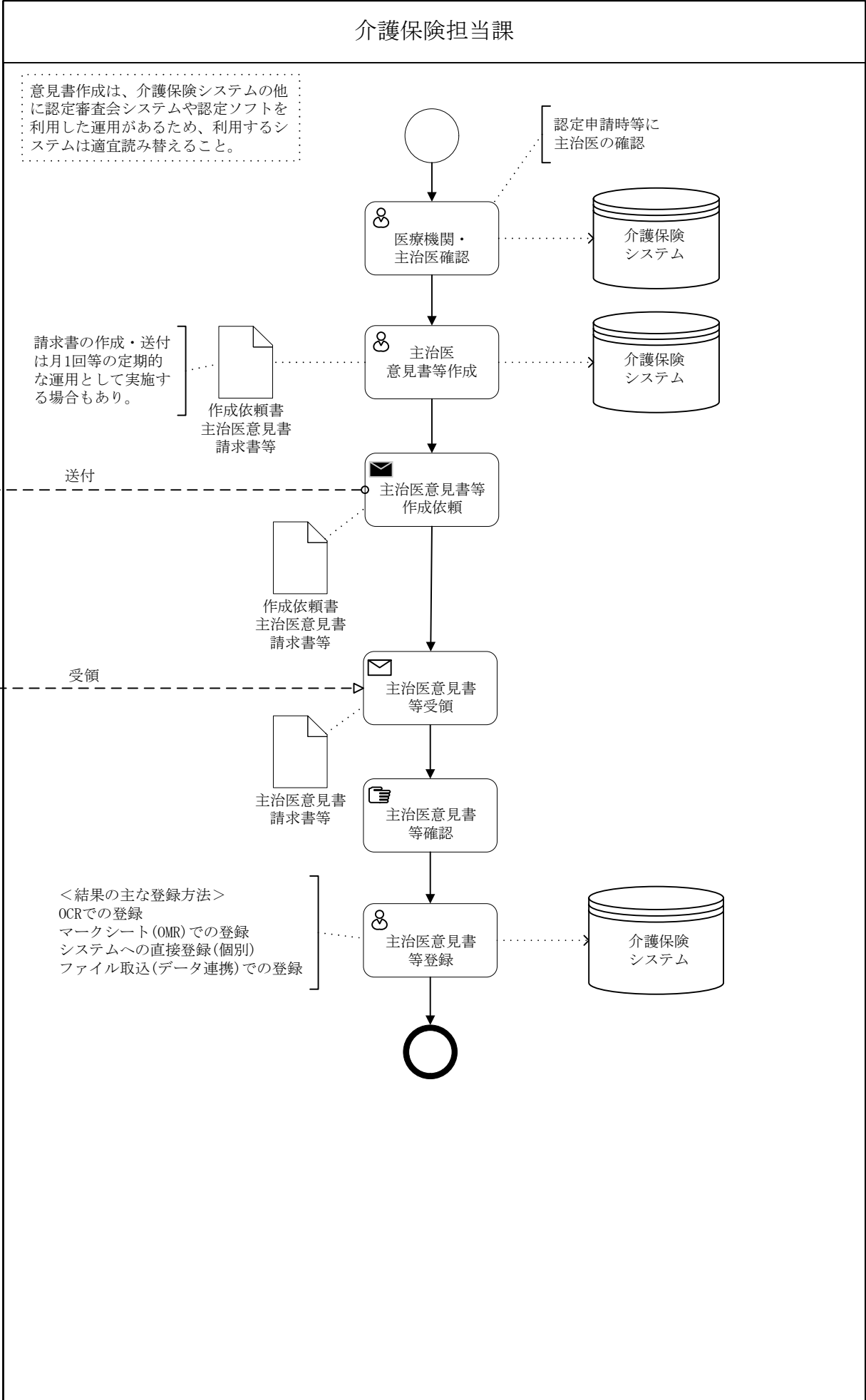

審査員

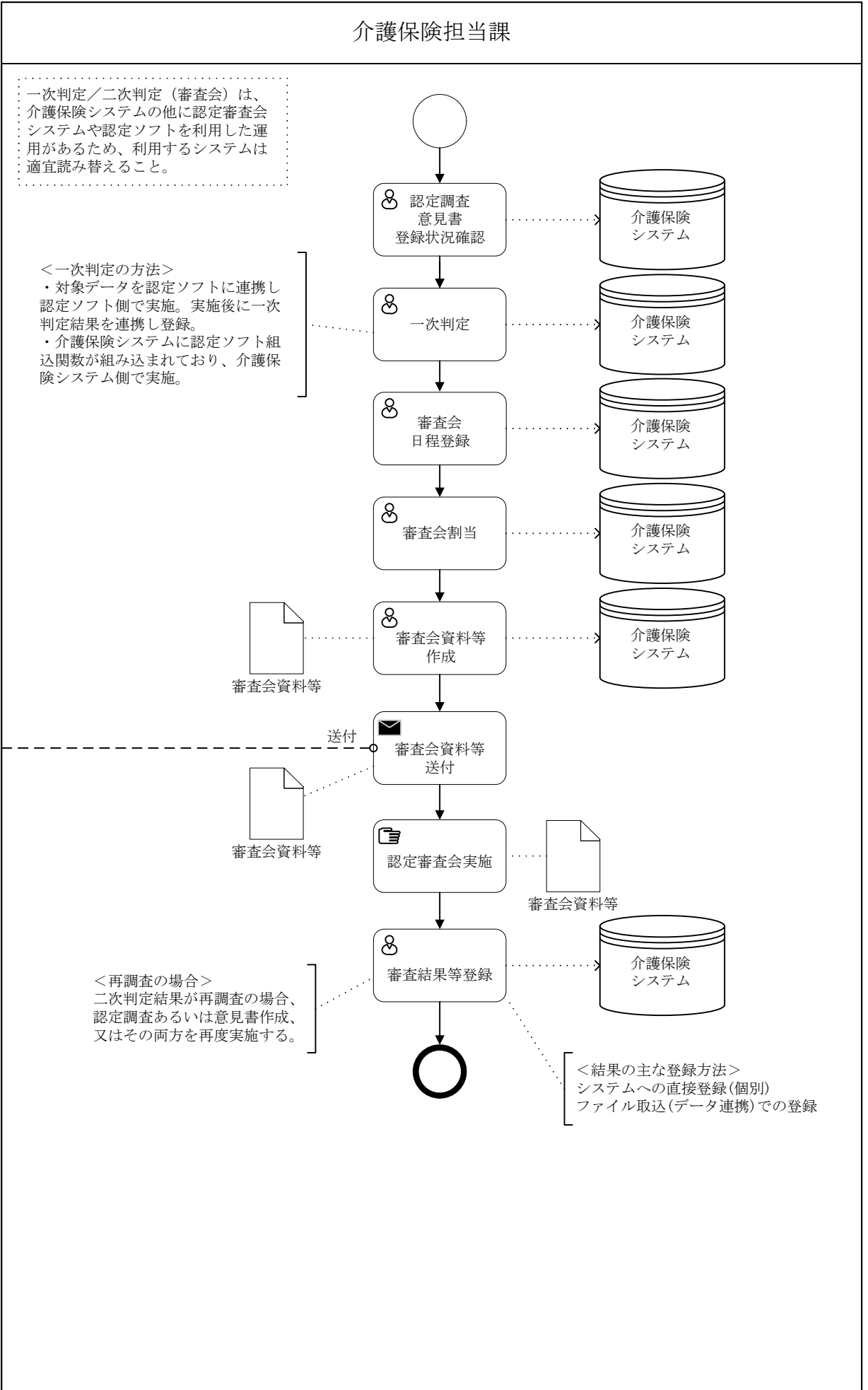

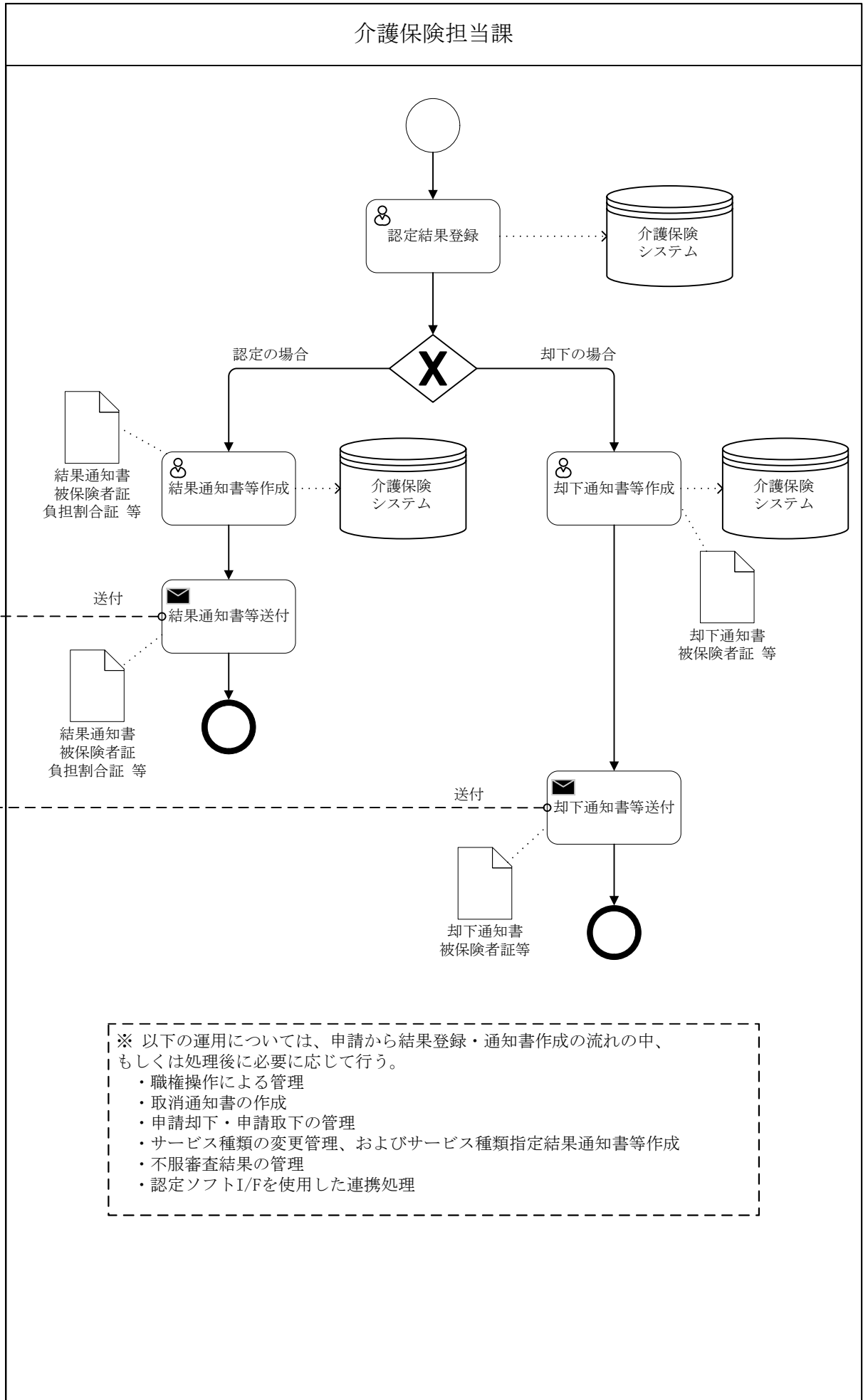

住民

介護保険担当課

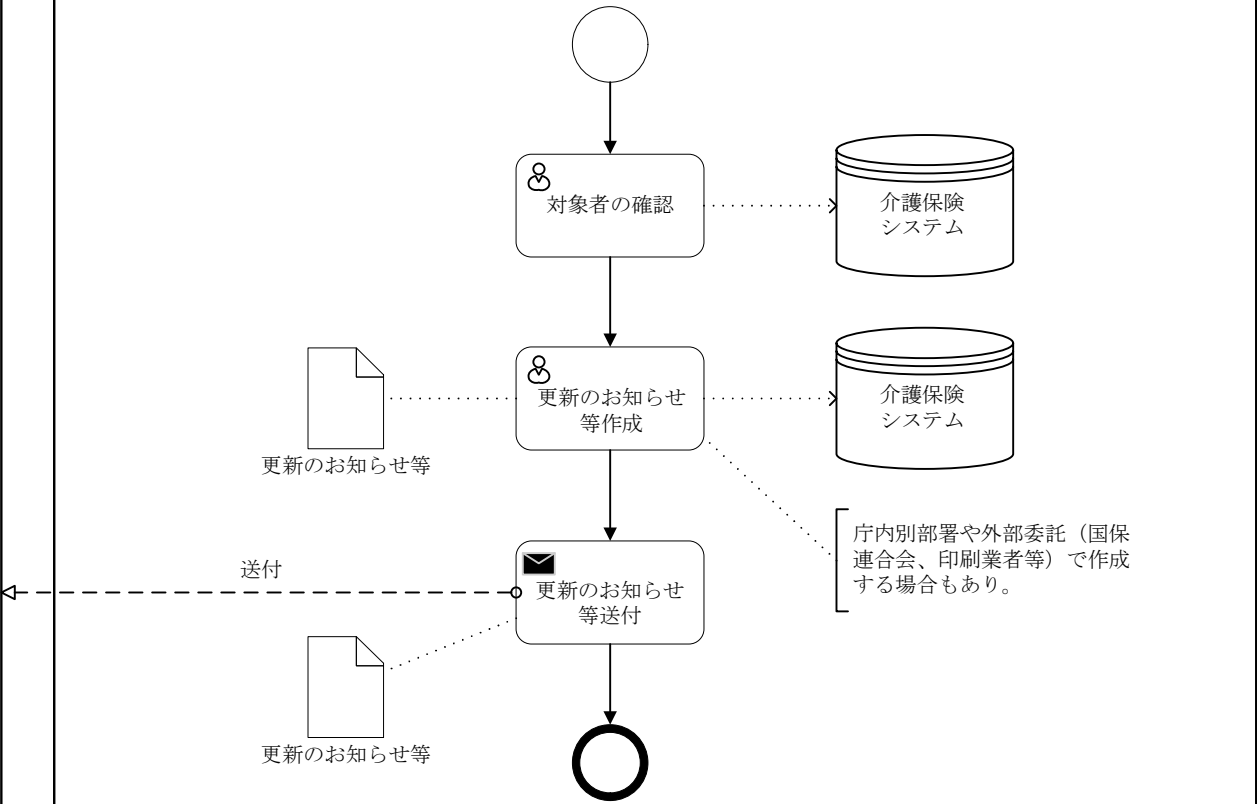

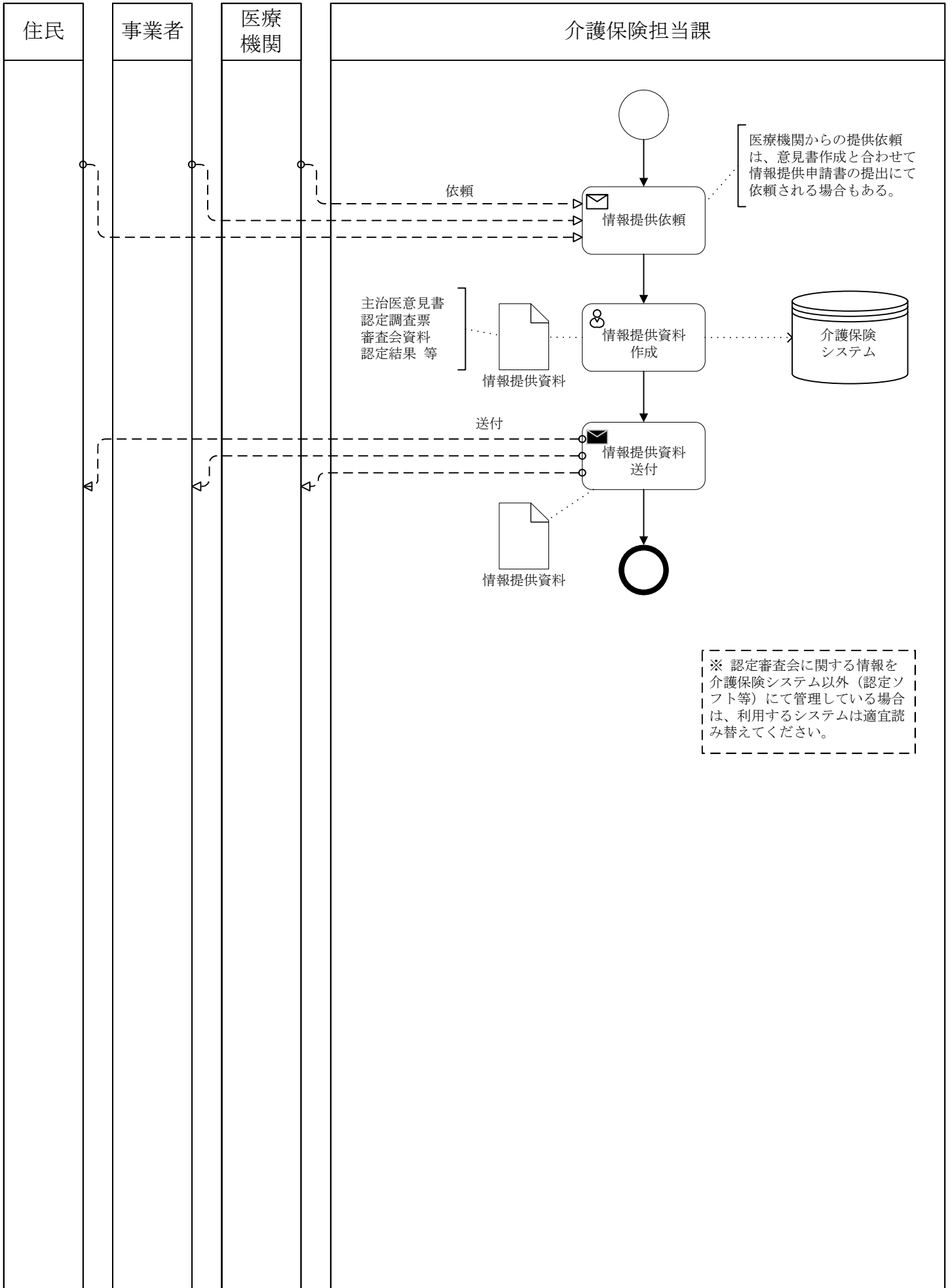

住民

介護保険担当課

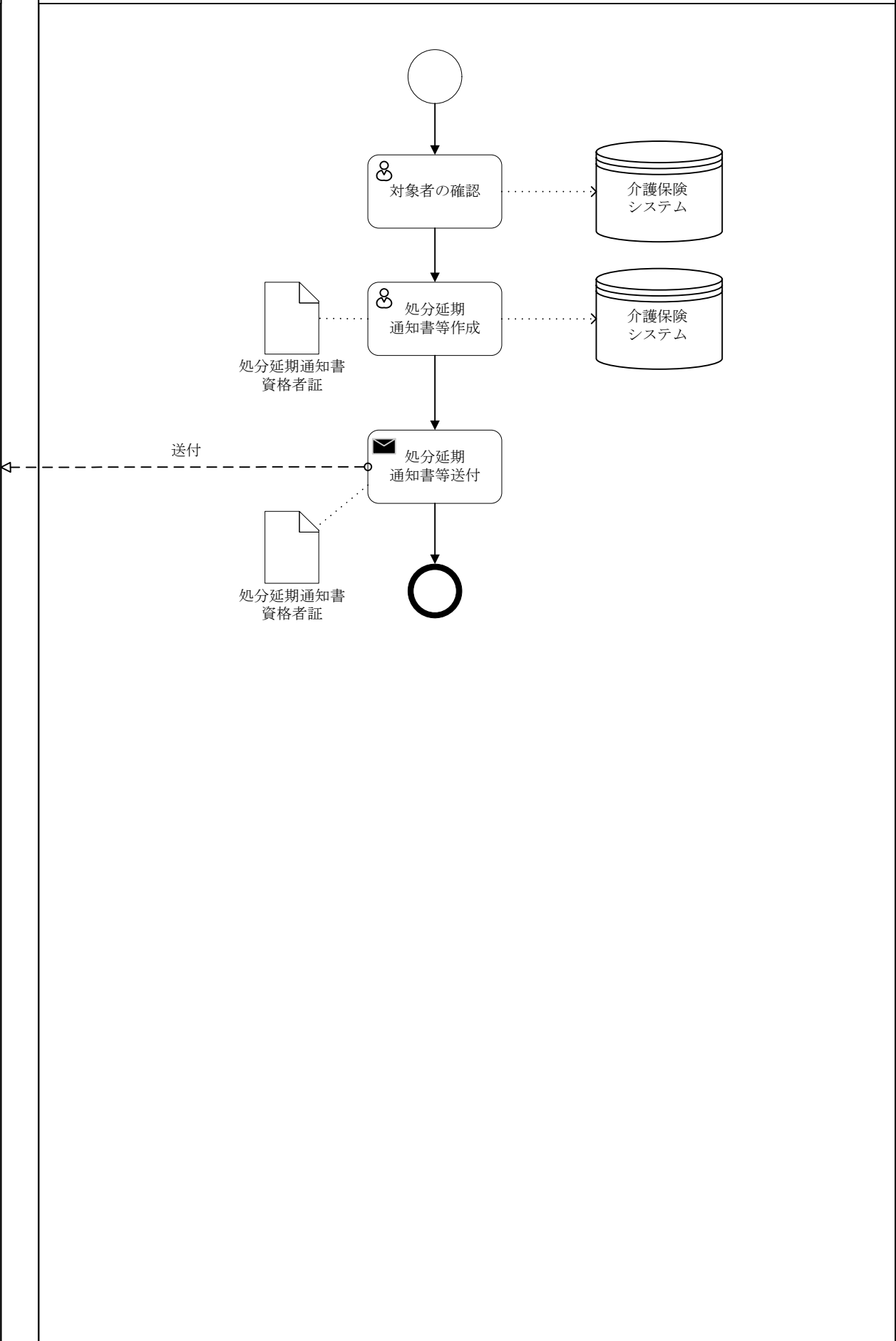

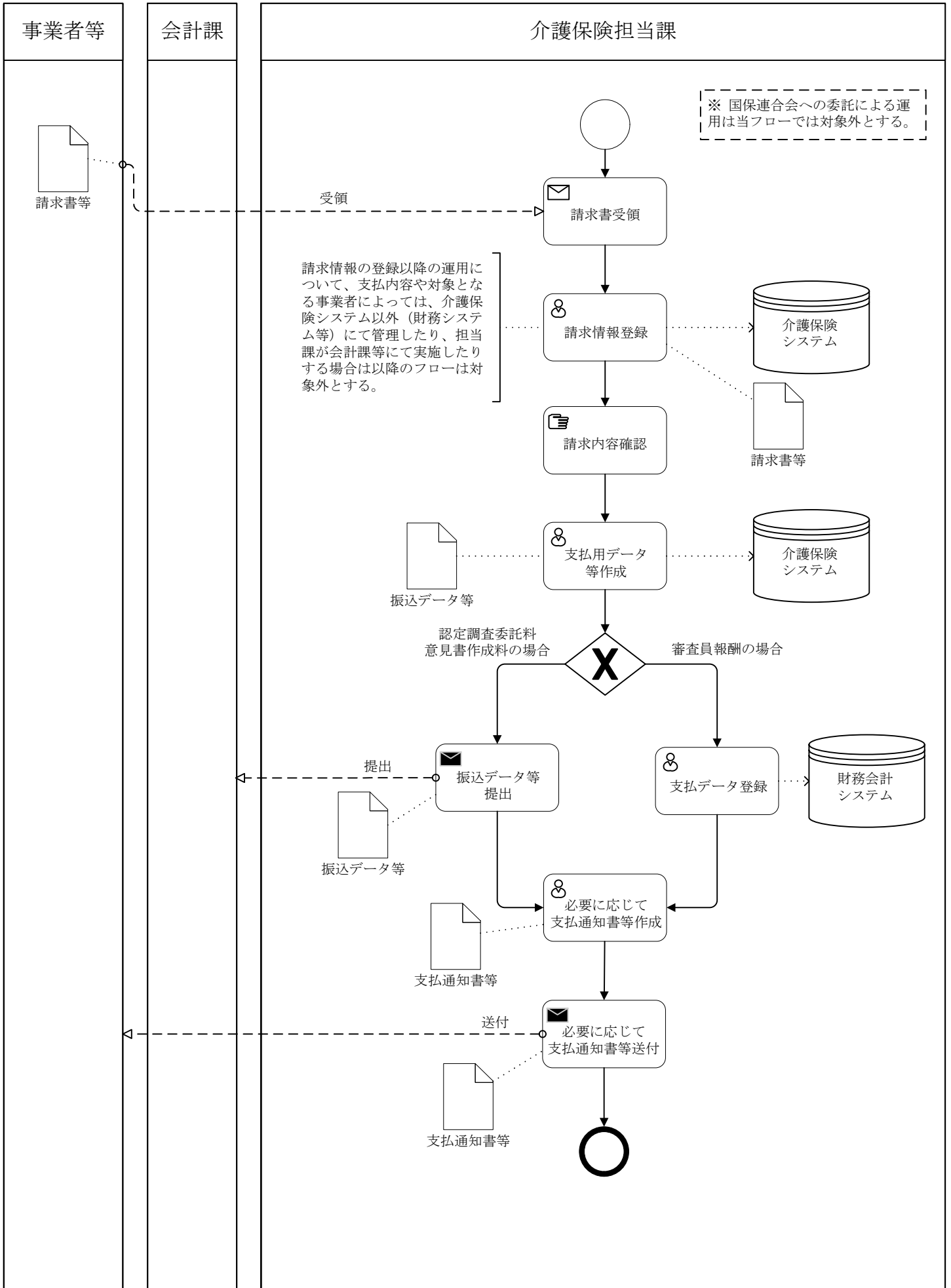

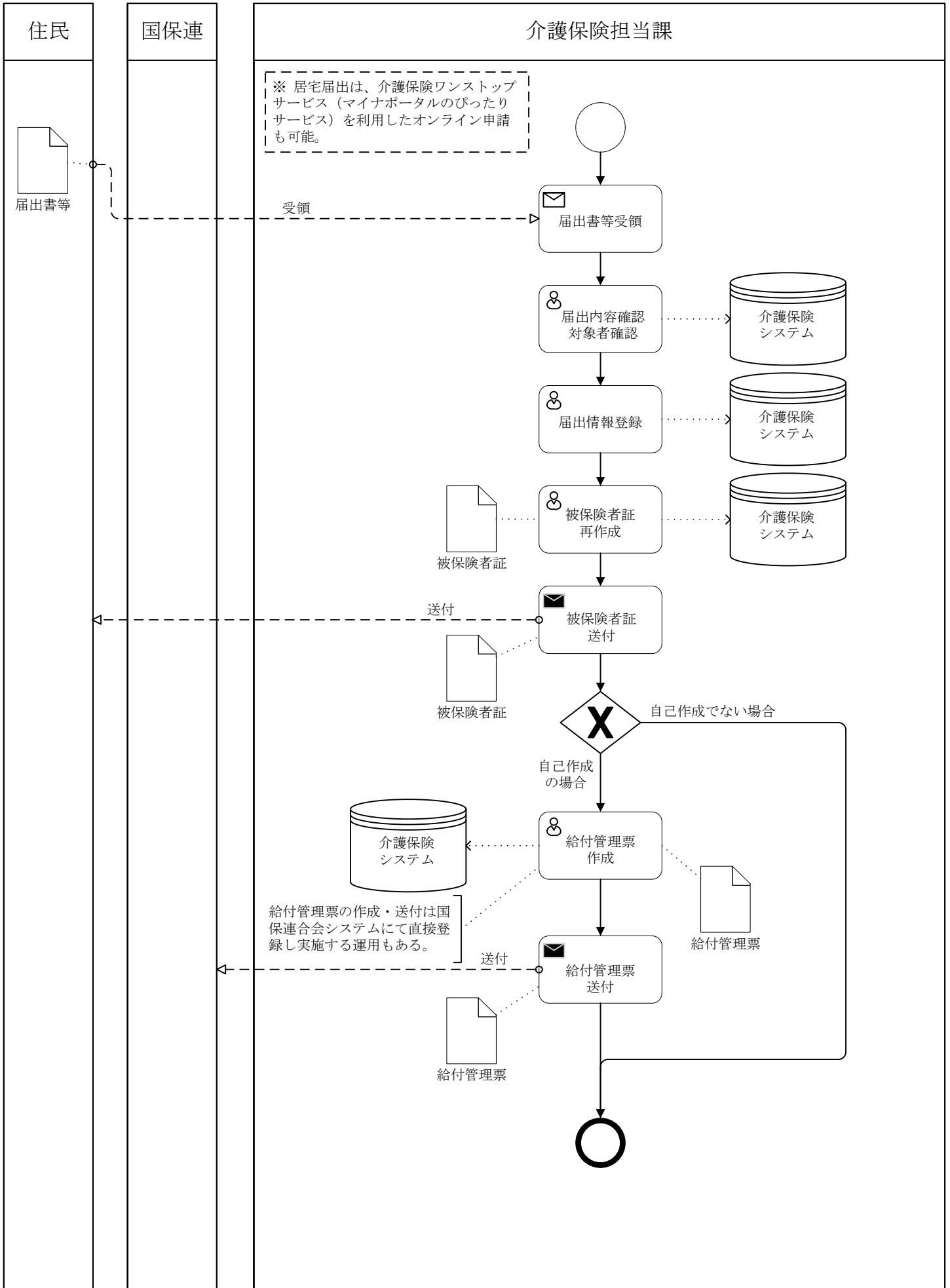

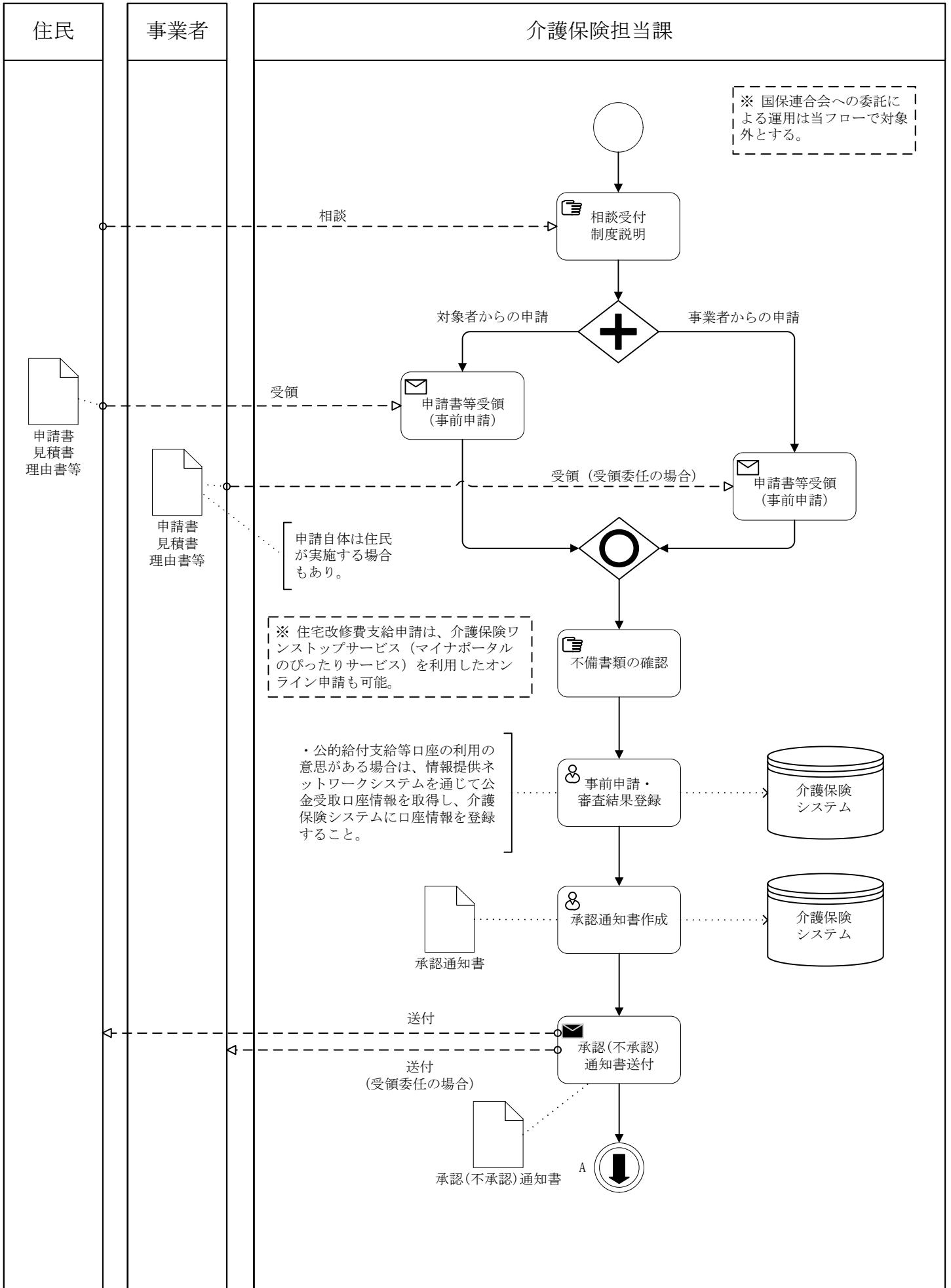

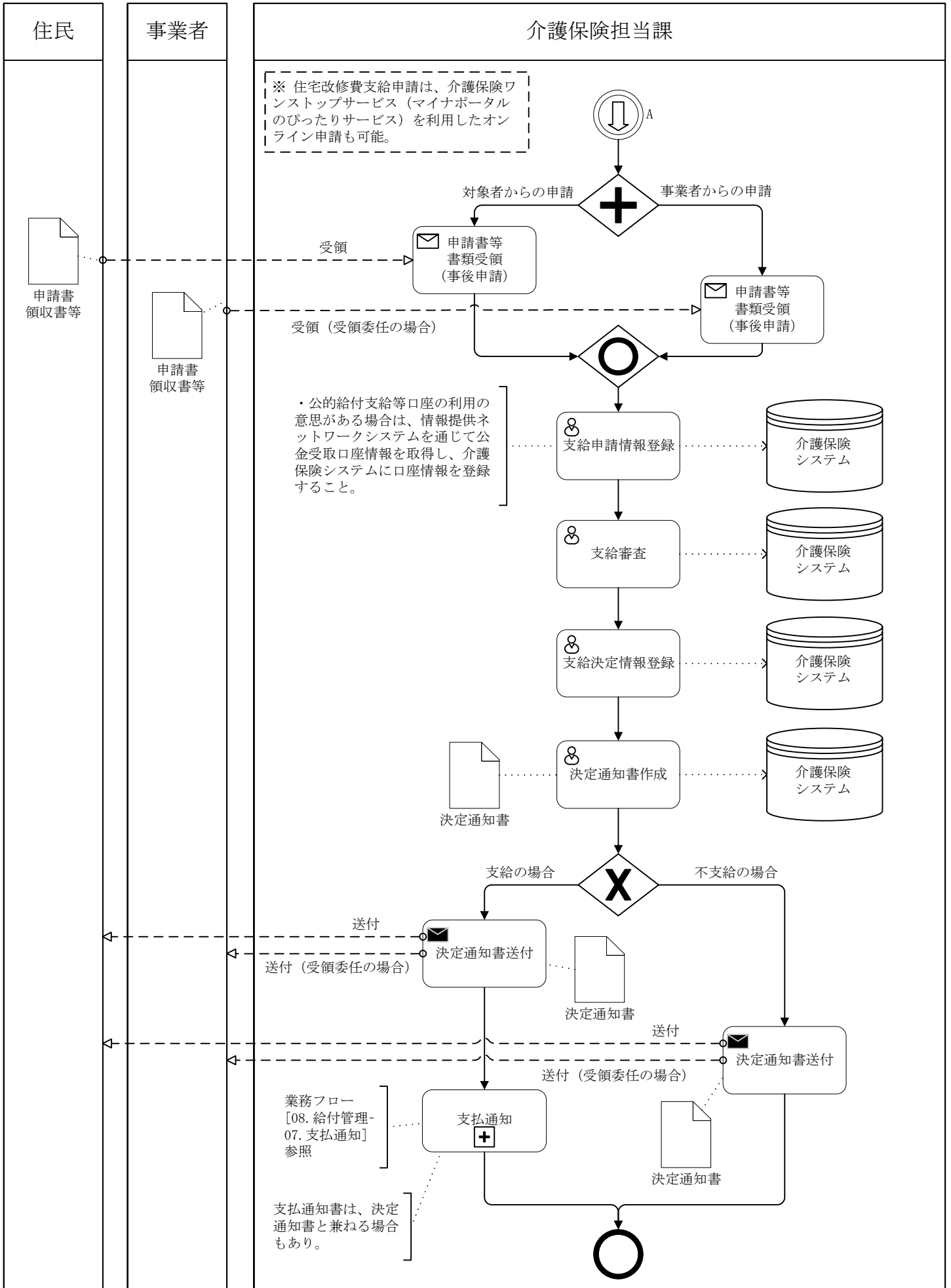

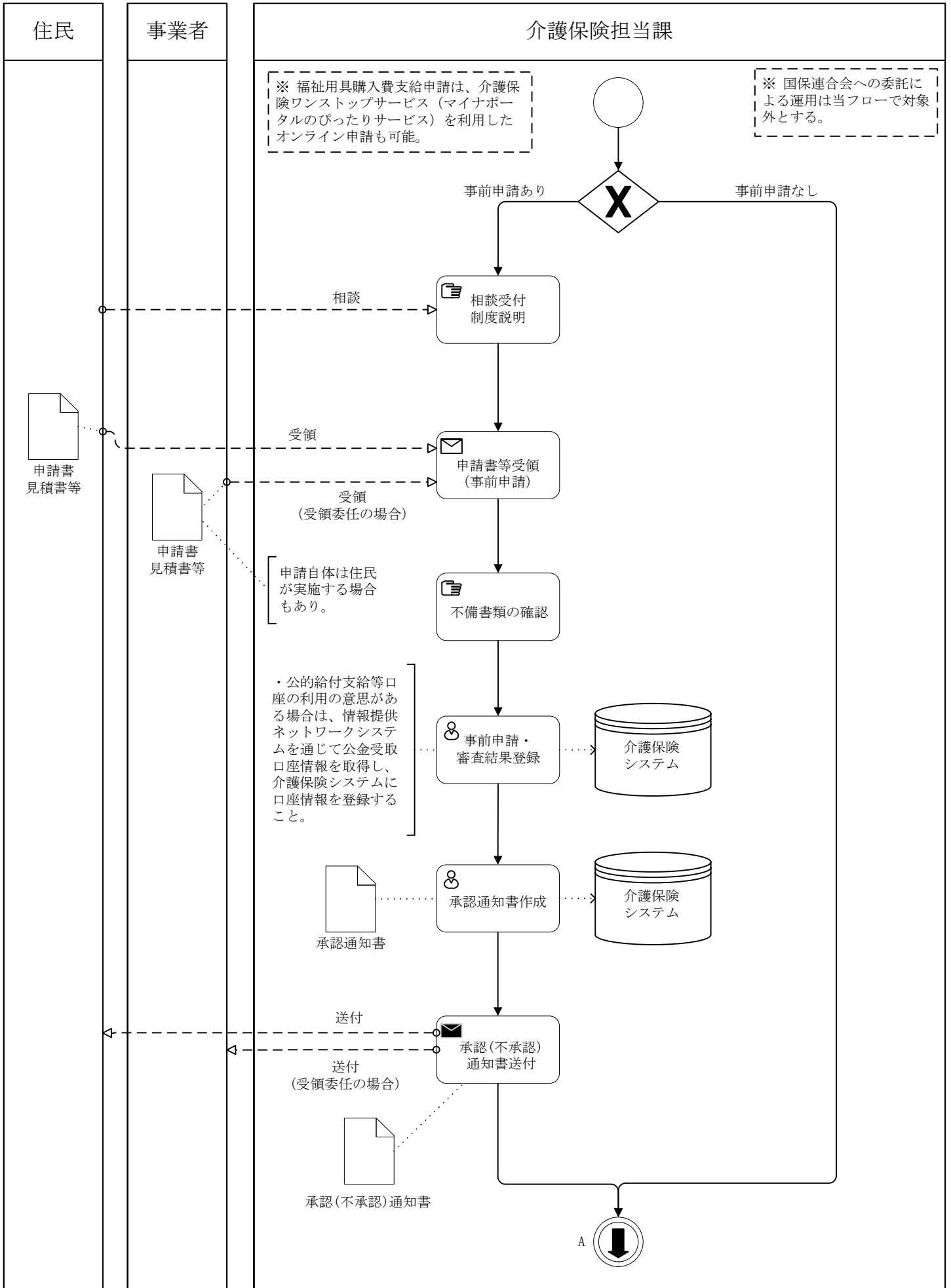

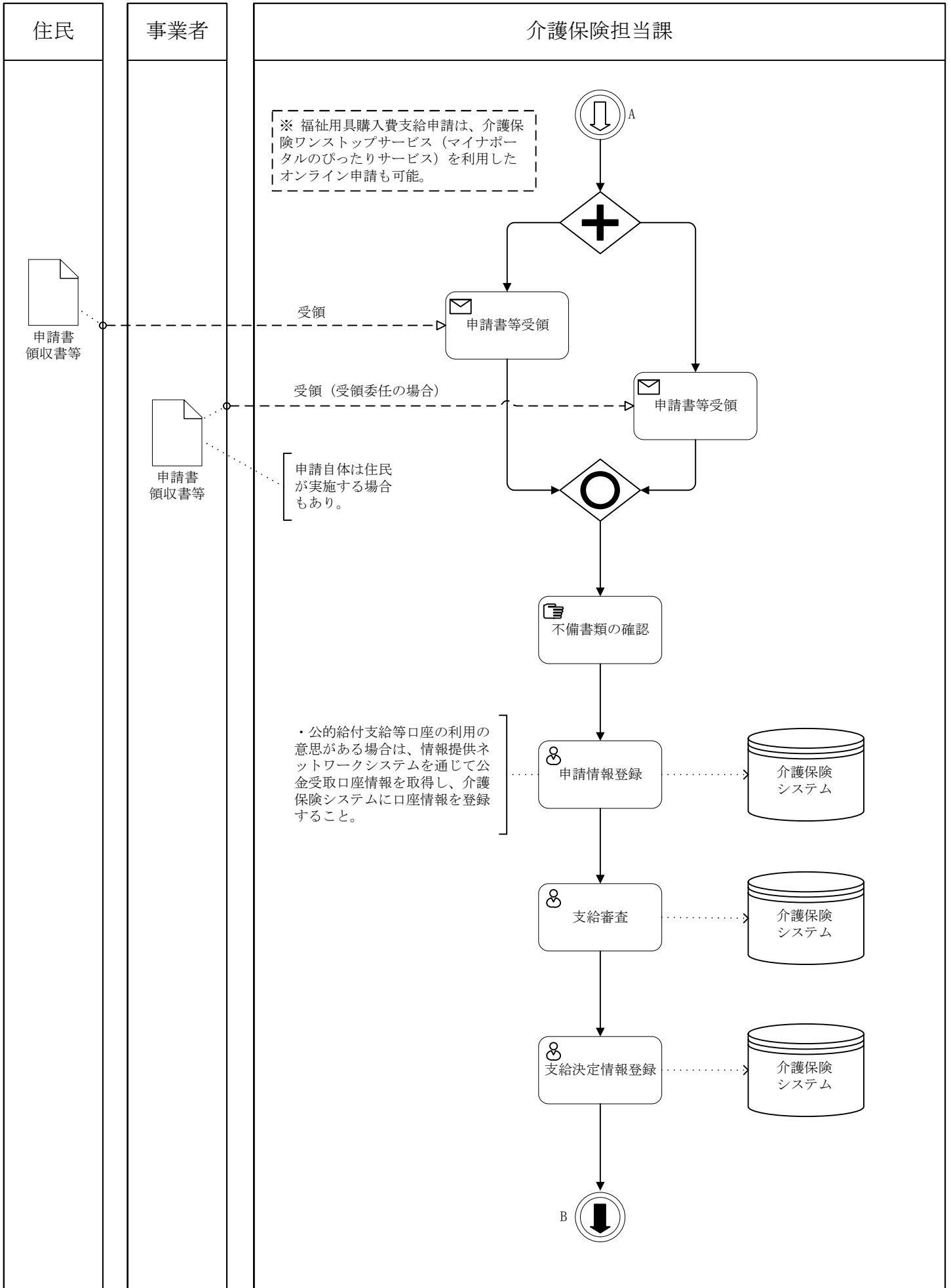

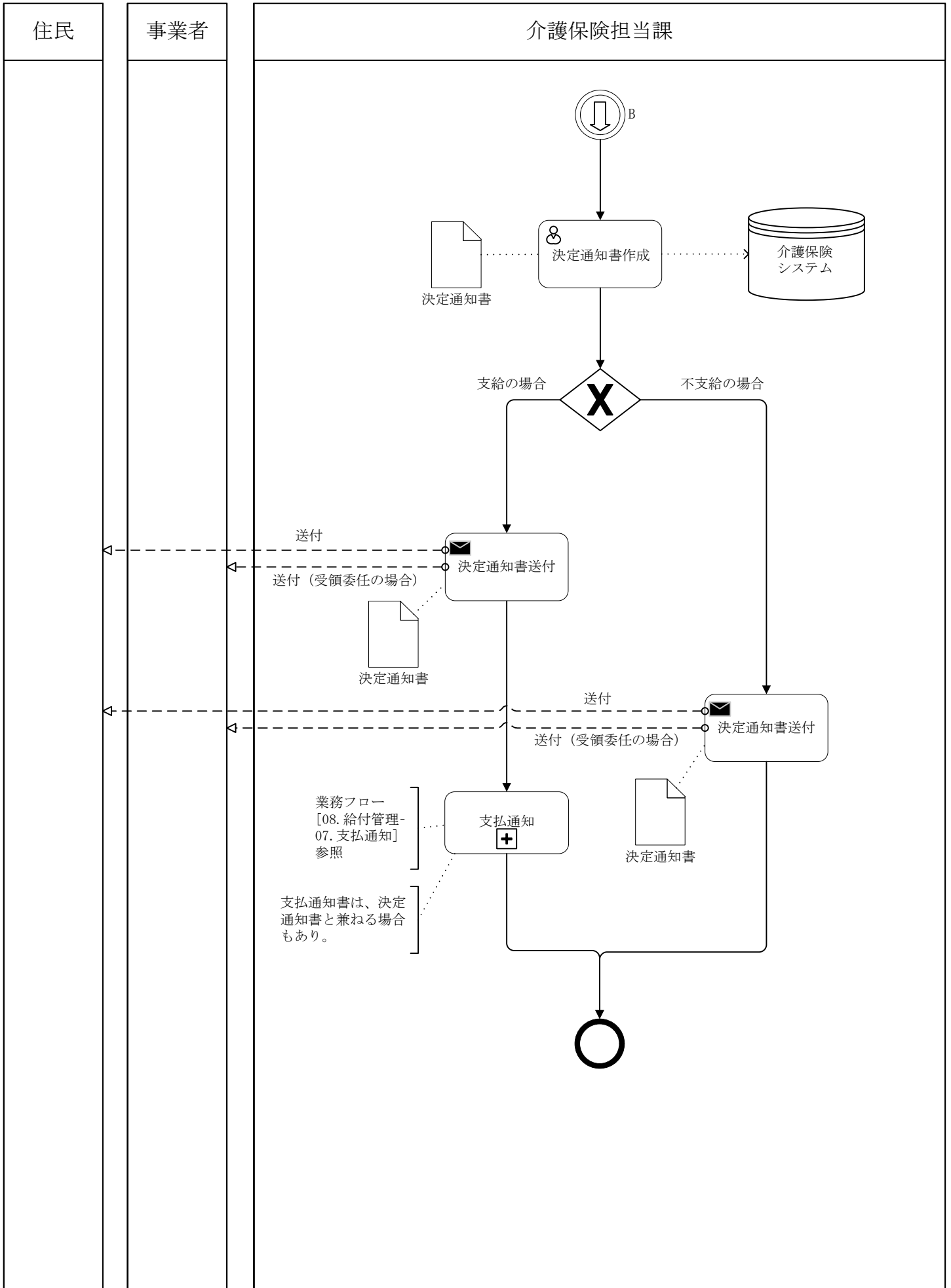

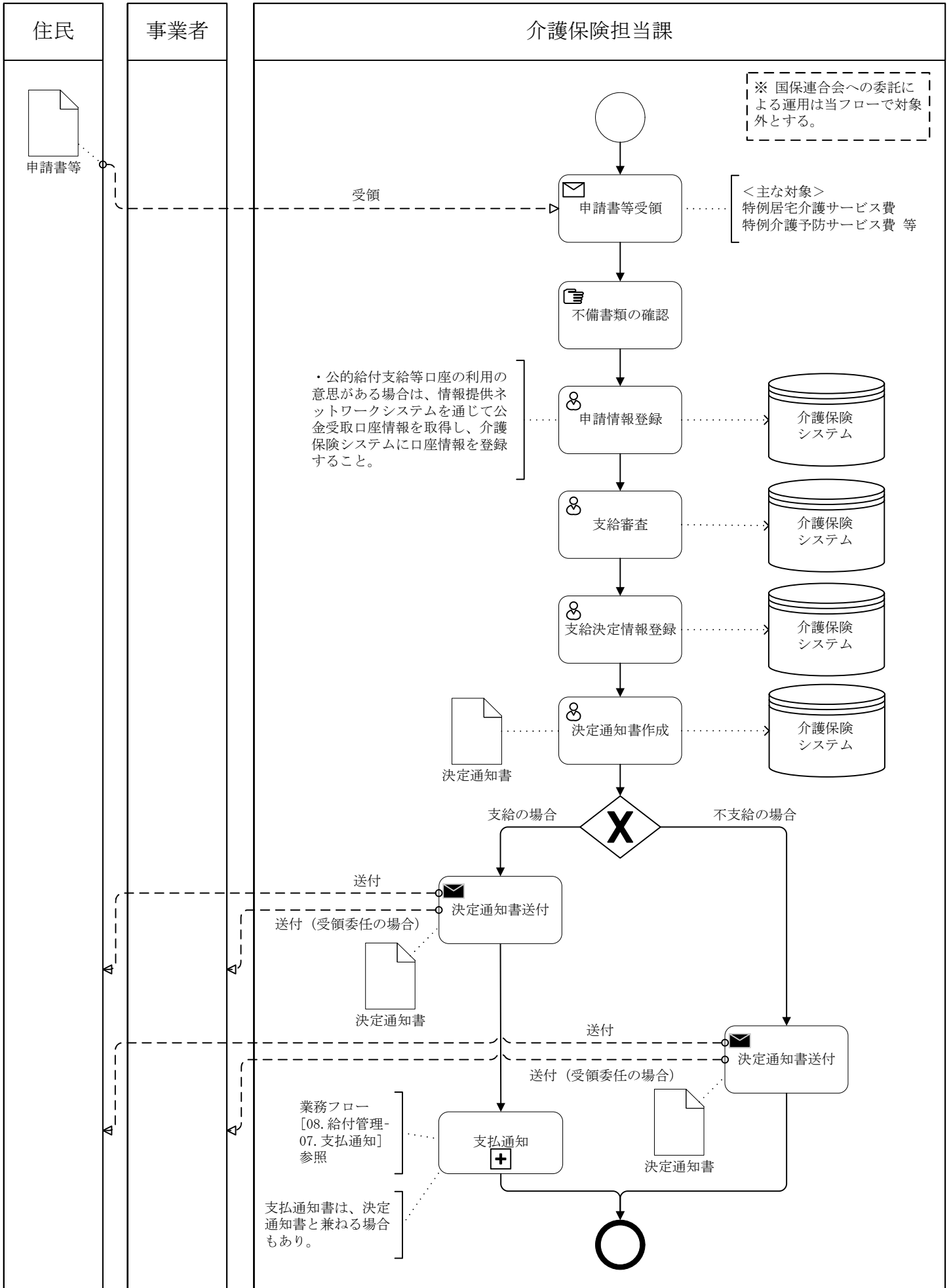

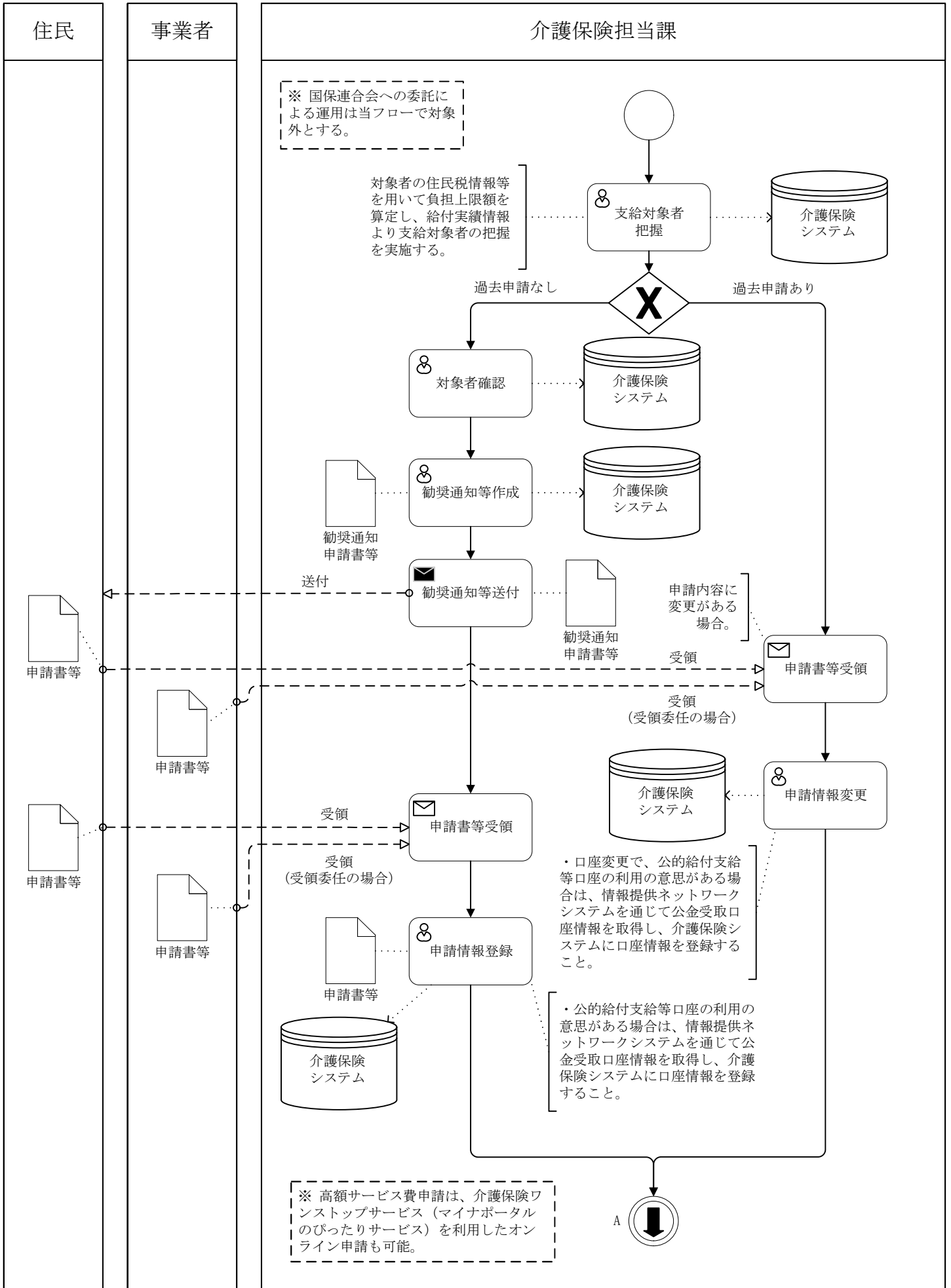

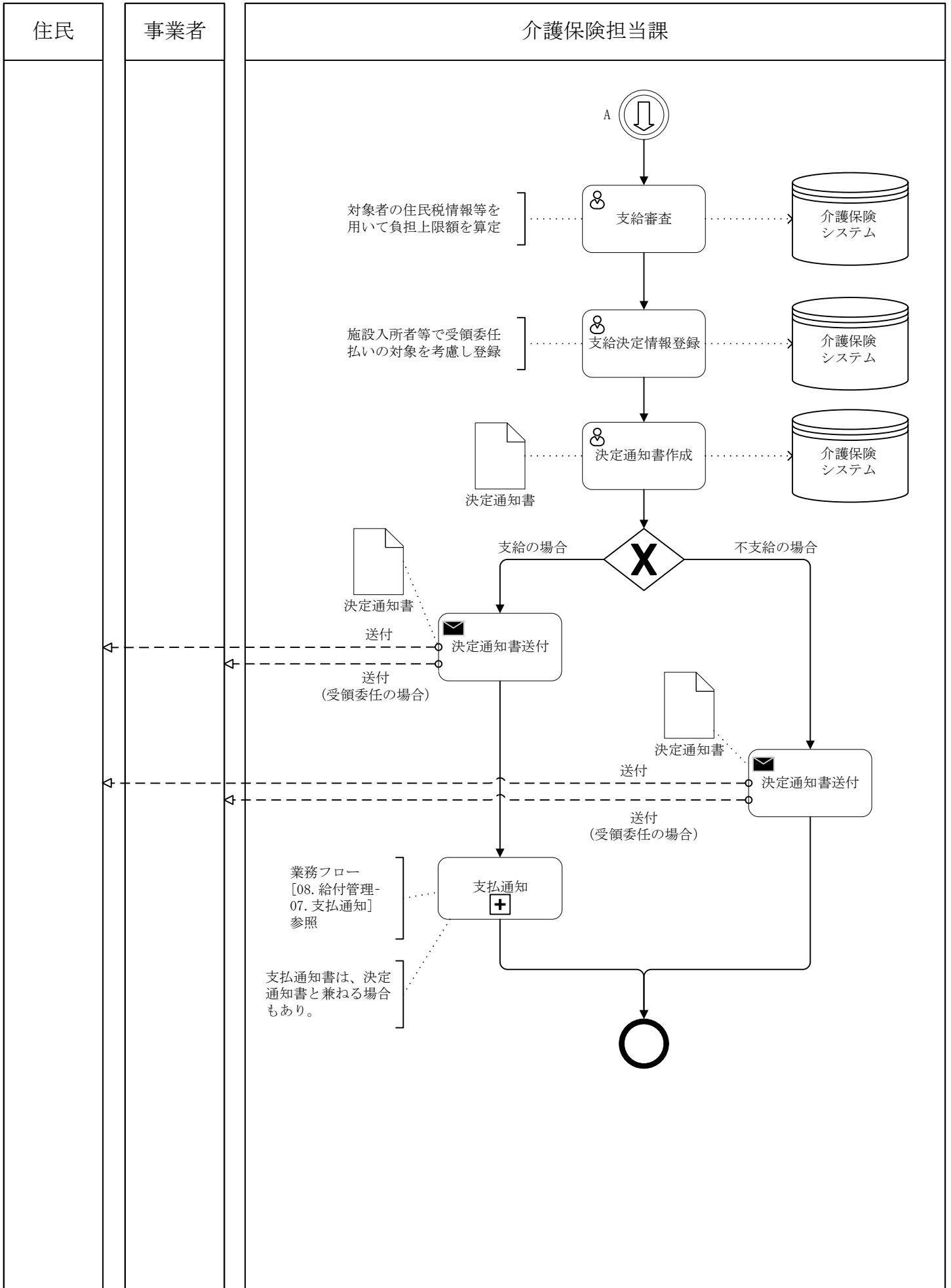

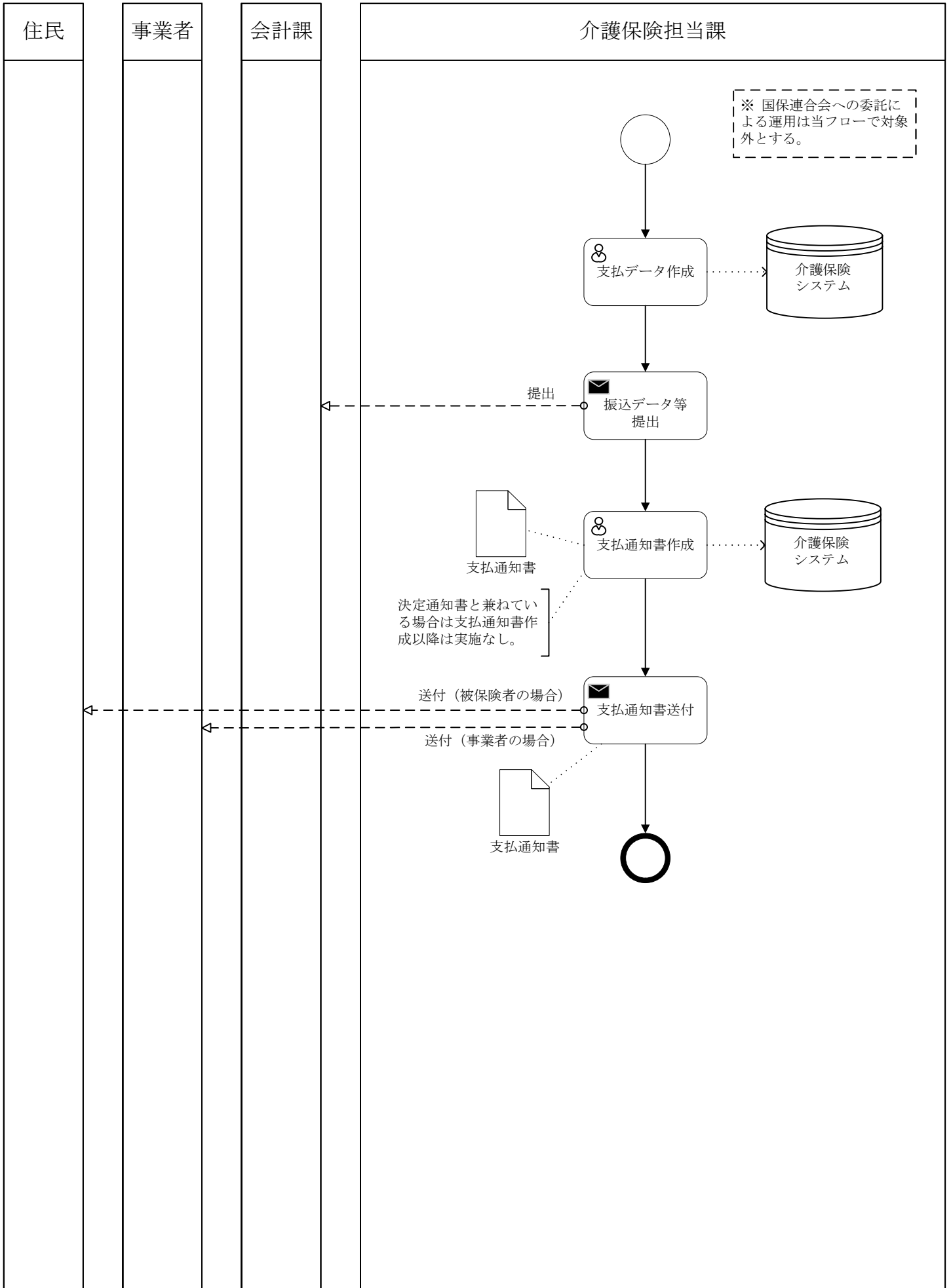

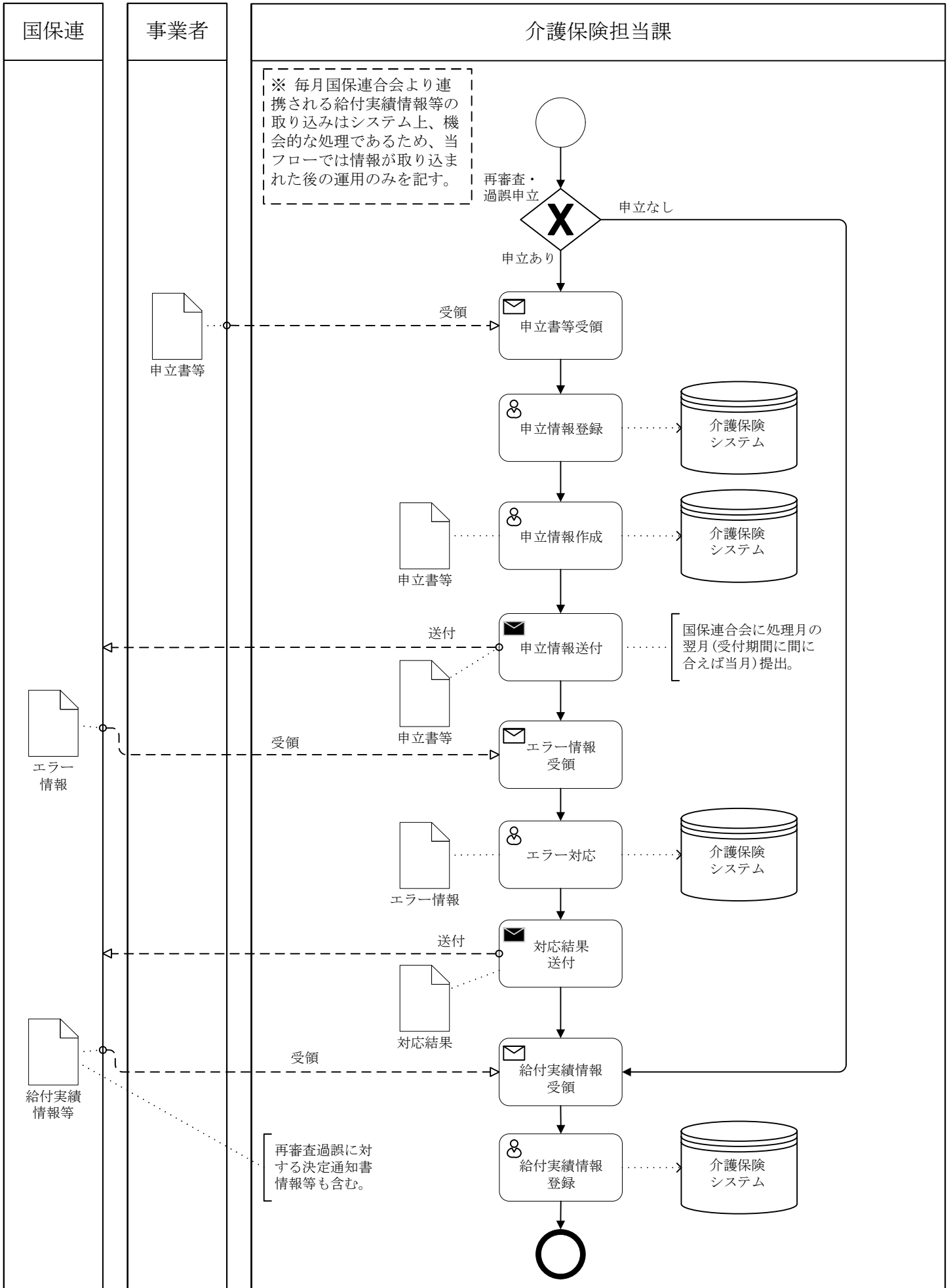

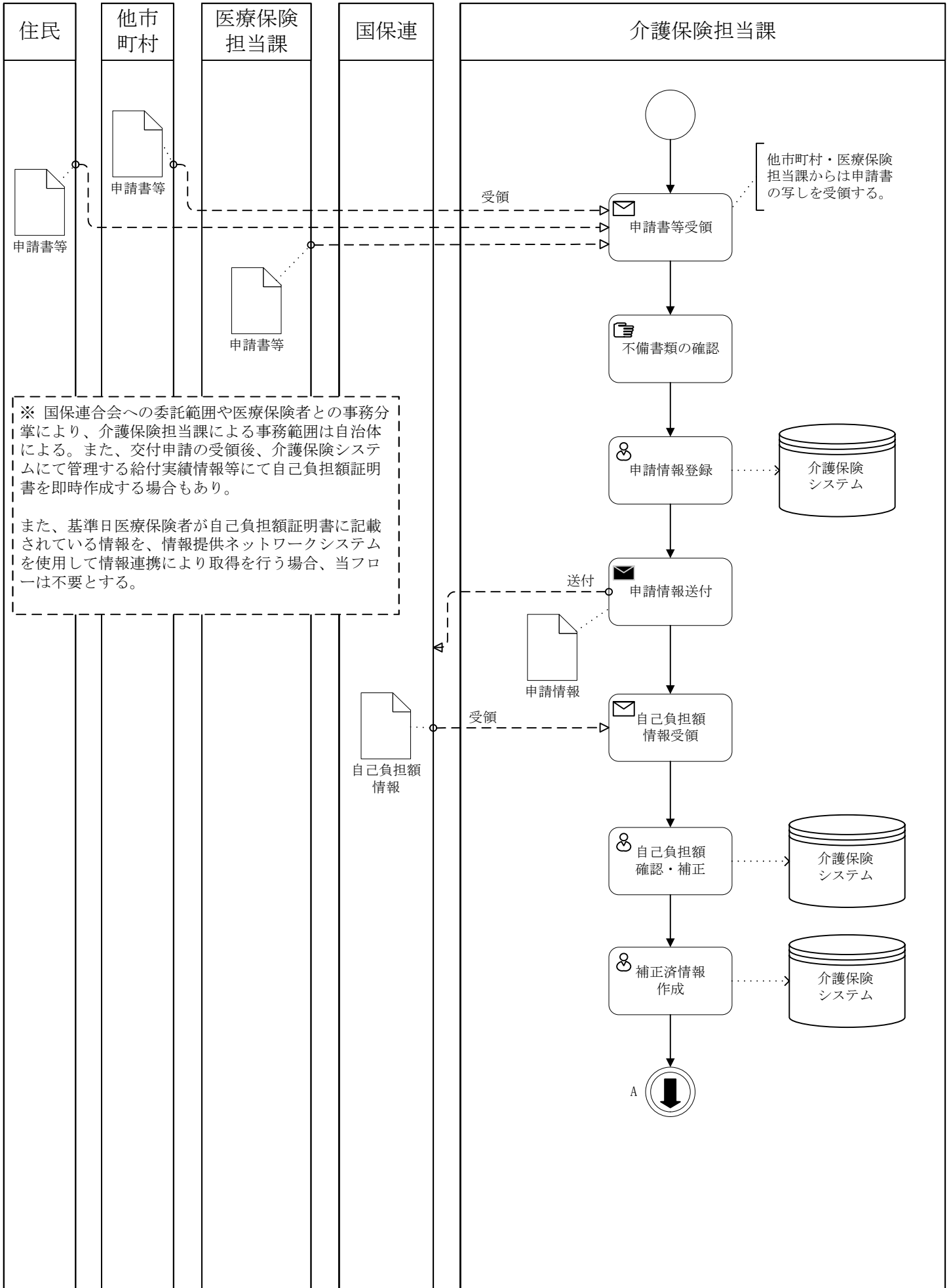

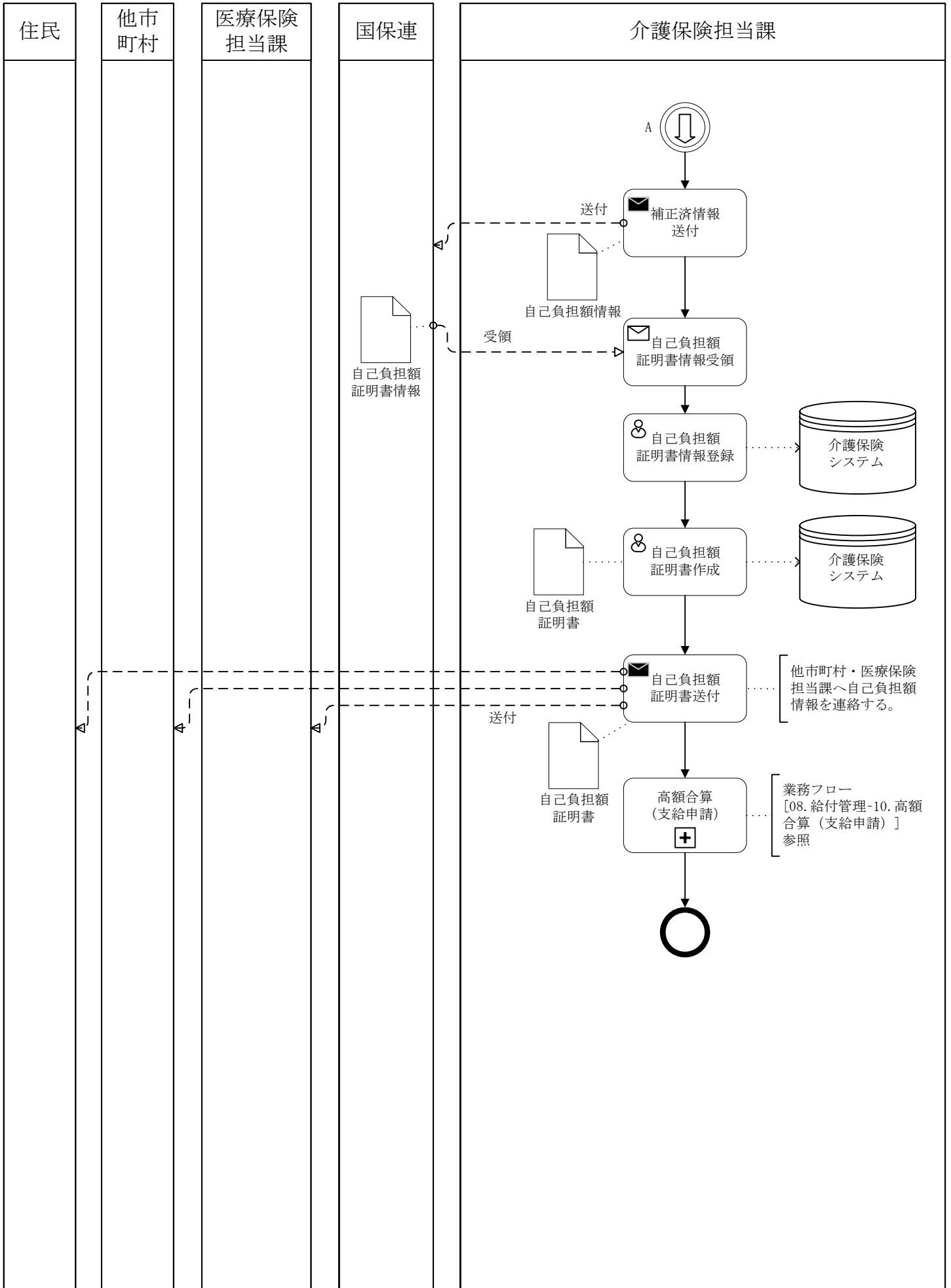

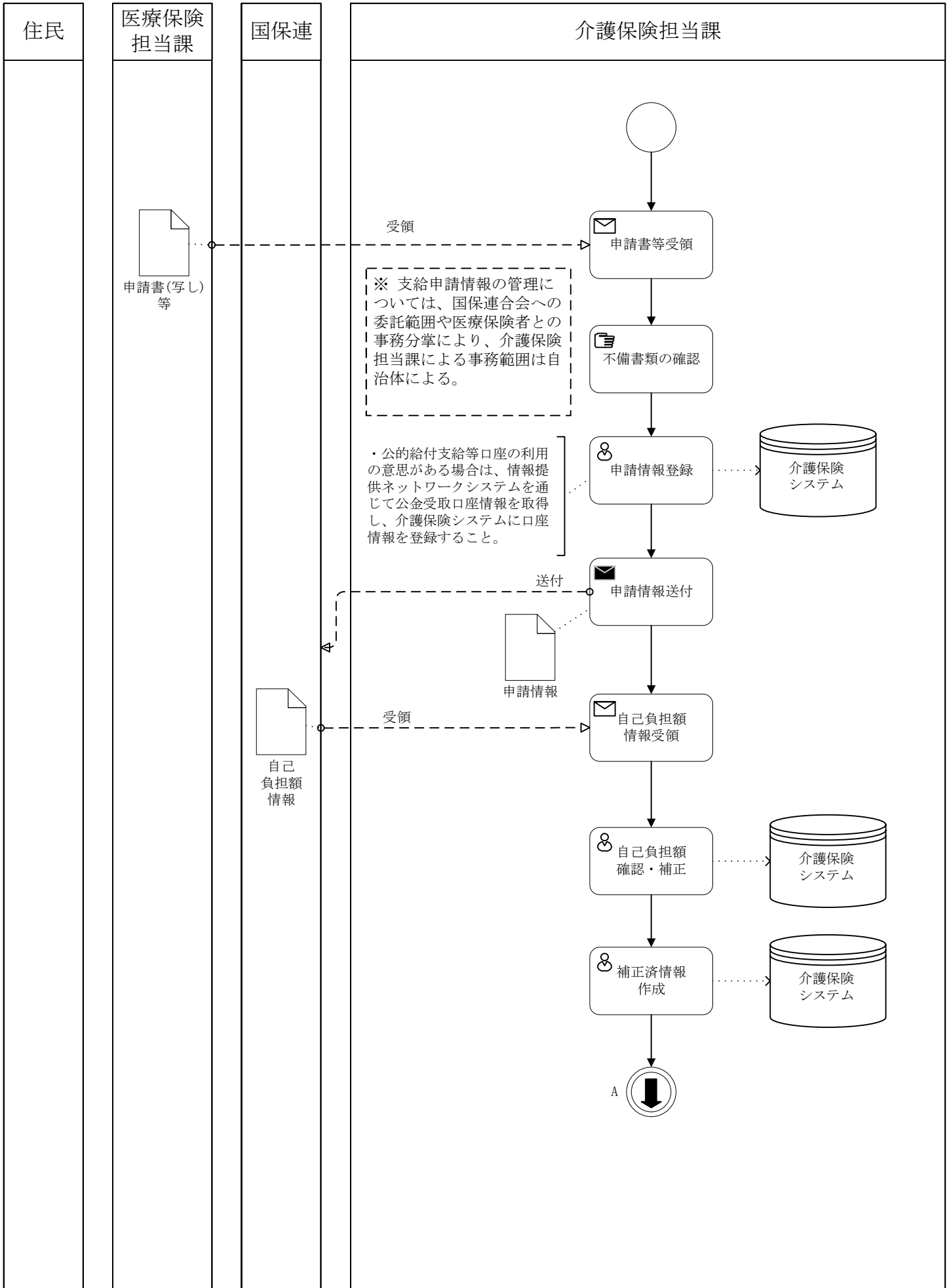

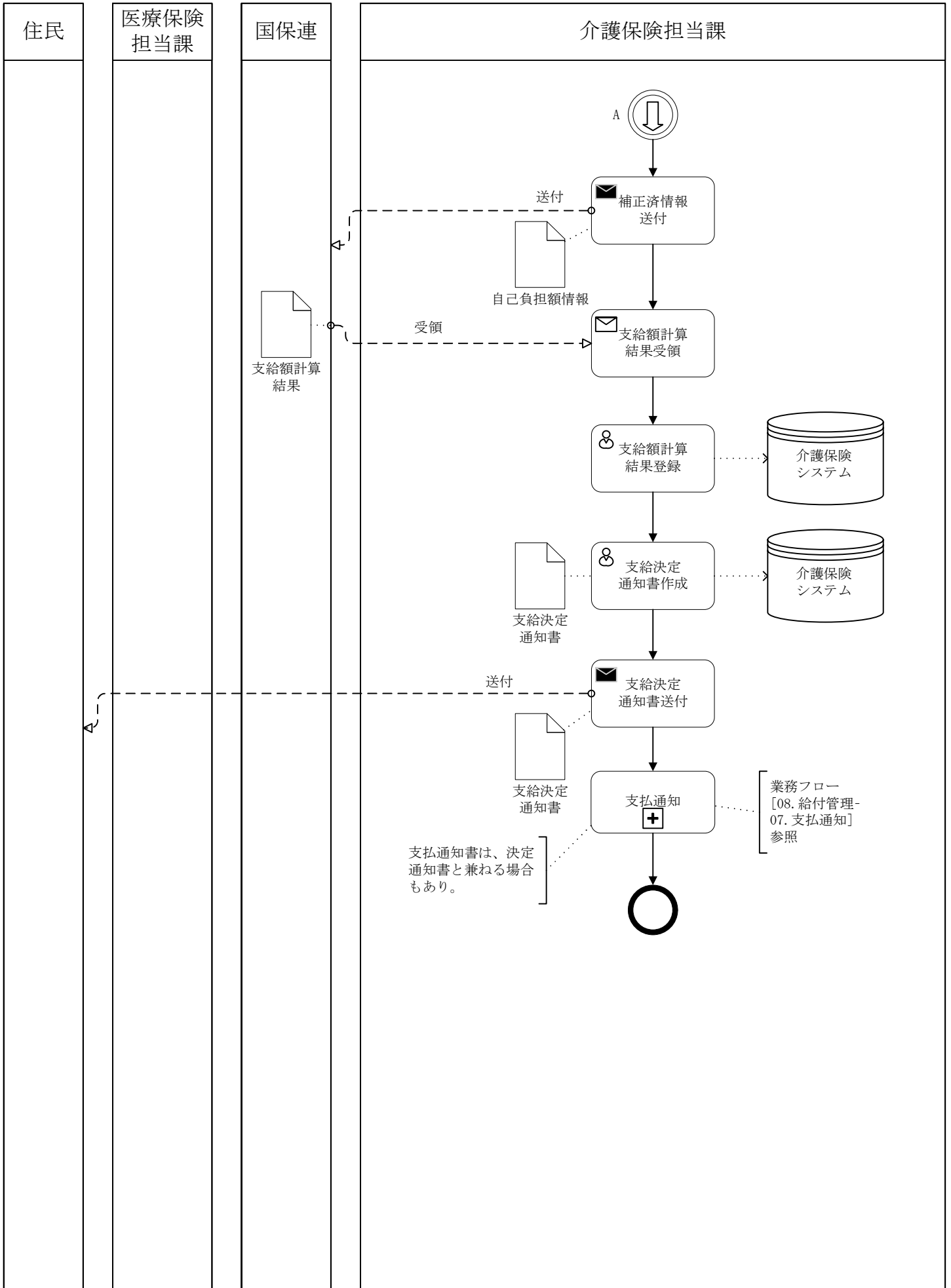

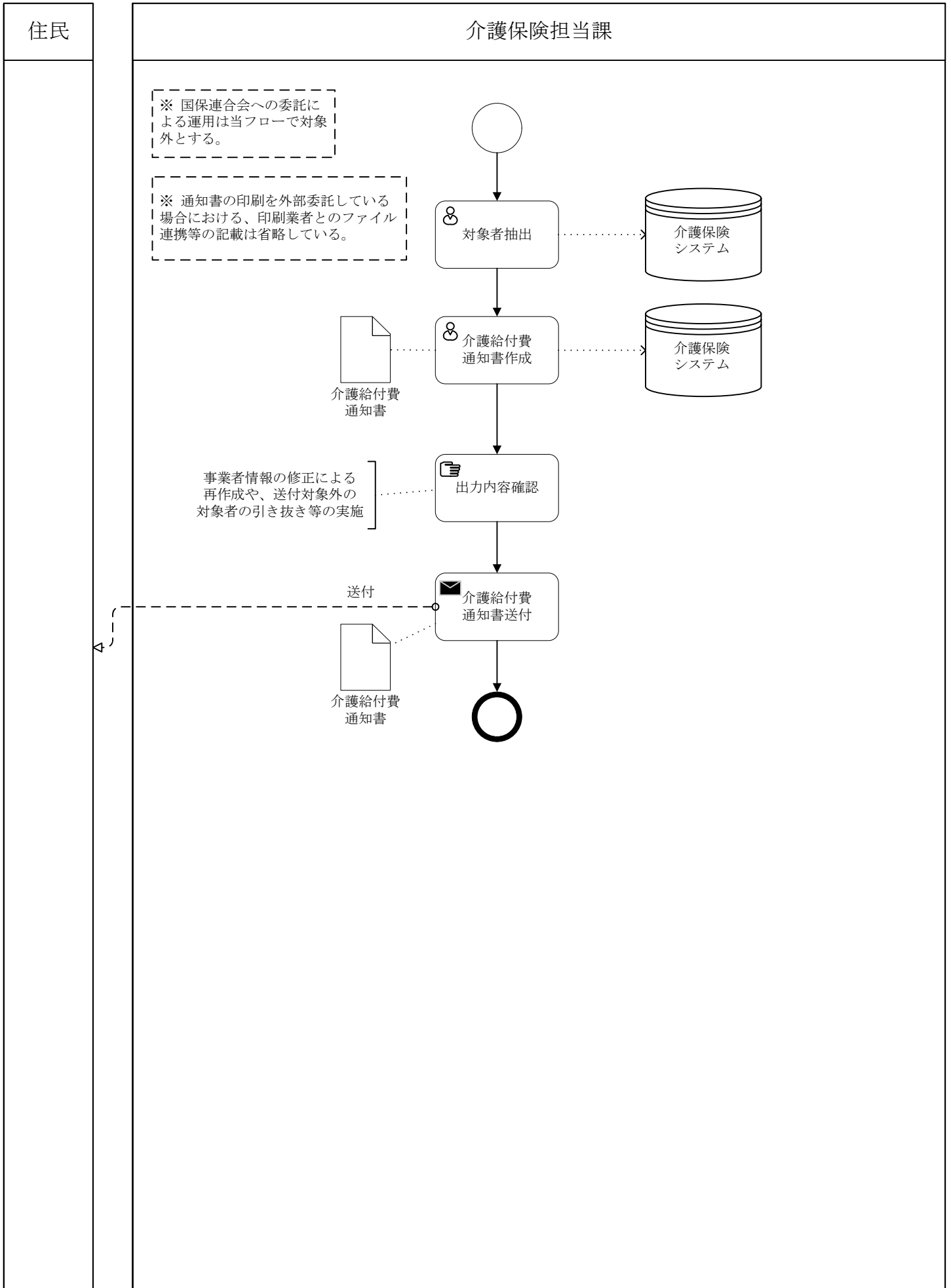

関係機関

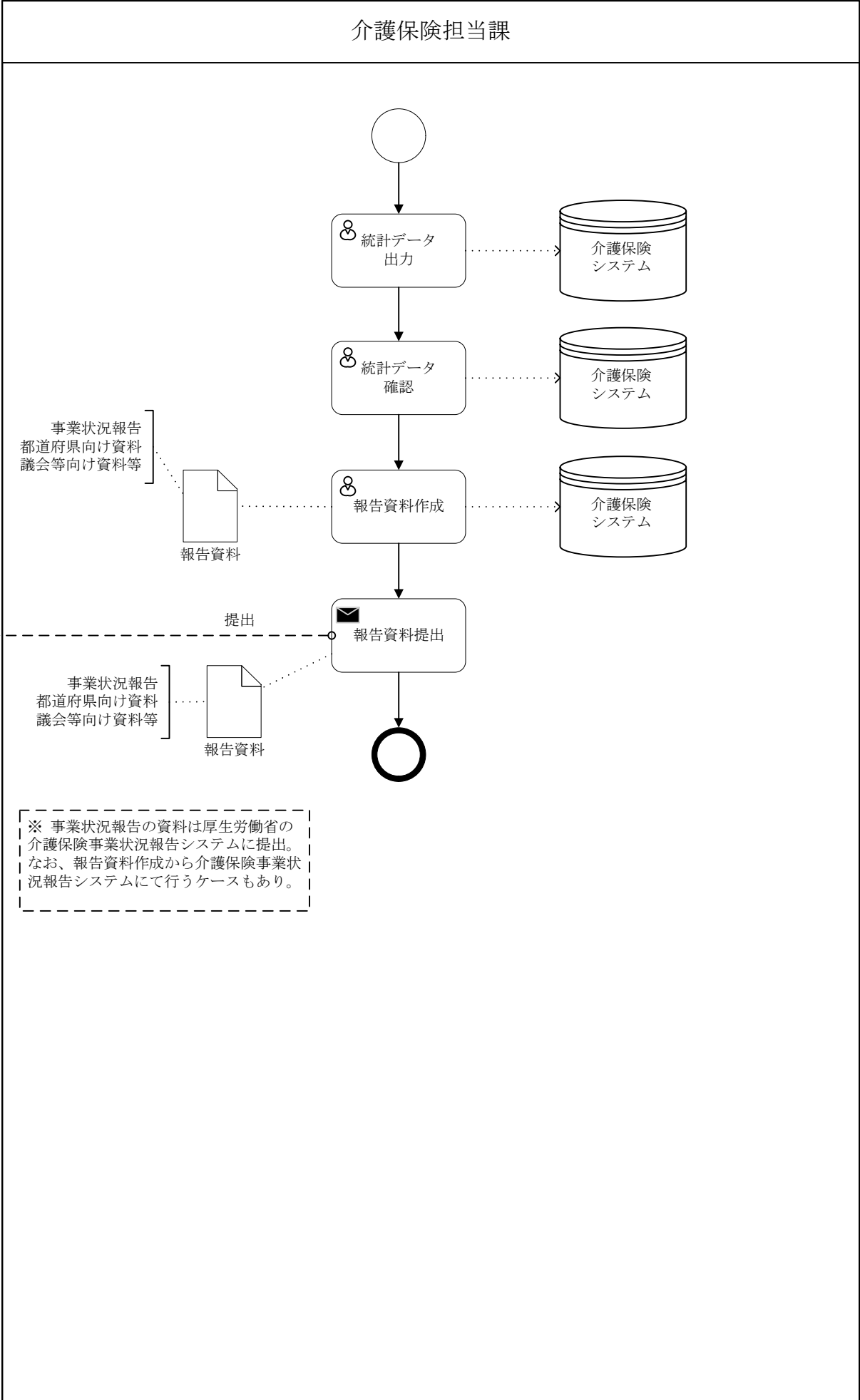

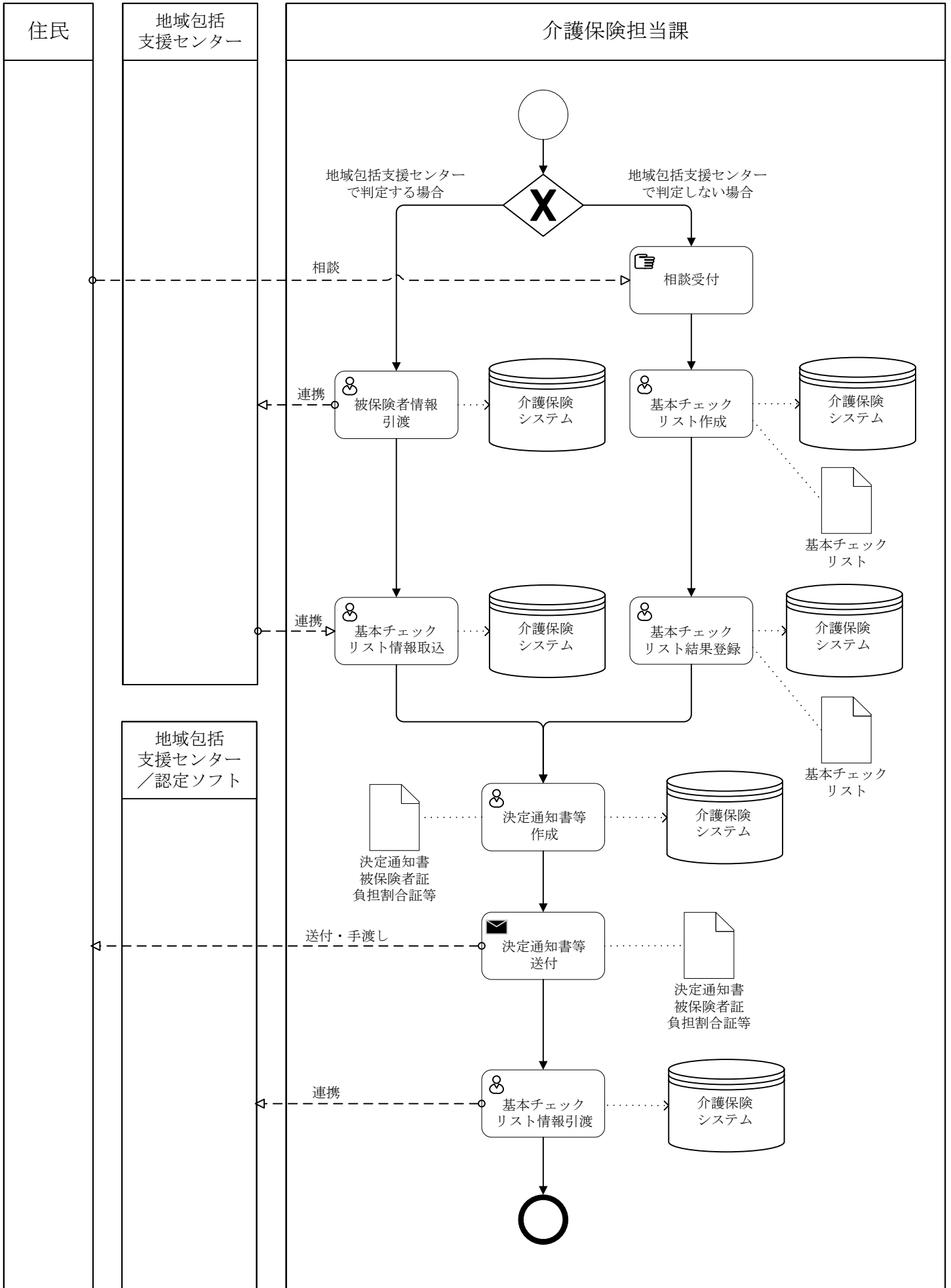

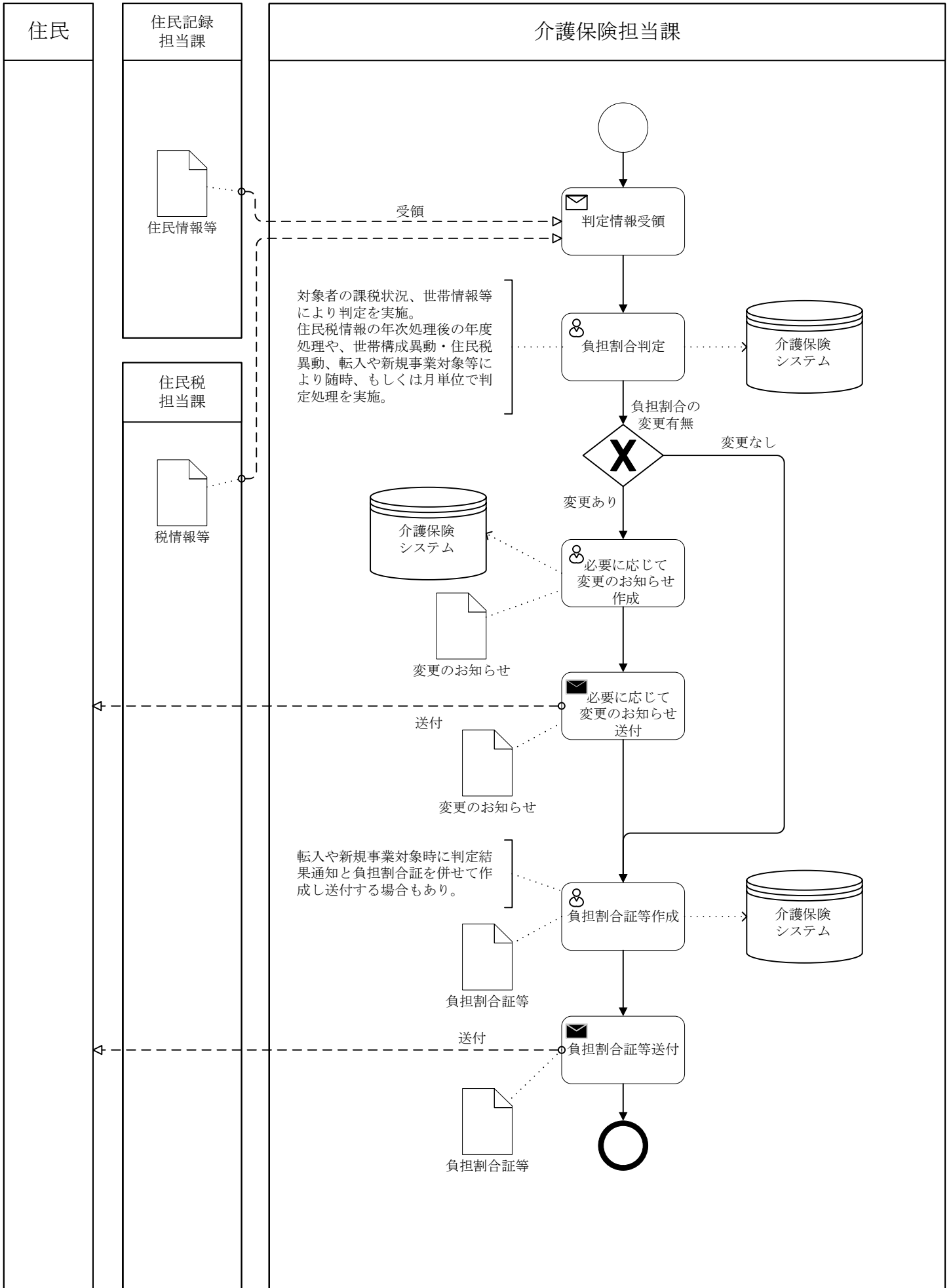

国保連合会

介護保険担当課

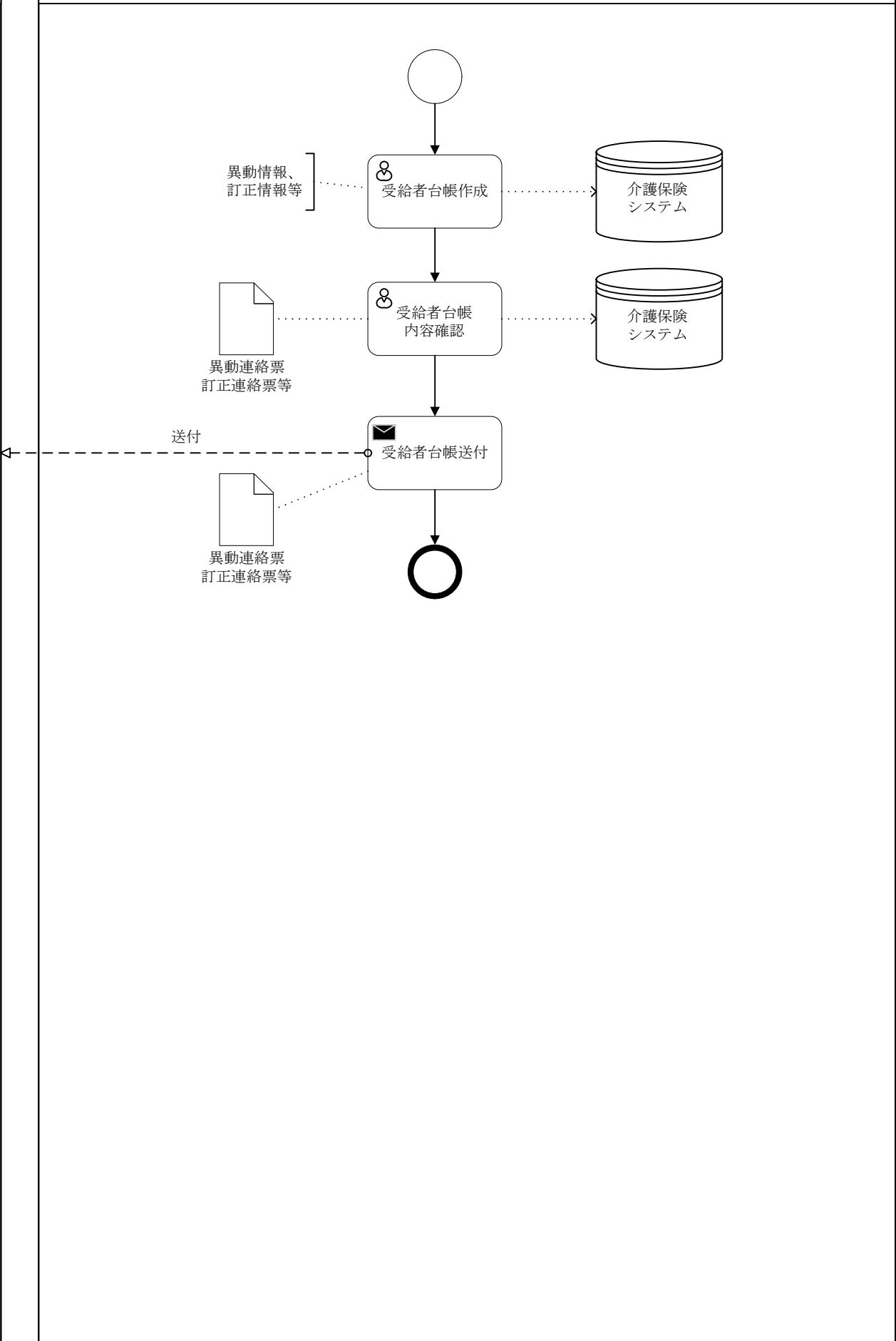

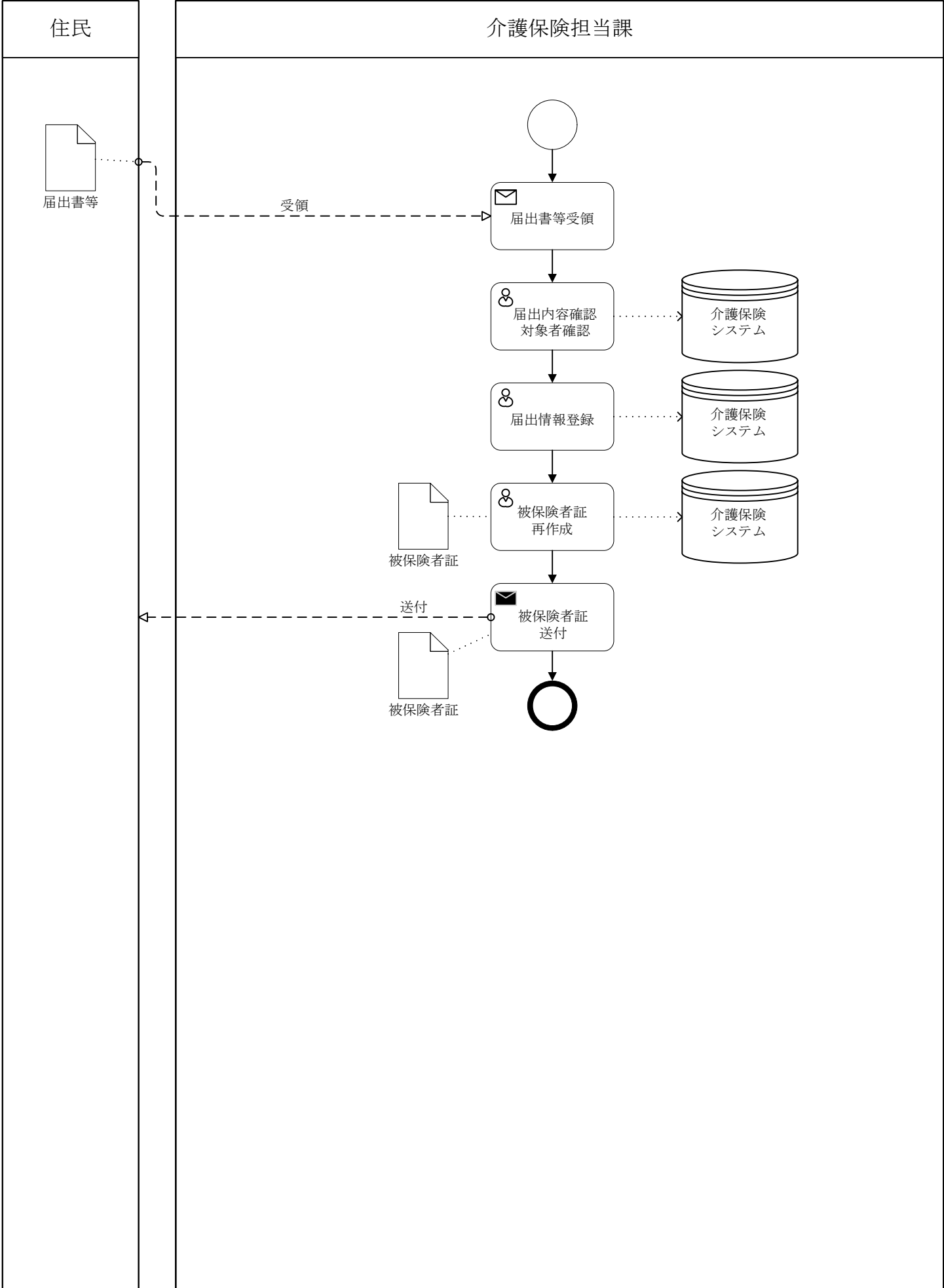

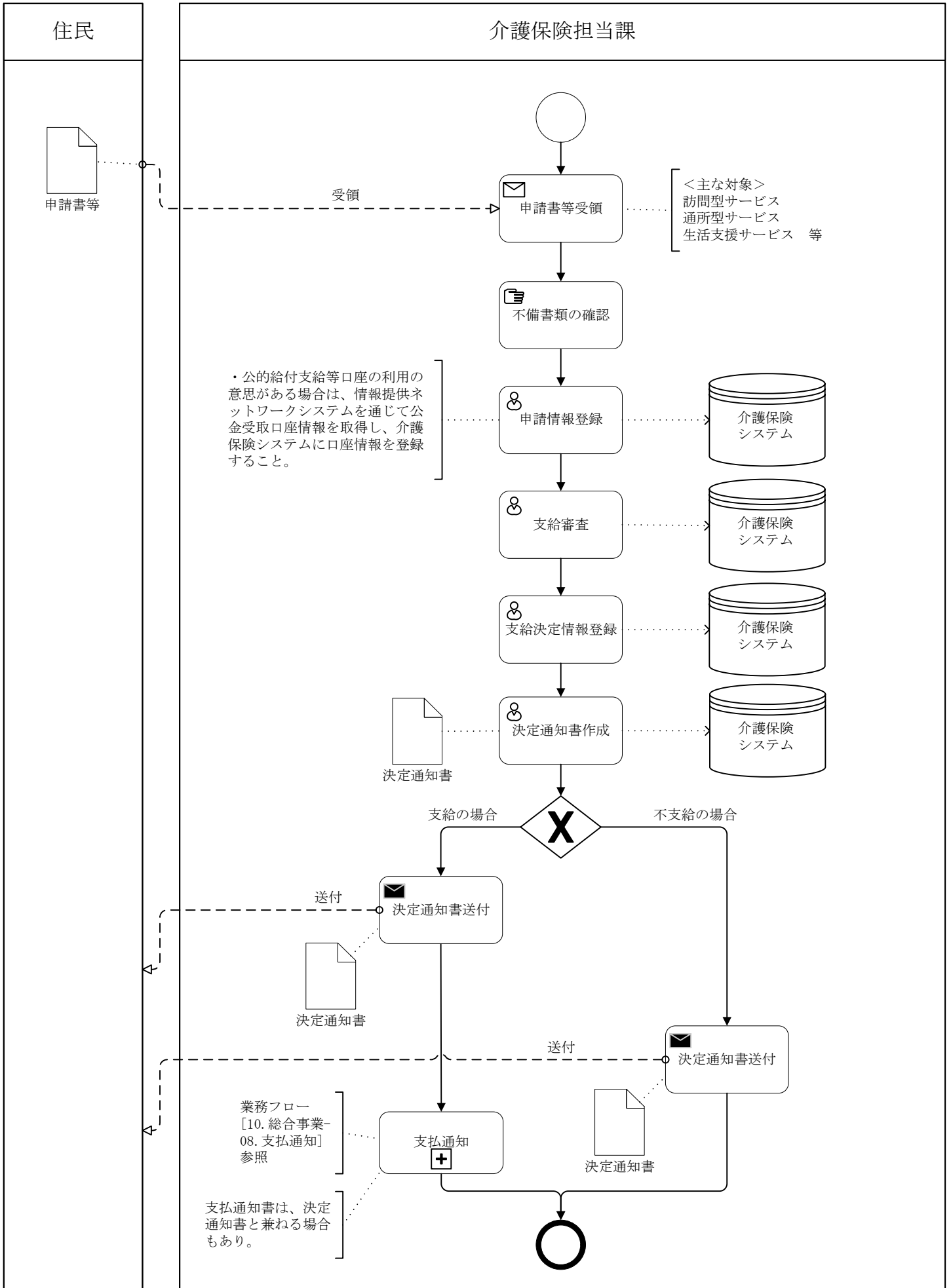

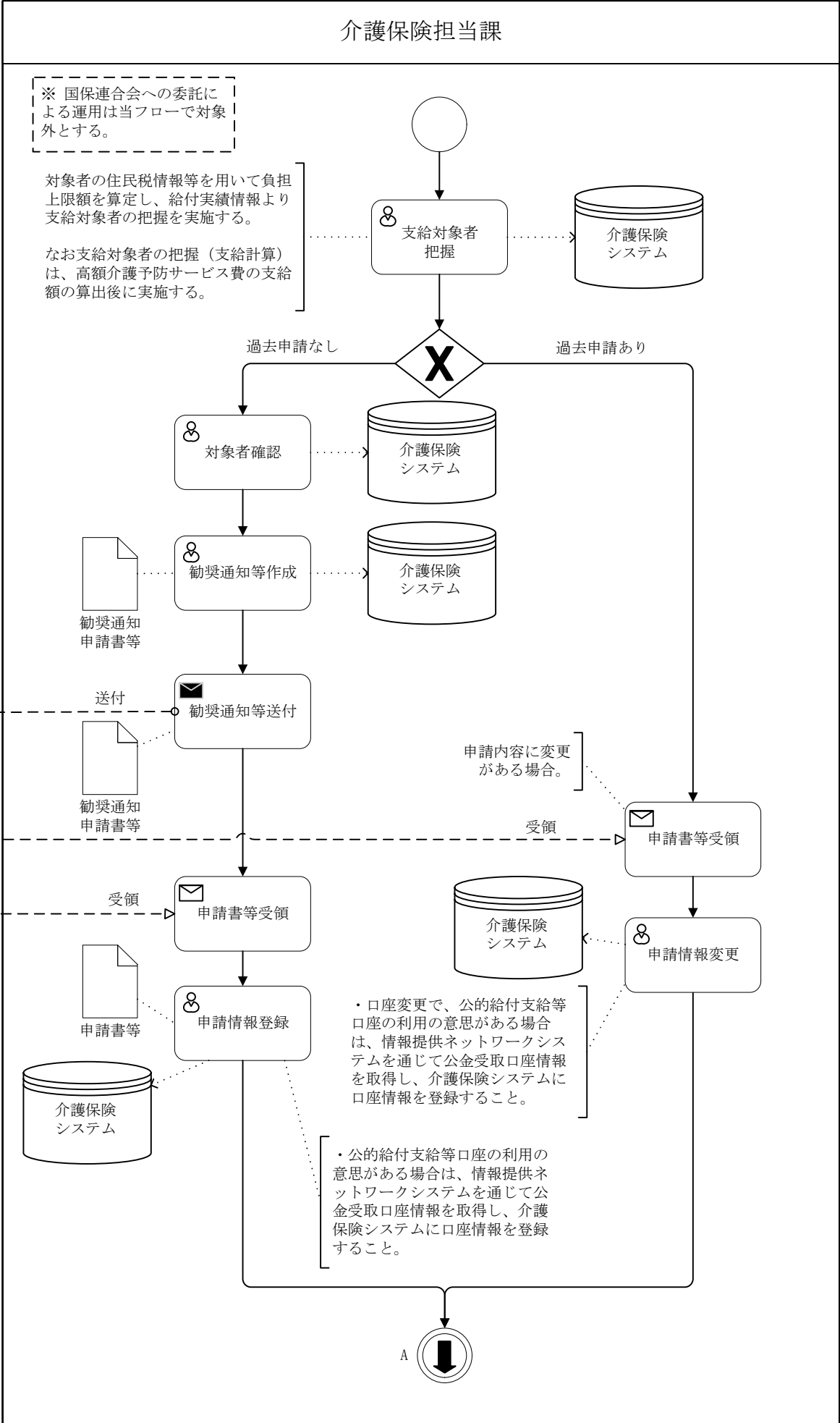
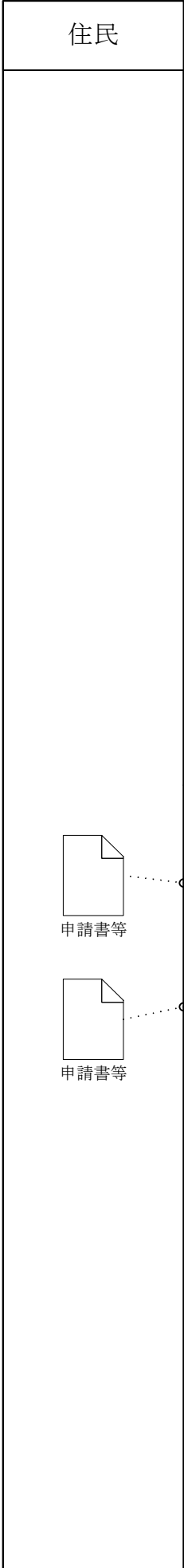

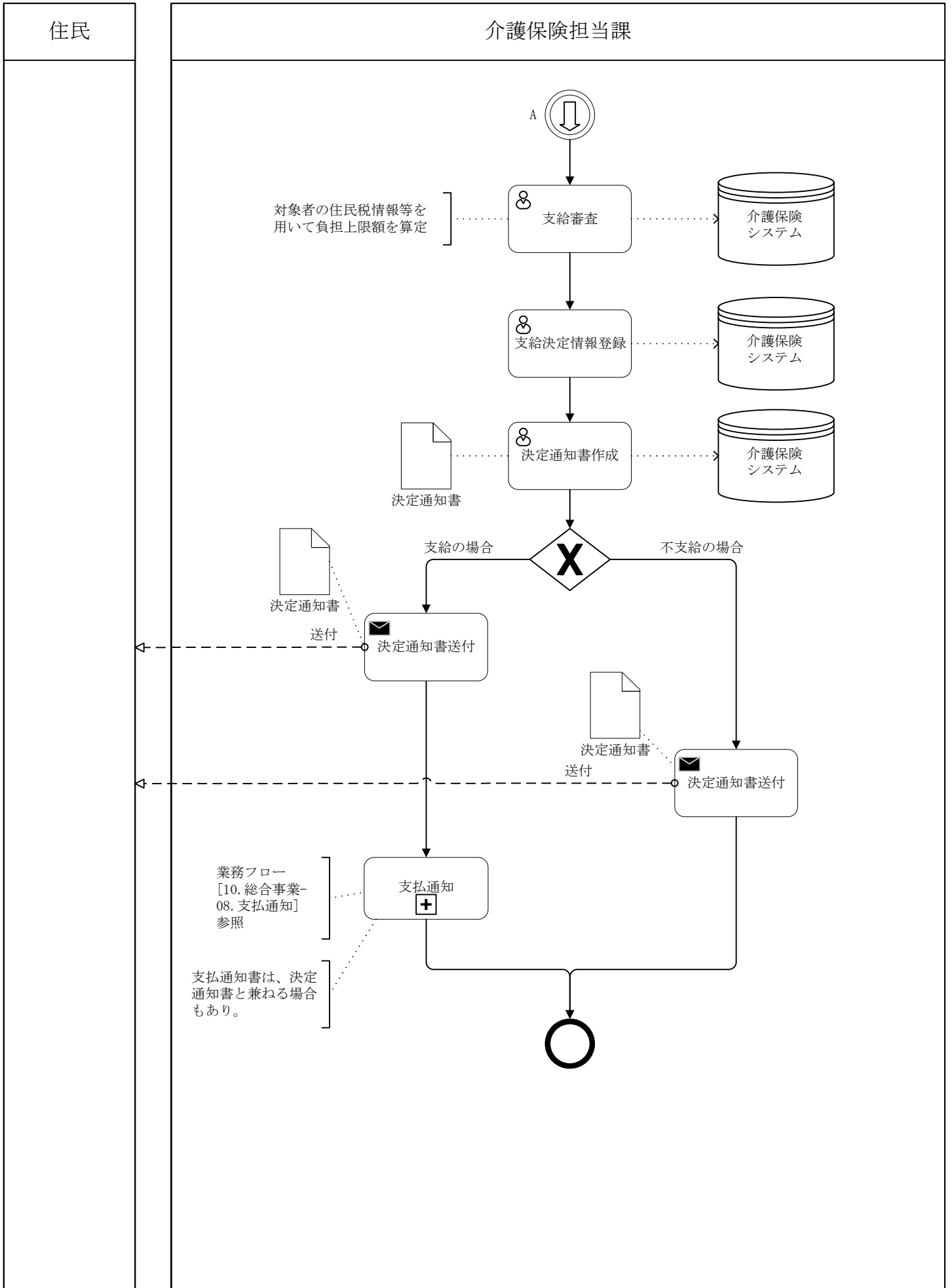

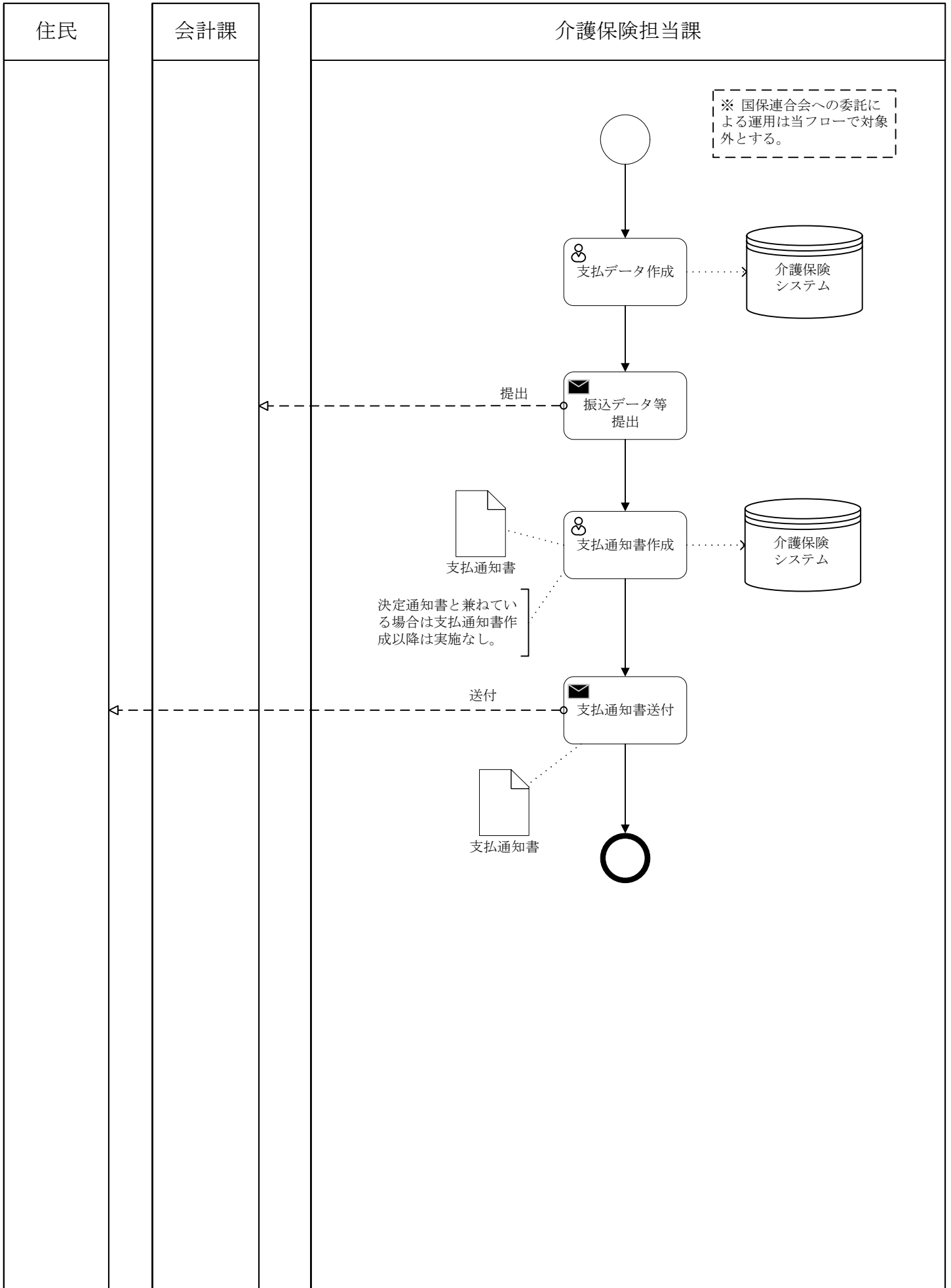

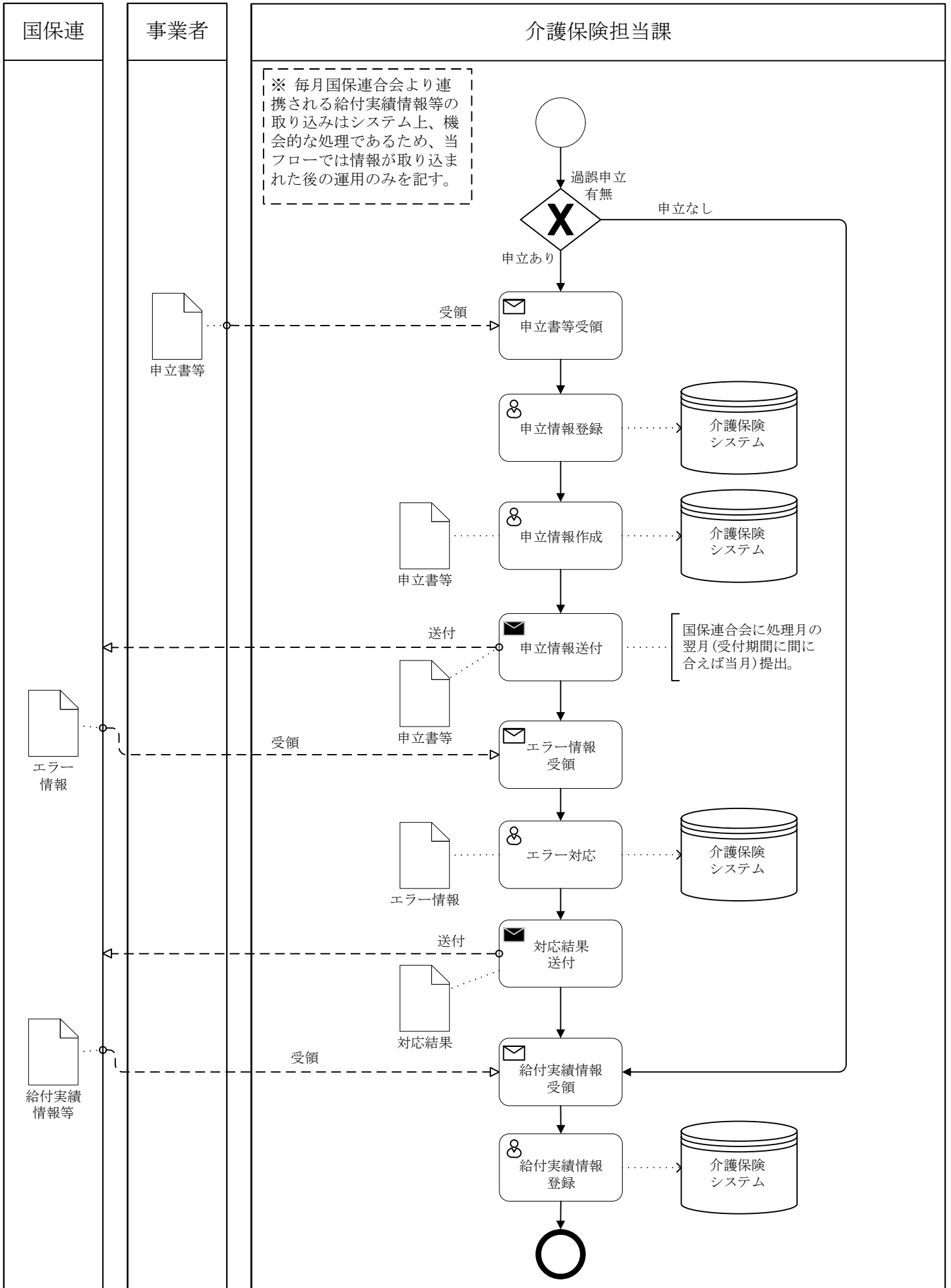

区分	1 介護保険	大分類	10 総合事業	小分類	10 高額医療合算介護予防サービス費相当事業（交付申請）
----	--------	-----	---------	-----	------------------------------

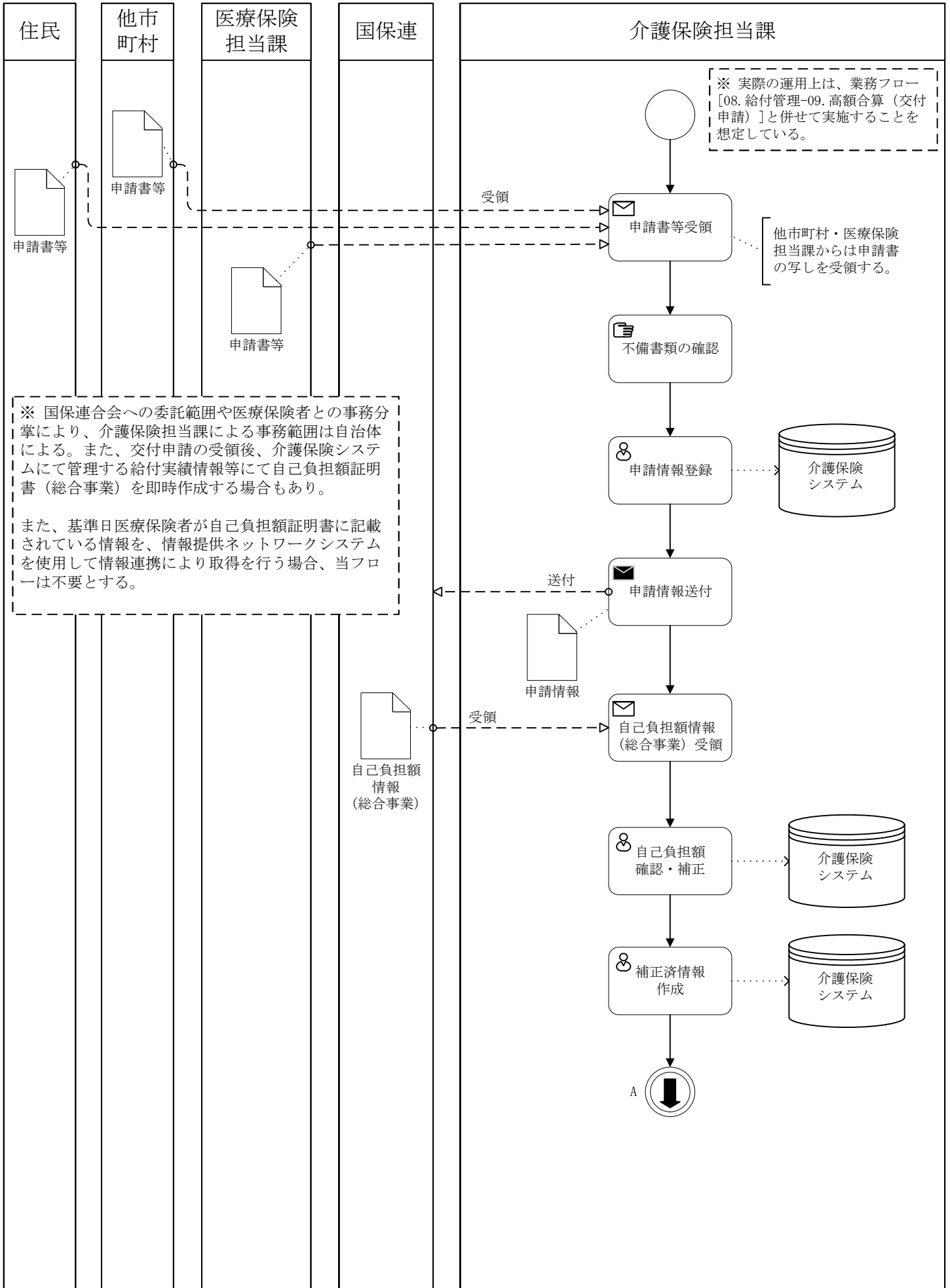

区分	1 介護保険	大分類	10 総合事業	小分類	10 高額医療合算介護予防サービス費相当事業（交付申請）
----	--------	-----	---------	-----	------------------------------

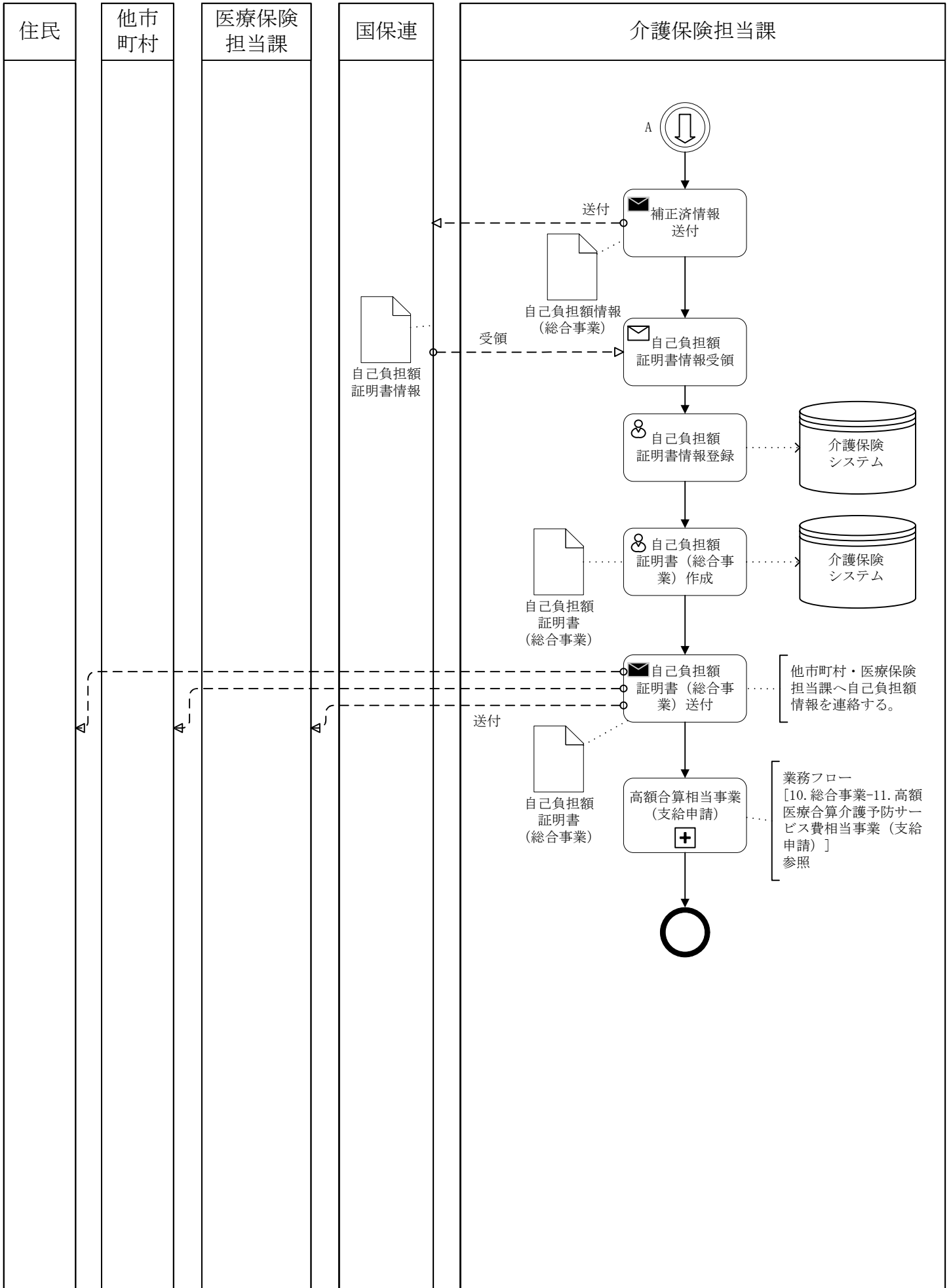

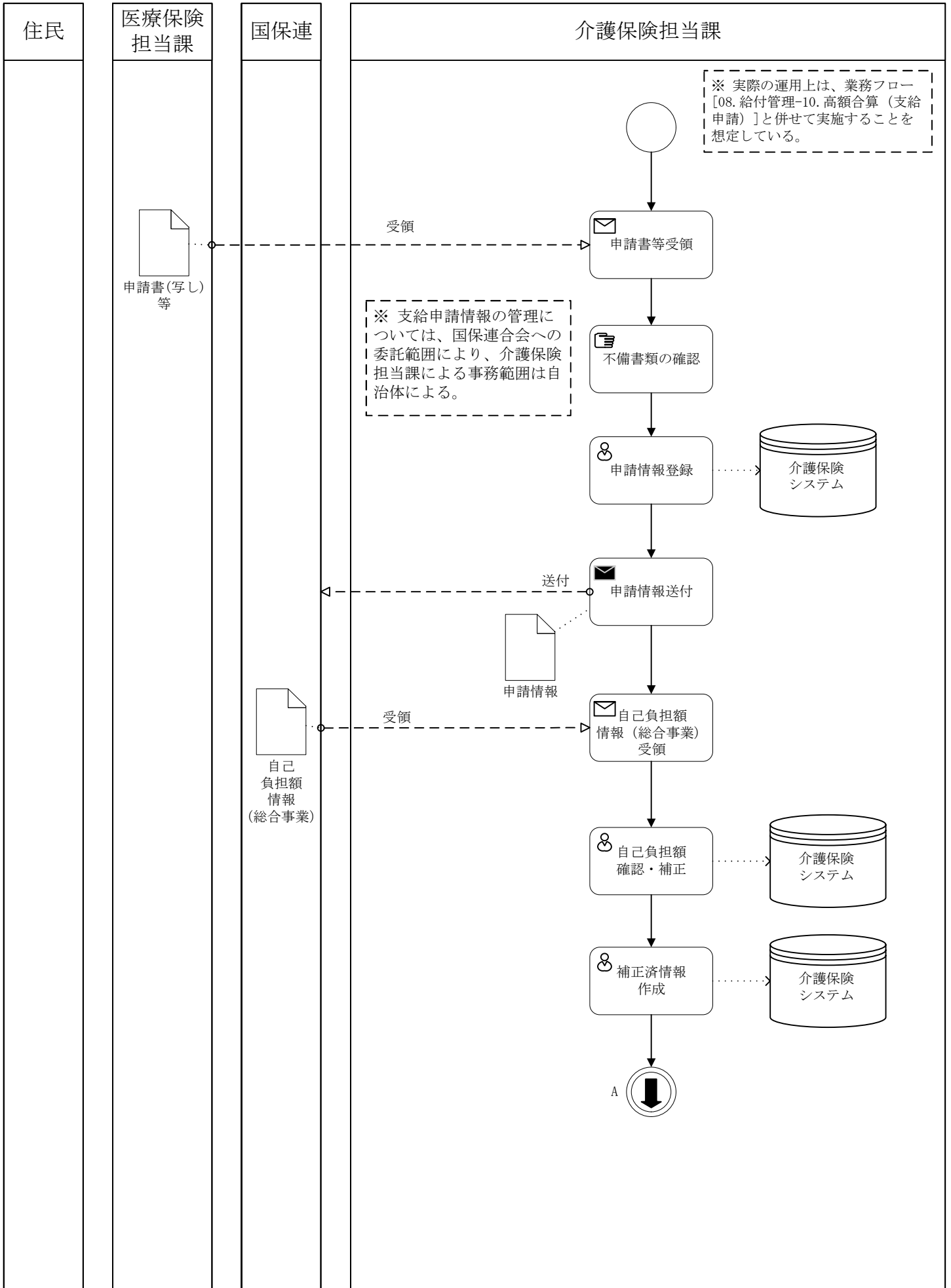

区分	1 介護保険	大分類	10 総合事業	小分類	11 高額医療合算介護予防サービス費相当事業（支給申請）
----	--------	-----	---------	-----	------------------------------

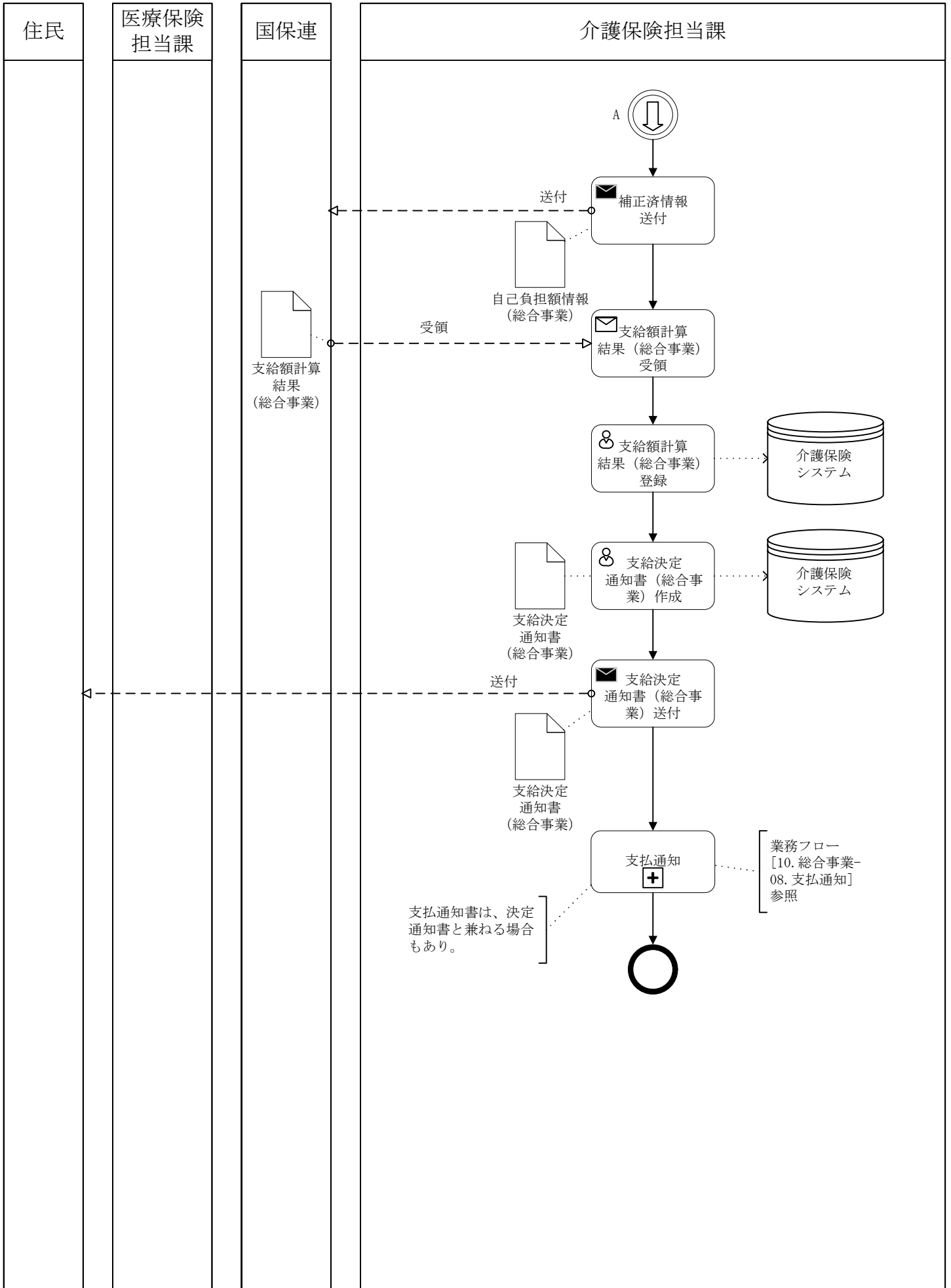

住民

